

# SOCT Technical Inspection

**REVO HR**

**REVO FC**

**130**

REVO FC

**REVO nx 130**

REVO nx

**REVO 80**

REVO 60

**SOCT Copernicus REVO**

Only for the official Optopol service

# Contents

<b>1. CUSTOMER INTERVIEW.....</b>	<b>5</b>
<b>2. EVALUATION OF THE DEVICE ITSELF, VERIFICATION OF THE QUALITY OF EXAMINATIONS RECENT / DIFFERENCE BETWEEN THE RIGHT / LEFT EYE.....</b>	<b>5</b>
<b>3. DISINFECTION OF THE FOREHEAD SUPPORT AND CHIN REST .....</b>	<b>11</b>
<b>4. CHECK SOCT APPLICATION VERSION AND FIRMWARE VERSION ....</b>	<b>11</b>
<b>5. PRELIMINARY CHECK OF THE DEVICE WITH THE APPLICATIONSCANTEST _2.....</b>	<b>11</b>
5.1. Visual control task .....	12
5.2. Params Verification task .....	12
5.3. Device status task.....	13
5.4. Line sensor task.....	14
5.5. Move test task .....	15
5.6. Cgate Encoder task.....	18
5.7. Cgate Stability task .....	19
5.8. Galvo SLED task .....	20
5.9. NDF repeatability task .....	21
5.10. FC Cleaness task.....	22
5.11. Report task.....	23
<b>6. CLEANING OF OPTICS.....</b>	<b>24</b>
6.1. Cleaning the front lens .....	24
6.2. Cleaning the CCD sensor .....	31
6.3. Cleaning of scanner mirrors .....	35

6.4.	Blackspot check .....	36
<b>7.</b>	<b>CHECKING THE POSITION OF THE SCANNING CROSS WITH RESPECT TO INTERNAL FIXATION.....</b>	<b>40</b>
<b>8.</b>	<b>CHECK POSITION OF PREVIEW CAMERAS.....</b>	<b>41</b>
8.1.	Single lens (convex) lens.....	41
8.2.	Three lens lens (concave) .....	43
8.3.	Lens on 155xxx; 156xxx devices .....	45
<b>9.</b>	<b>VERIFICATION / POLARIZATION CORRECTOR.....</b>	<b>48</b>
<b>10.</b>	<b>VERIFICATION / POWER EQUALIZER.....</b>	<b>55</b>
<b>11.</b>	<b>VERIFICATION/SPECTRUM HEIGHT EQUALIZER.....</b>	<b>61</b>
<b>12.</b>	<b>CHECK THE CHIN BOLT TO SEE IF IT IS TIGHTENED (BEHIND THE FRONT CAP) IF THE DEVICE HAS AN ALUMINUM CHIN .....</b>	<b>65</b>
<b>13.</b>	<b>CHECK OF HEAT SINK TIGHTENING - APPLIES TO ONLY155XXX AND 156XXX SERIES DEVICES .....</b>	<b>66</b>
<b>14.</b>	<b>CHECKING THE ALIGNMENT OF THE 19XXXX SCANNER BUNDLES AND CORRECTING IF NECESSARY.....</b>	<b>67</b>
<b>15.</b>	<b>CALIBRATION OF BIOMETRICS AND TOPOGRAPHY MODULES ( IF APPLICABLE ) .....</b>	<b>68</b>
<b>16.</b>	<b>FINAL DEVICE CHECK - TASK FQC SCANTEST_2. 68</b>	
16.1.	Visual control task.....	69
16.2.	Params Verification task.....	69
16.3.	Device status task .....	70
16.4.	Line sensor task .....	71
16.5.	Move test task.....	73
16.6.	Cgate Encoder task .....	75

<b>16.7.</b>	<b>Cgate Stability task.....</b>	<b>76</b>
<b>16.8.</b>	<b>Galvo SLED task.....</b>	<b>77</b>
<b>16.9.</b>	<b>NDF repeatability task.....</b>	<b>78</b>
<b>16.10.</b>	<b>FC Cleanness task.....</b>	<b>79</b>
<b>16.11.</b>	<b>Report task.....</b>	<b>80</b>
<b>17.</b>	<b>FINAL TEST QUALITY CHECK.....</b>	<b>80</b>
<b>18.</b>	<b>LIST OF REQUIRED TOOLS FOR TECHNICAL REVIEW.....</b>	<b>81</b>

The following instructions are procedures for the periodic inspection of the SOCT Revo. All of the included steps must be fulfilled at the customer visit to ensure that the device is fully operational. Applies to generations:

- 155xxx
- 156xxx
- 190xxx
- 1905xxx
- 191xxx
- 192xxx
- 193xxx
- 194xxx

## 1. Interview with the customer

The first step should include a preliminary diagnosis of the situation of the device itself. It is advisable to talk to the customer to find out whether he noticed any disturbing behavior of the device or application. This will allow to pay special attention to specific functions of the device to exclude potential problems.

## 2. Verification of device condition, checking of the quality of recent examinations-difference between the right / left eye

The second step should be a visual check of the device itself. In this step it is necessary to determine whether the front lens is not damaged, shining a flashlight at an angle ( in some cases it will be necessary to pre-clean the front lens to make an assessment ). Any kind of damage should be immediately reported to the customer, And in the opinion of the service technician may result in a negative technical inspection.

Next, we check the fit of the housings, the condition of the exterior fixation, and the conformity of the nameplates on the back of the device.

Any discrepancies should be addressed directly to the customer on site, and it remains in the judgment of the service technician whether to proceed.

In the next step, we start the computer ( if necessary ), launch the SOCT application, log in with the user login credentials, and at the filter tab, set the patient list in terms of recent examinations. We check the average quality of recent examinations, taking into account the patient's age, possible medical conditions, etc.

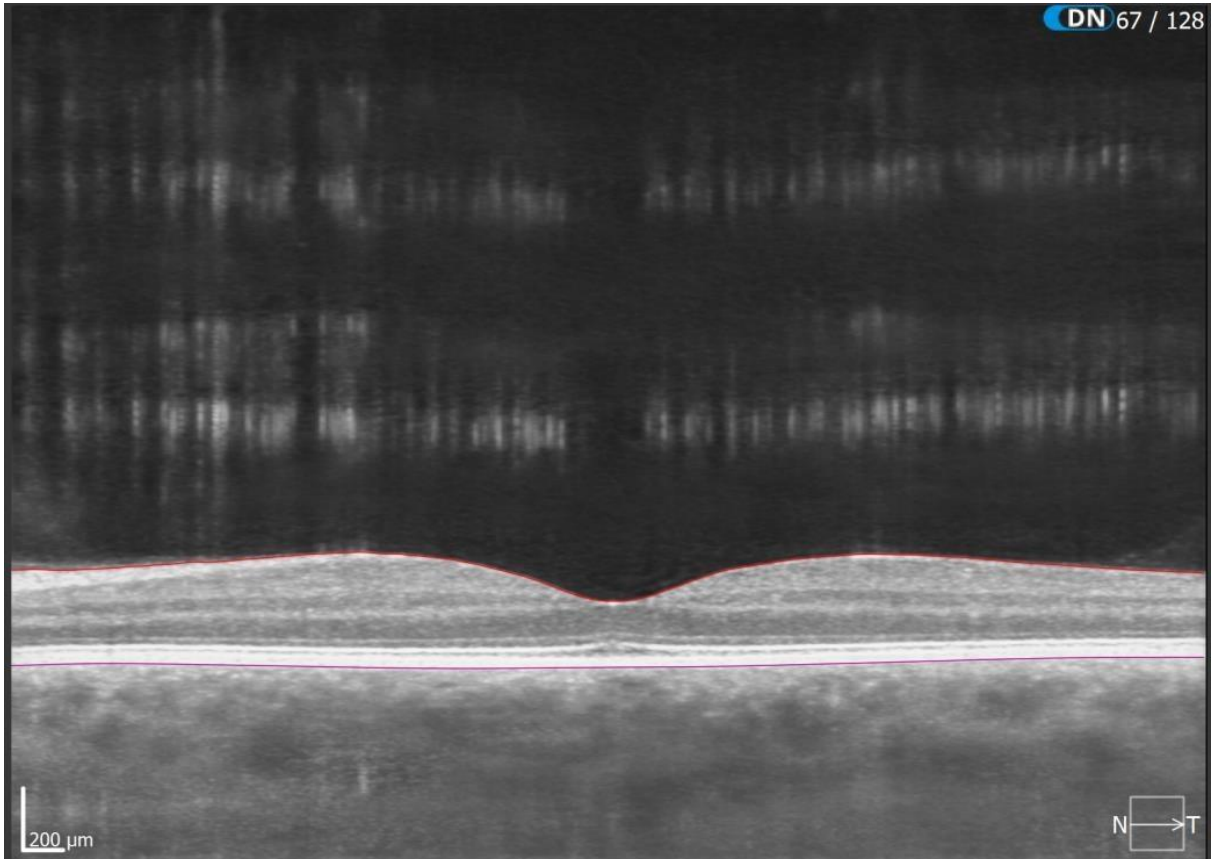

Too high power and spectrum

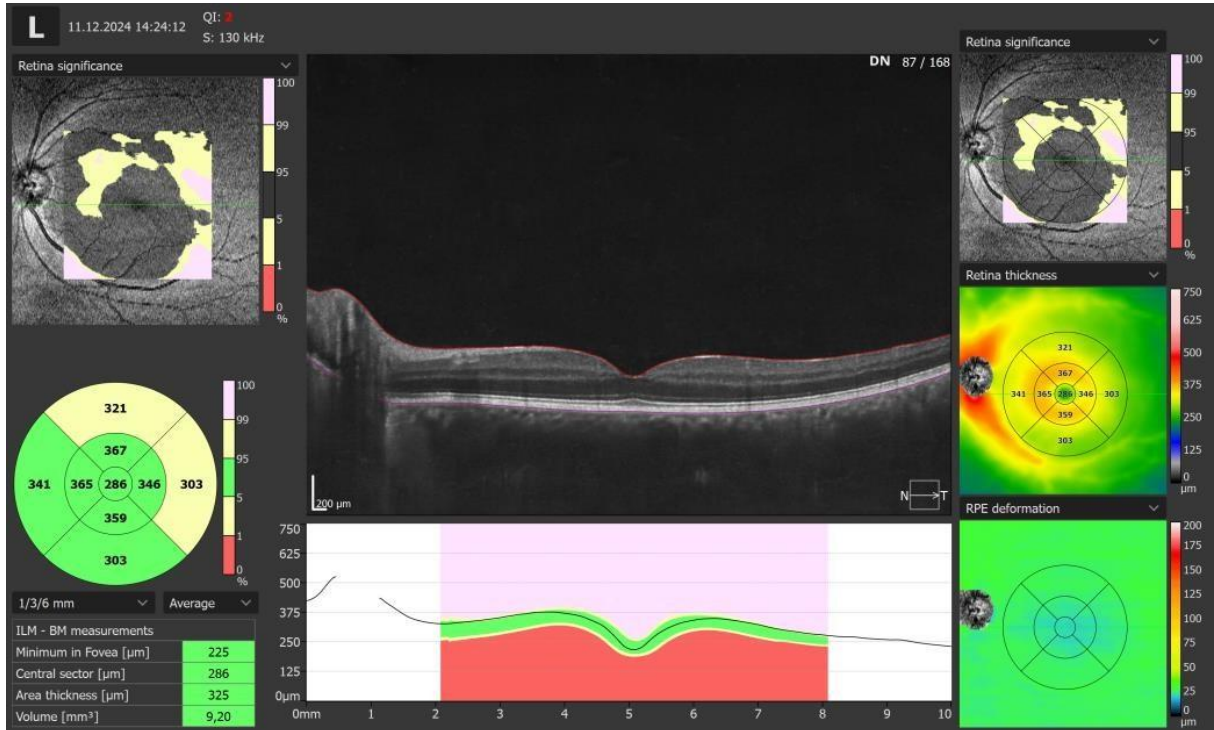

Low power, spectrum and improper polarization

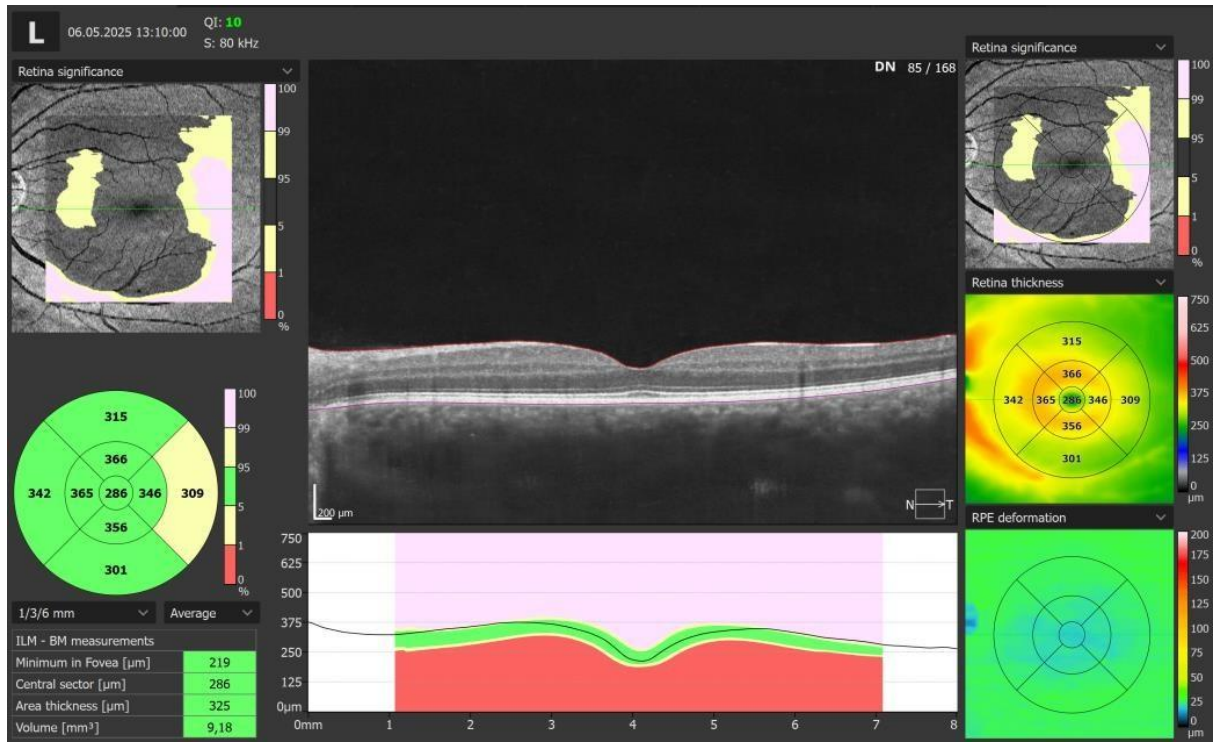

Testing the correct quality

In the case of funduscam devices, we assess whether there are any disturbing artifacts in the images indicating a problem with the blackspot, holemirror, scratched lens or dirty optics.

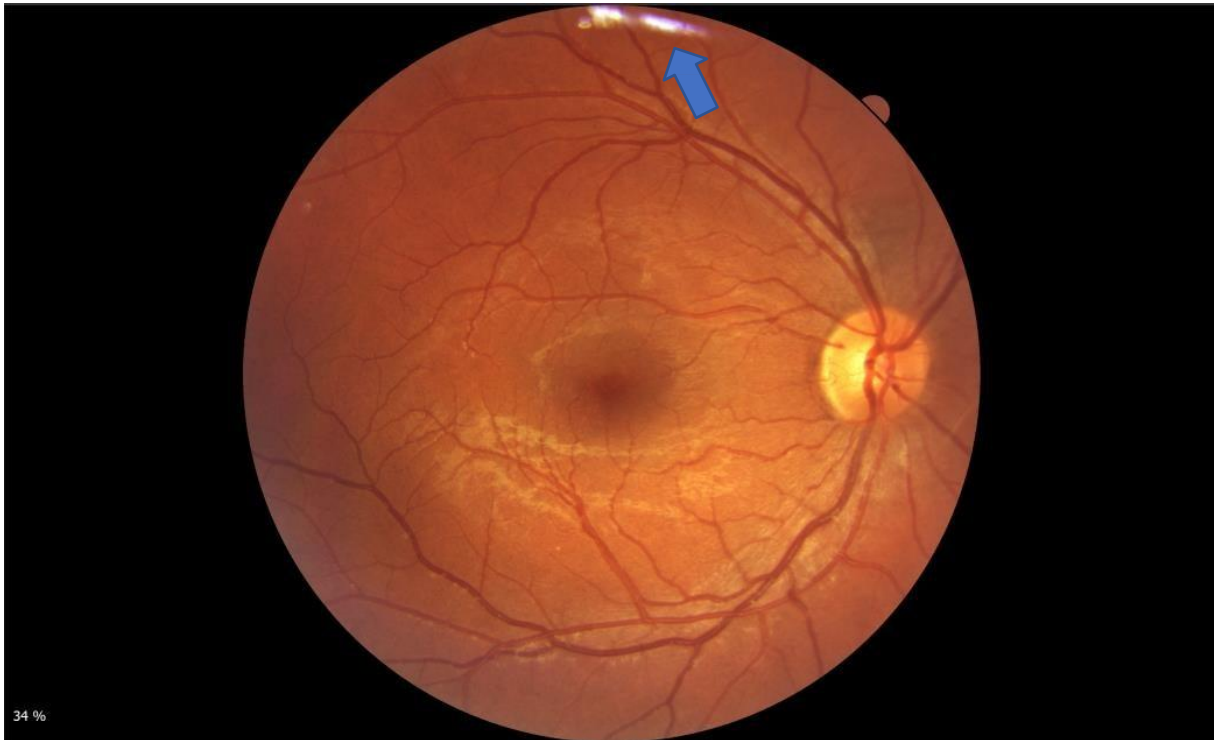

Dirty front lens

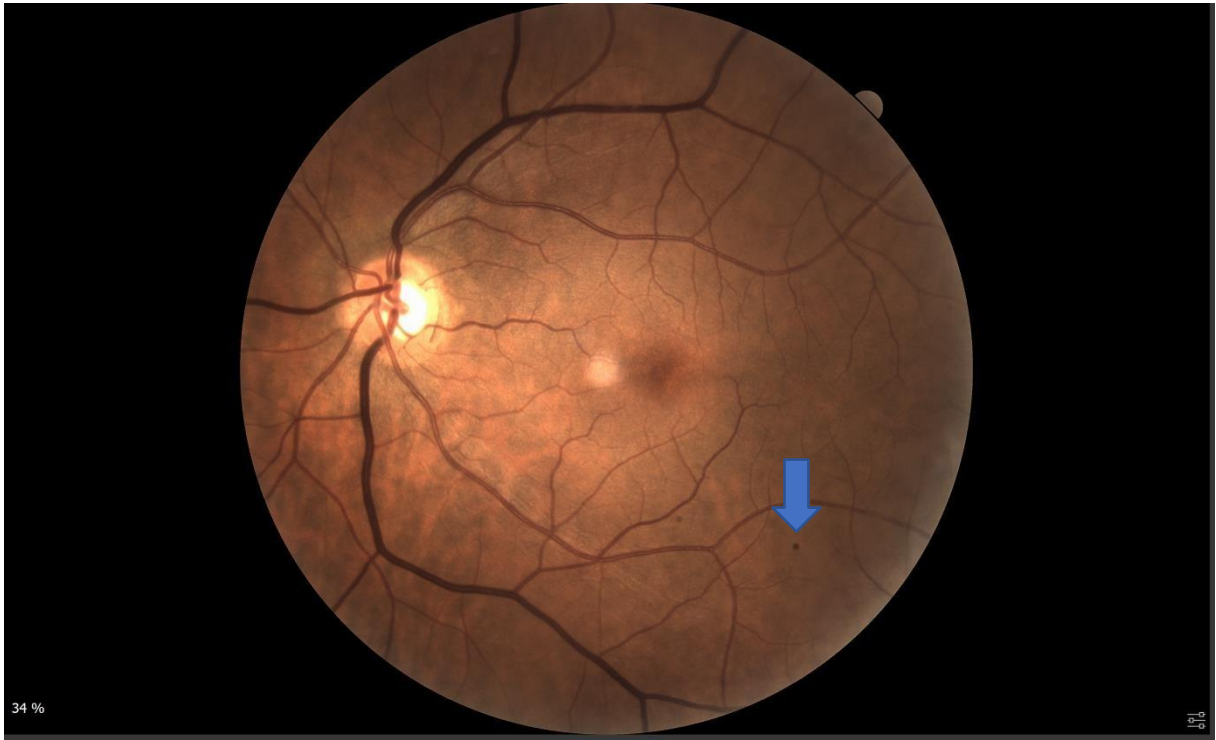

Dirt on the CCD sensor

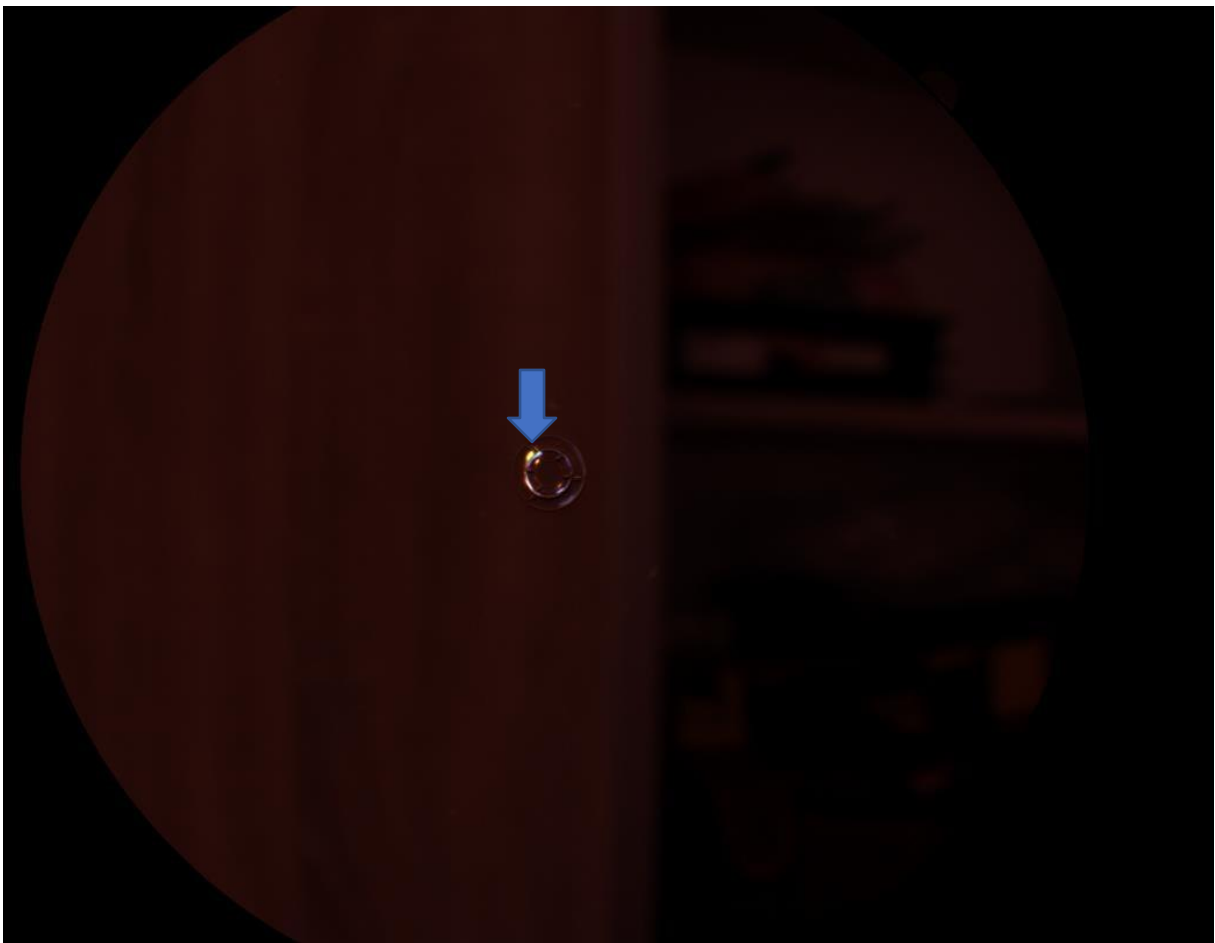
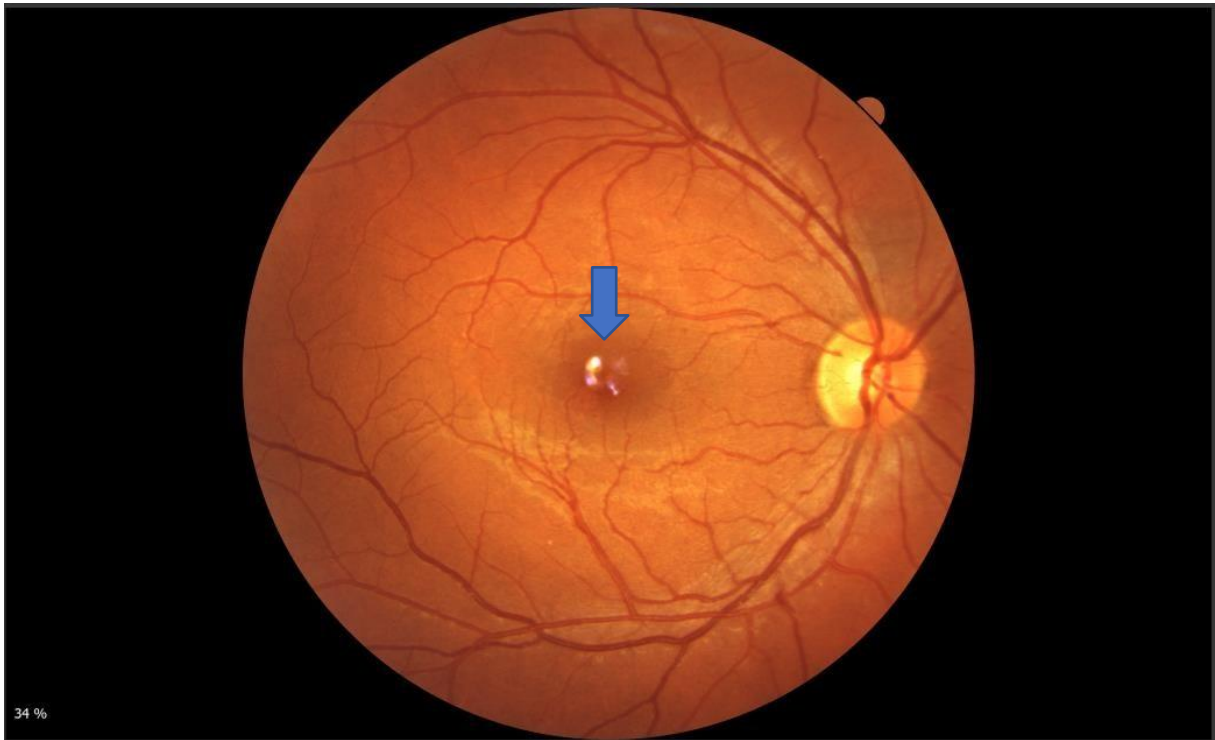

Apparent problem with blackspot

### 3. Disinfection of the forehead support and chin rest

Since some of the following activities will require contact with the back of the forehead and the chin, it is advisable to preemptively disinfect the chin with an agent indicated for this purpose. It can be the client's own, or the client's if there is a possibility.

### 4. Check SOCT application version and firmware version

In this step, it is recommended to update the SOCT application and firmware to the latest version, if possible.

### 5. Initial check of the device using the Scantest\_2 application

**NOTE:** Remember to always use the latest version of Skantest\_2

In this step, use the "Initial inspection" mode.

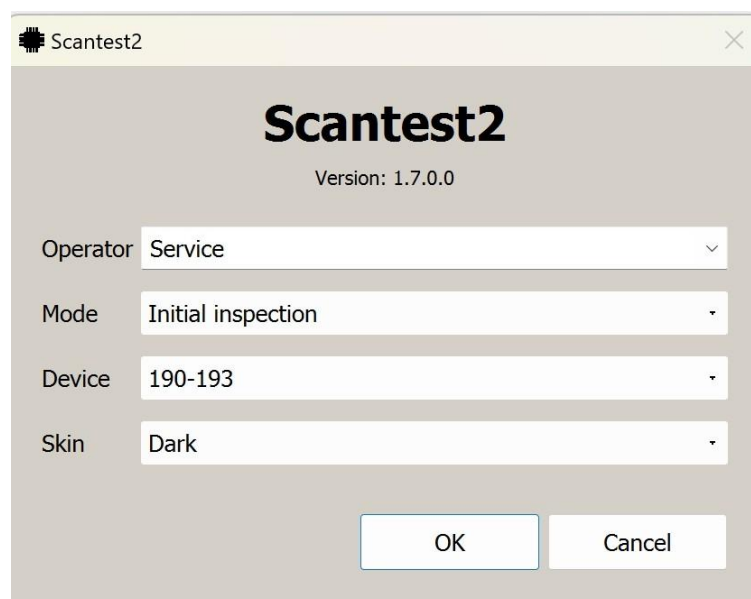

The tasks that are there will allow to assess the condition of the device in terms of power, and the overall technical condition of the SOCT.

At the very end, generate a report which is a confirmation of the initial state of the device.

This will provide a comparison with the final device check report.

## 5.1. Visual control task

Required tools: none

Supported devices: 155, 156, 190, 191, 192, 193, 194

Task to conduct visual inspection of the device during final acceptance.



After starting the task with the Start button, 8 points are displayed regarding the external appearance of the device. The operator should read each point, assess the condition of the connected device according to the point and mark PASS or FAIL depending on whether the requirement is met or not. Once all PASS/FAIL are marked, the task ends automatically.

## 5.2. Params Verification task

Required tools: none

Supported devices: 190, 191, 192, 193, 194

The task is used to verify the calibration parameters of the device.

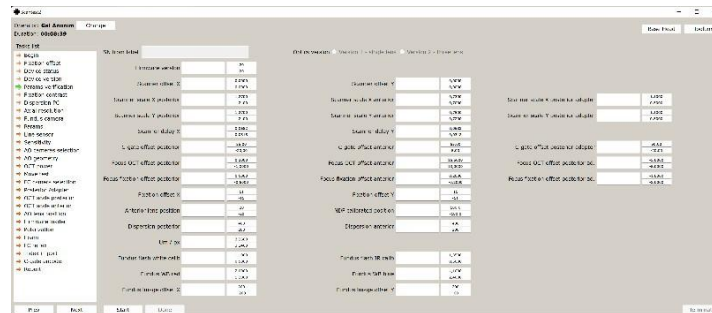

After starting the task with the Start button, some configuration parameters are read and their correctness is checked to see if they are within the intended range. In addition, in order to verify the correctness of the serial number with the label on the device and the correctness of the selected optics version of the device, the operator is asked to provide this information. The task ends by pressing the Done button, if all checked parameters are within the range and the operator has entered a compatible serial number and optics version of the device then the task has the status PASS, otherwise FAIL. To prevent the serial number and optics version from being read from the labels at the top of the main window, they are hidden for the duration of this task. The list of displayed parameters varies depending on the type of connected device, e.g. for 191/192 devices the parameters for the camera fundus are not displayed.

## 5.3. Device status task

Required tools: none

Supported devices: 190, 191, 192, 193, 194

The task is used to read the status of the device to diagnose potential damage.

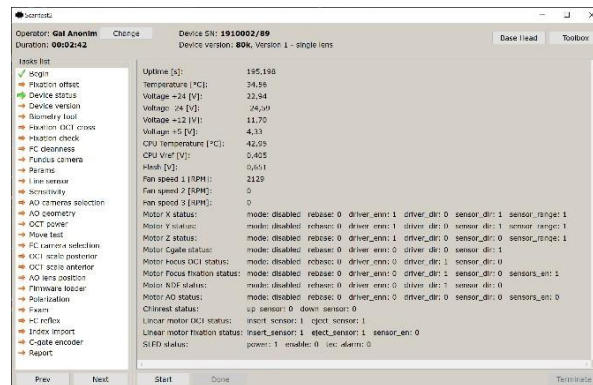

This task does not allow modification of any parameter of the device, it is only used to read the current status. After starting the task, a number of parameters are displayed which are then refreshed cyclically several times per second. The parameters displayed are:

- Uptime - the time in seconds that has elapsed since the device started up
- Temperature - the temperature of the device as measured by a sensor mounted on the CPU board
- Voltage +24 - measured value of supply voltage +24V
- Voltage -24 - measured value of supply voltage -24V
- Voltage +12 - measured value of 12V supply voltage
- Voltage +5 - measured value of supply voltage 5V
- CPU Temperature - temperature of the microcontroller
- CPU Vref - the value of the microcontroller reference voltage
- Flash - state of charge of Flash capacitors
- Fan speed 1 - the number of revolutions per minute of the fan connected to connector 1
- Fan speed 2 - the number of revolutions per minute of the fan connected to connector 2
- Fan speed 3 - the number of revolutions per minute of the fan connected to connector 3
- Motor X status - operating status of motor X
  - mode - mode of operation - base / move / disabled
  - rebase - if 1 it means that the engine probably lost the steps and redetermined the value of zero when passing through the baseline
  - driver\_enn - state of the ENN line of the stepper motor driver
  - driver\_dir - state of the DIR line of the stepper motor driver
  - sensor\_dir - state of baseline determining zero position
  - sensor\_range - state of baseline limiting range of motion

- Motor Y status - operating status of motor Y, description of fields as above.
- Motor Z status - operating status of motor Z, description of fields as above.
- Motor Cgate status - operating status of the motor Cgate, description of fields as above.
- Motor Focus OCT status - operating status of motor focus OCT, description of fields as above.
- Motor Focus fixation status - operation status of the motor focus fixation, description of the fields as above.
- Motor NDF status - operating status of the motor NDF, description of fields as above.
- Motor AO status - operation status of anterior lens motor, description of fields as above.
- Chinrest status - the status of the chin basalts, upper and lower, respectively
- Linear motor OCT status - baseline status of the linear motor OCT
- Linear motor fixation status - baseline fixation motor baseline status and baseline fixation engagement status
- SLED status - status of the SLED LED
  - power - if 1 then SLED power is on
  - enable - if 1 then SLED diode is enabled
  - tec\_alarm - if 1 then the diode reports the TEC module alarm

The condition of some baseplates, especially linear motors and the AO motor, may not be correct because they are powered only when the motor in question is moving.

## 5.4. Line sensor task

Required tools: Power meter, power meter adapter Supported devices:

155, 156, 190, 191, 192, 193, 194

This task allows you to display the spectrum of the OCT signal.

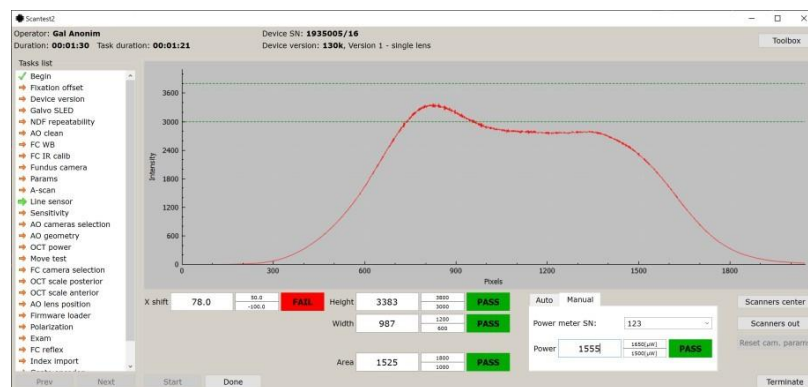

After starting the task with the Start button, the spectrum of the OCT signal read from the spectrometer's camera is displayed on the graph, in addition, the interval in which the spectrum should measure is displayed. In addition, the following parameters are measured:

- X shift - shift of the spectrum in the horizontal axis of the camera
- Y shift - shift of the spectrum in the vertical axis of the camera (only for devices 155 with Aviiva camera)
- Z rotation - twisting of the spectrum in the Z axis of the camera (only for devices 155 with Aviiva camera)

- Height - the height of the spectrum
- Width - half-width of the spectrum
- Area - area under the spectrum graph

Additional functions in this task here:

- Power measurement on the lens in automatic mode (Power Meter connection required) or in manual mode
- Save to file option in the context menu on the chart - allows you to save the spectrum to a file
- Log switch in the context menu on the graph - allows you to display the spectrum on a logarithmic scale
- Idx switch in the context menu on the chart - allows you to display the spectrum after reindexing
- Scanners center button - allows you to center the position of galvo scanners for power measurement, then the height of the spectrum is not counted
- Scanners out button - setting the position of galvo scanners out of the lens for correct measurement of spectrum height
- Reset cam. params button - allows you to reset the camera settings to default values (option available only for Aviiva cameras on 155 devices)

The task ends with the Done button and no parameters are saved in the device configuration after completion.

Name of the task in the XML file: line\_sensor

Parameters to be defined in the XML file:

- x\_shift - permissible range of the X shift parameter
- y\_shift - the permissible range of the Y shift parameter
- z\_rotation - the permissible range of the Z rotation parameter
- height - the permissible range of the Height parameter
- width - permissible range of Width parameter
- area - permissible range of the Area parameter
- power - permissible range of the power parameter
- meter\_sn - serial number of the power meter
- hide\_power\_measure - when this parameter is added, the power measurement function is hidden

## 5.5. Move test task

Required tools: none

Supported devices: 155, 156, 190, 191, 192, 193, 194 The task is used to test various modules of the device.

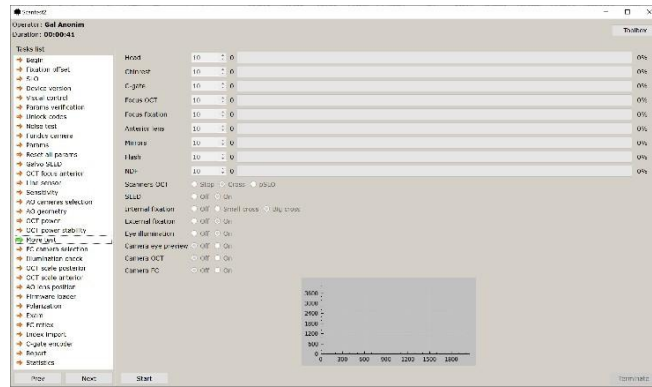

You can perform the test of the following modules:

- Head - passage of the device head in X, Y and Z axes
- Chinrest - chin ride up - down
- Spectrometer - drive of spectrometer motors (only 155 devices with Aviiva camera)
- Cgate - engine run in the reference track
- Focus OCT - a run of the focus engine in the OCT circuit
- Focus fixation - the passage of the focus motor in the fixation track
- Anterior lens - passage of anterior lens motor (only in 19x devices)
- Mirrors - slide OCT and fixation mirrors in and out (only on 190, 193 and 194)
- Flash - triggers flash (only on 190, 193 and 194 devices)
- NDF - passage of the NDF filter motor (only on 19x devices)

In addition, it is possible to run additional modules when performing a motion test of the above modules.

- galvo OCT scanners - if enabled, they can operate in two modes - Cross (quick preview mode) and pSLO (pSLO preview mode, available only on 155, 156, 190-194 devices)
- SLED - SLED LED illumination
- Internal fixation - display of internal fixation
- External fixation - external fixation illumination
- Eye illumination
- Camera eye preview - cameras for eye preview, camera image is displayed at the bottom of the window
- Camera OCT - OCT camera, the read spectrum from the camera is displayed in the graph at the bottom of the window
- Camera FC - FC camera, the camera image is displayed at the bottom of the window (devices 190, 193 and 194 only)

The number of repetitions of movement of each module can be defined in the XML file, by default each value is set to zero which means that the module will not be tested.

Once all the runs are completed, the task ends automatically. This task does not modify any parameters in the device configuration.

Name of the task in the XML file: `move_test`

Parameters to be defined in the XML file:

- `repeat_head` - number of repetitions of the head module passage
- `repeat_chinrest` - number of repetitions of the Chinrest module ride
- `repeat_spectrometer` - number of repetitions of the Spectrometer module pass
- `repeat_cgate` - number of repetitions of the Cgate module passage
- `repeat_focus_oct` - number of repetitions of the Focus OCT module passage
- `repeat_focus_fix` - number of repetitions of the Focus fixation module passage
- `repeat_focus_ld` - number of repetitions of the Focus LD module pass
- `repeat_focus_cam` - number of repetitions of the Focus cam module passage
- `repeat_anterior_lens` - number of repetitions of the passage of the Anterior lens module
- `repeat_mirrors` - number of repetitions of OCT mirror insertion/extension and fixation
- `repeat_flash` - number of flash triggers
- `repeat_filter_oct_icg` - number of repetitions of OCT/ICG filter pass
- `repeat_filter_slo` - number of repetitions of SLO filter passes
- `repeat_ndf` - number of repetitions of the NDF filter pass
- `scanners` - galvo scanners mode (0= scanners stopped, 1= cross mode, 2= pSLO mode)
- `sled` - SLED LED on (0= LED off, 1= LED on)
- `fix_int` - internal fixation (0= off, 1= small cross, 2= large cross)
- `fix_ext` - external fixation (0= disabled, 1= enabled)
- `illumination` - eye illumination (0= off, 1= on)
- `camera_ep` - eye view cameras (0= off, 1= on)
- `camera_oct` - OCT camera (0= disabled, 1= enabled)
- `camera_fc` - FC camera (0= disabled, 1= enabled)
- `speed_head_x` - head travel speed in the X axis
- `speed_head_y` - head travel speed in Y axis
- `speed_head_z` - head travel speed in Z axis
- `delay_head` - delay between successive head passes
- `delay_mirrors` - delay between successive insertions/extensions of mirrors
- `delay_flash` - delay between successive flash triggers

## 5.6. Cgate Encoder task

Required tools: none

Supported devices: 190, 191, 192, 193, 194

This task is used to check the operation of the encoder in the reference track on 19x devices. When the Start button is pressed, the reference mirror is moved to the beginning of the travel range and then slowly to the end of the range. During this travel, the task position (green), the position read from the motor steps (red) and the position read in the encoder (blue) are read. All these values are displayed on a graph as a function of the mirror position. In addition, an error graph (magenta color) between the task position and the position read from the encoder is displayed, multiplied by 100 to make minor deviations visible.

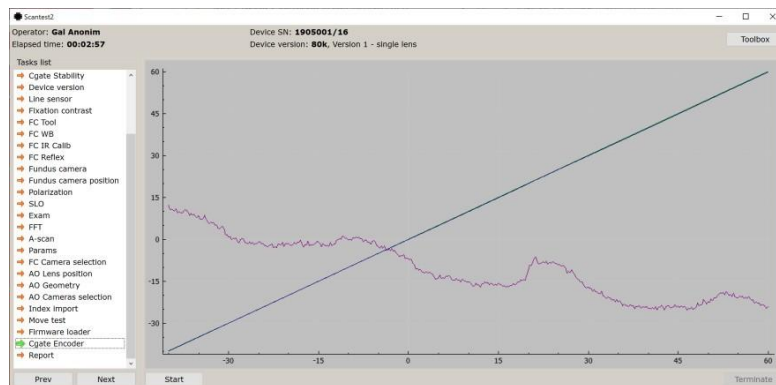

When the mirror reaches the end of the range, the task ends automatically.

## 5.7. Cgate Stability task

Required tools: none

Supported devices: 155, 156, 190, 191, 192, 193, 194

This task is used to check the stability of the reference track as a function of the position of the mirror in the track. When the Start button is pressed, the mirror is moved to the start position (-40 mm) and the spectrum of the signal returning from the reference track is displayed on the first graph. After a while, the movement of the mirror up to the final position (78 mm) is started, and during this movement the signal spectrum is continuously displayed, as well as its height as a function of the position of the mirror on the second graph.

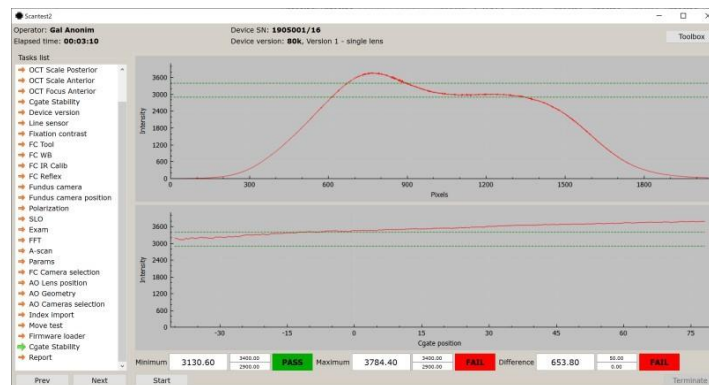

When the mirror reaches the final position, then the task ends automatically. Three parameters are displayed below the graphs, which are checked during the mirror's passage:

- Minimum - minimum spectrum height (value depends on the connected device)
- Maximum - maximum spectrum height (value depends on the connected device)
- Difference - the difference between the maximum and minimum recorded spectrum height (the default acceptable range is 0 to 50)

Name of the task in the XML file: cgate\_stability

Parameters to be defined in the XML file:

- height - acceptable range of spectrum height (minimum and maximum)
- diff - permissible difference between maximum and minimum spectrum height

## 5.8. Galvo SLED task

Required tools: none

Supported devices: 155, 156, 190, 191, 192, 193, 194

The task is long to check that the SLED LED does not turn off in different positions galvo scanners.

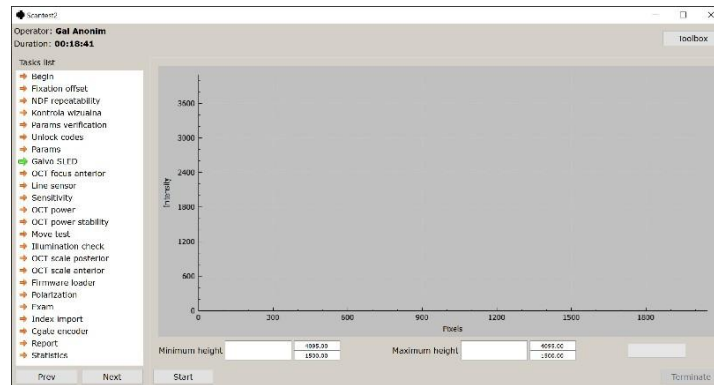

After starting the task with the Start button, the spectrum of the OCT signal is displayed on the graph and the height of this spectrum is measured. The galvo scanners are then moved from one extreme position (default -10V) to the other extreme position (default 10V) with a preset step (default 0.25V). While the galvo scanners are stationary at each position, the spectral height is measured and the parameters recording the minimum and maximum spectral heights are updated accordingly. The progress of the entire task is presented on the progress bar. The task ends automatically when the spectrum height is verified over the entire range. This task does not modify any parameters in the device configuration.

Name of the task in the XML file: galvo\_sled

Parameters to be defined in the XML file:

- height - permissible range of spectrum height
- range - range of galvo scanner movement in which the measurement is made
- step - the step with which the measurement is performed
- delay - the time in milliseconds that is waited after each adjustment of the scanners position

## 5.9. NDF repeatability task

Required tools: none

Supported devices: 190, 191, 192, 193, 194

The task is used to check whether the NDF filter sets repetitively in the set position.

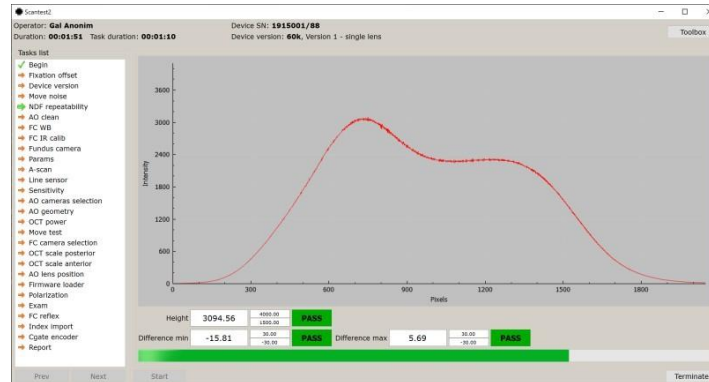

After starting the job with the Start button, the NDF filter is set to the base (calibrated) position. The reference spectrum height that is expected with such a filter setting is read. Then the specified number of cycles (default 10) of setting the filter to one extreme position and the other extreme position and returning to the base position is performed. After each return to the base position, the spectrum height is read and the deviation from the reference height is counted. The maximum deviation to plus and minus is displayed in the corresponding windows. The task ends automatically after the specified number of cycles.

Name of task in XML file: ndf\_repeat

Parameters to be defined in XML file:

- diff - permissible deviation of spectrum height from the reference value
- count - number of test cycles

## 5.10. FC Cleanness task

Tools required:None Supported

devices:190, 193, 194

This task is used to check the cleanliness of the optics in the video path of the camera fundus in devices 190, 193 and 194. It is possible to start IR preview and take a picture in four configurations:

- with both mirrors (fixation and OCT) extended and Anterior lens extended
- With both mirrors (fixation and OCT) extended and the Anterior lens retracted
- with the fixation mirror retracted and the OCT extended and the Anterior lens extended
- With OCT mirror retracted and fixation extended and Anterior lens extended

In each configuration, the operator evaluates the cleanliness of the image, if any impurities are visible then remove them and take the picture again.

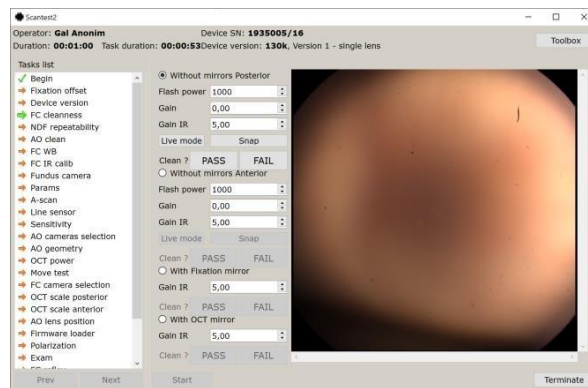

For the first two configurations (without both mirrors), it is possible to set the following parameters

- flash power
- camera enhancement for the photo
- camera gain for IR

In these two configurations, you can display both IR preview and take a photo. For the latter two configurations, on the other hand, it is only possible to start IR preview and so only camera gain for IR mode is available in the list of parameters to modify.

When all four PASS/FAIL buttons are selected, the task ends automatically. This task does not modify any parameters in the device configuration.

## 5.11. Report task

Required tools: none

Supported devices: 155, 156, 190, 191, 192, 193, 194

The task is used to generate two PDF reports of completed tasks. One full for digital documentation, the other without some previews for printing with the annotation \*\_print.pdf

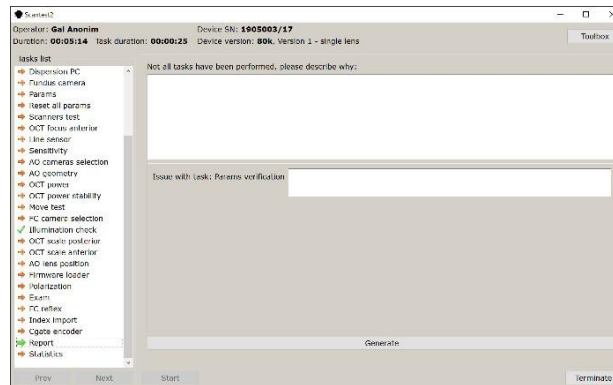

This task should be at the end of the task list. After starting a task with the Start button, a window is displayed with an opportunity to enter a comment. If at least one task from the task list has been skipped, then a comment is mandatory. In addition, if there are tasks with FAIL status then below the comment box a list of FAILs is displayed with the possibility to enter a comment for each of them. After entering comments, you can generate a PDF report by clicking on the Generate button. After the report is generated, a link to the generated file is displayed. This task does not modify any parameters in the device's configuration memory.

## 6. Cleaning the optics

Tools required: KG1, cleaning papers, cleaning stick Supported devices: 155, 156, 190, 191, 192, 193, 194

A pre-check task may show the need to clean the optics listed below.

In addition, it is worth checking recently taken photos ( if applicable ) for repeating artifacts.

**NOTE:** Dark artifacts will most likely be on the CCD sensor, and bright artifacts will be on the front lens. In some cases, this rule may have an exception if the zabeudz will be on the hole mirror.

**NOTE:** For devices with a funduscamera module, blackspot extinction should be evaluated.  
**Especially devices below the serial number:**

- 1906022
- 1935201

### 6.1. Cleaning the front lens

Required tools: KG1, cleaning papers, cleaning stick

Supported devices:190, 191, 192, 193, 194

1. First, you can clean the lens from the front, and then see if the artifacts are gone.
2. Use disposable paper wipes and fast evaporating cleaning solution or isopropanol. Start at the top of the lens, then move the wipe along both sides until you reach the bottom of the lens.

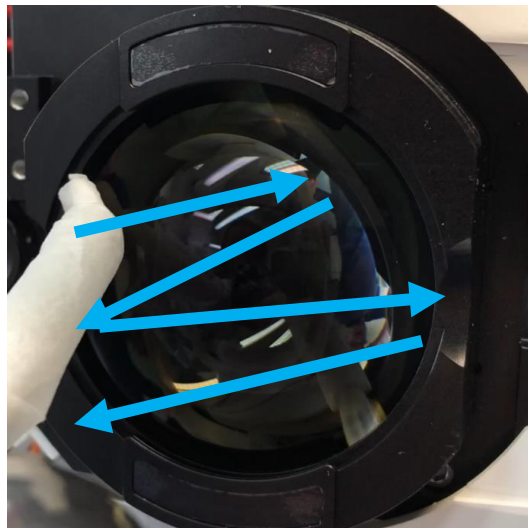

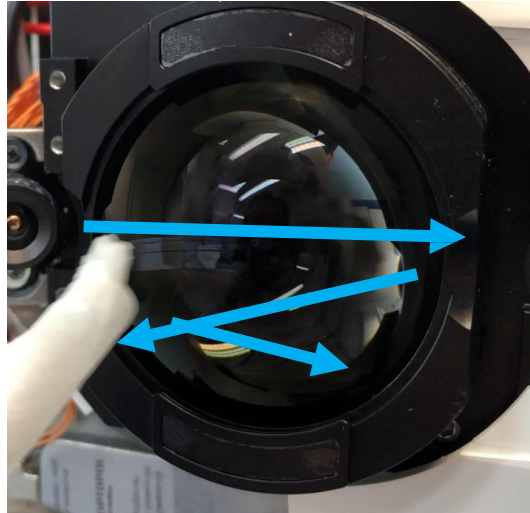

3. To clean the inside of the lens, there are two ways to do it: access the lens side or remove the lens completely.
4. Disconnect the left preview camera and remove the metal cover attached with 1.5 Allen screws.
5. Use a paper cloth and isopropanol, then clean the lens with rotary motions and finally wipe off the dust. If there is a lot of dust on the lens, use compressed air before using the paper cloth.

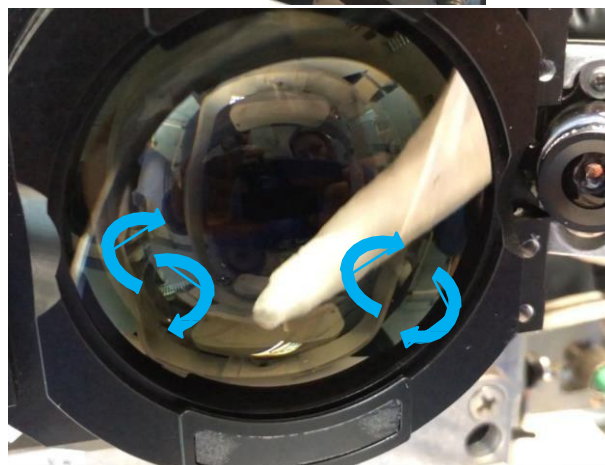
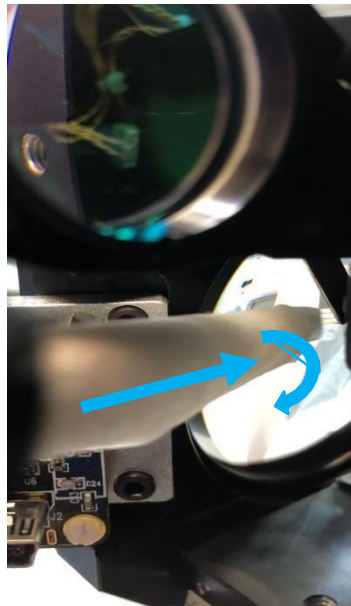

6. For easy access to the inside of the lens for cleaning, remove the lens module.
7. To do this, unscrew the 4 mounting screws and gently remove. Be careful with the connection cables of the IR LED.
8. Open the SOCT head.
9. Disconnect the USB cables from the preview cameras.

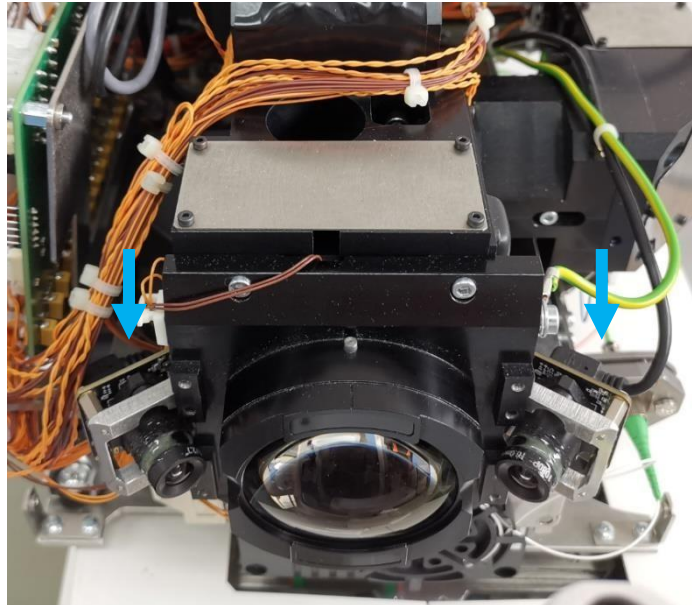

10. Now you have access to the electronics. Disconnect the connection cable - J12 and J12\_2 plugs from the processor board.

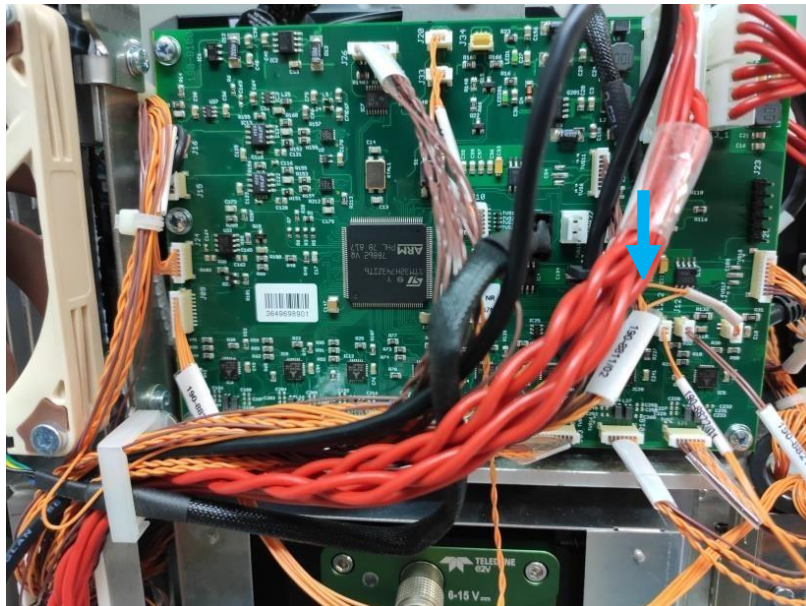

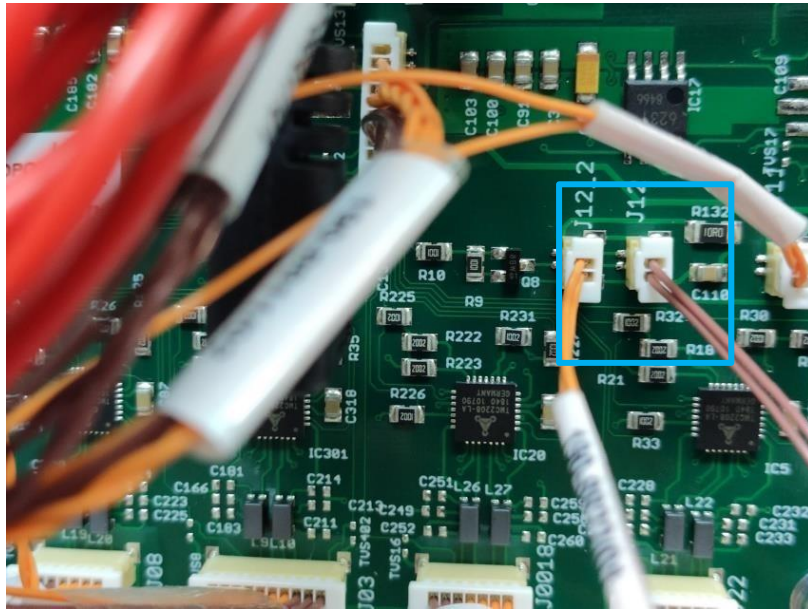

11. Remove the 4 screws holding the lens - use a 2.5 mm Allen wrench. Hold the lens with your hand while removing the last screw.

**NOTE:** It is recommended to unscrew the screws on the lens salts, then put the lens hood on the lens and unscrew the two screws on top.

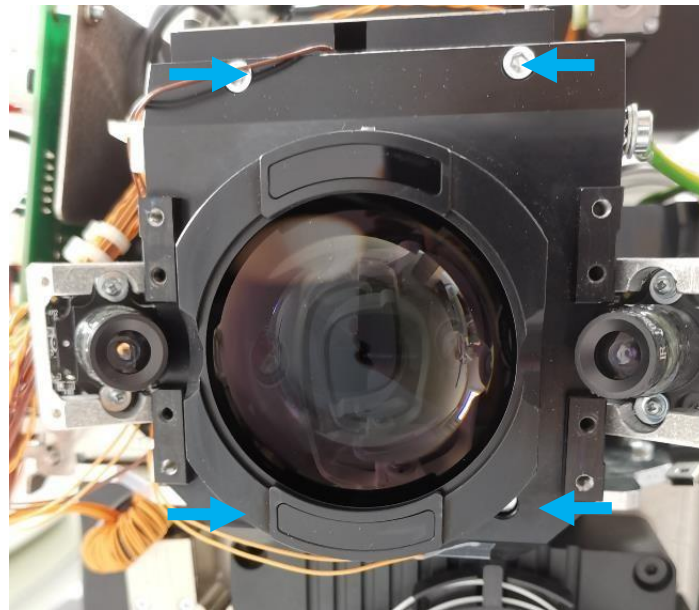

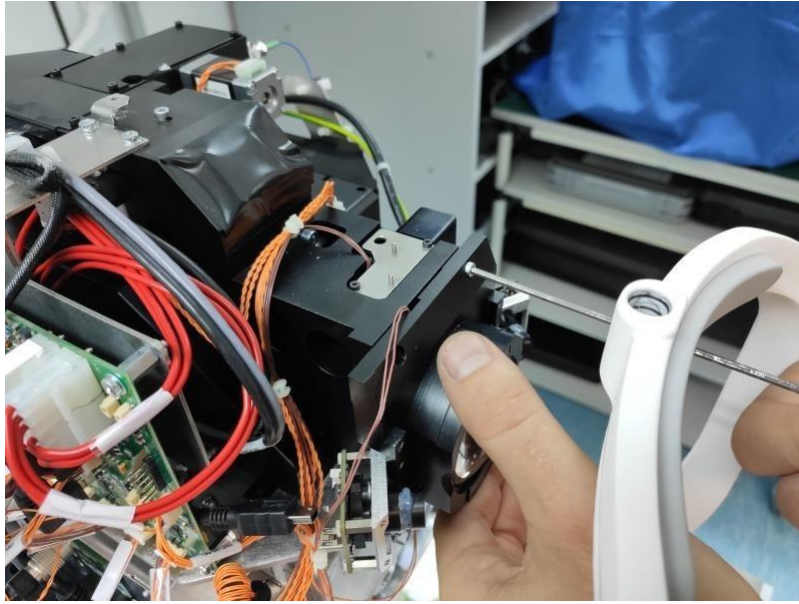

12. Carefully slide the lens out of the mount. Using compressed air and a cleaning kit, clean the optics - both sides of the lens if necessary.
13. Cleaning should be done with cleaning paper along with alcohol, using circular, even movements from the center of the lens outward. Another way is to wipe the lens from top to bottom.

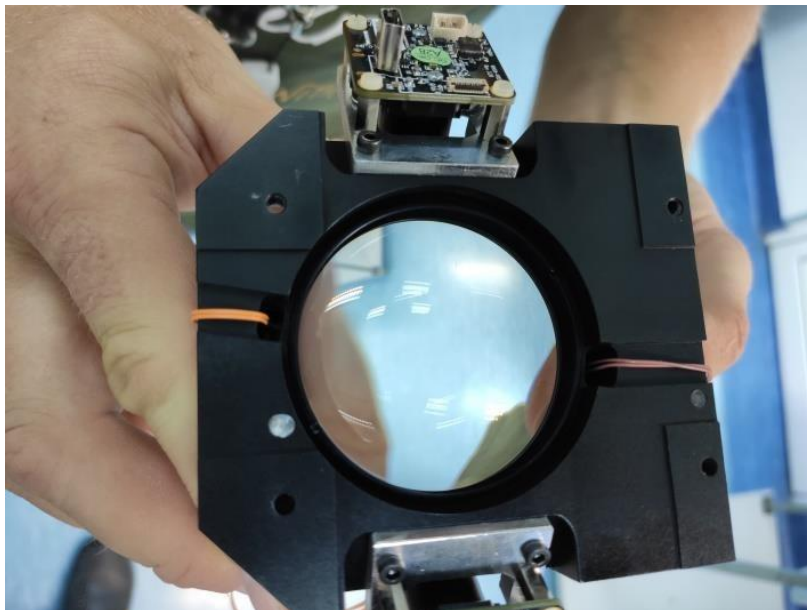

**CAUTION: When accessing electronic components, it is strongly recommended to use electrostatic discharge protection. All electronic components are sensitive to electrostatic discharge.**

14. Before reinstalling the lens, make sure the wires are in the correct position. Do not allow the wires to be damaged. If the wires are damaged, the lens module may need to be replaced.

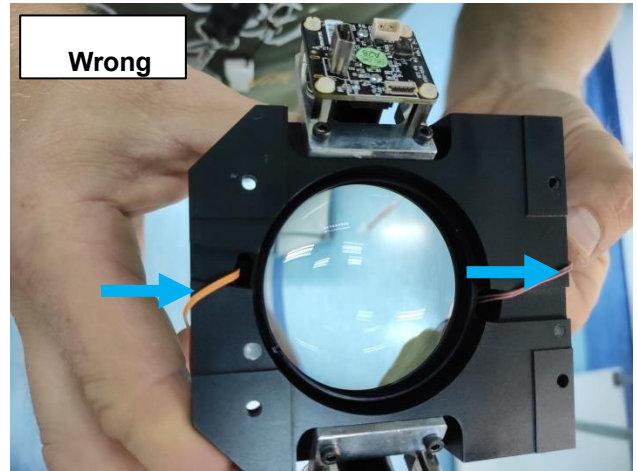
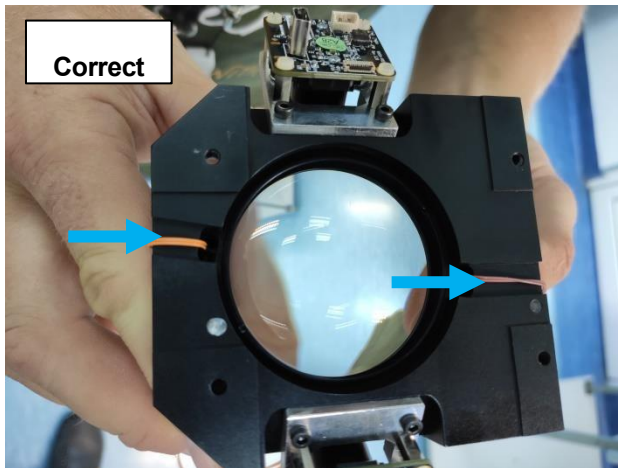

15. Reinstall the lens - make sure the pins fit into the holes and are in the right place. Tighten the 4 screws with a 2.5mm allen wrench.

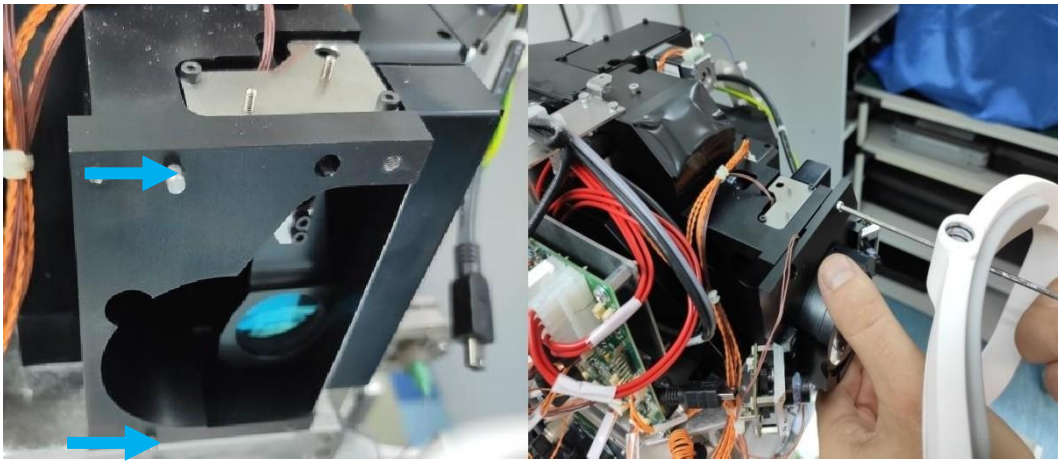

16. After assembling the lens, use, for example, insulating tape to seal any open spaces (marked in red) where dirt can get in. This will prevent the inside of the lens from getting dirty again.

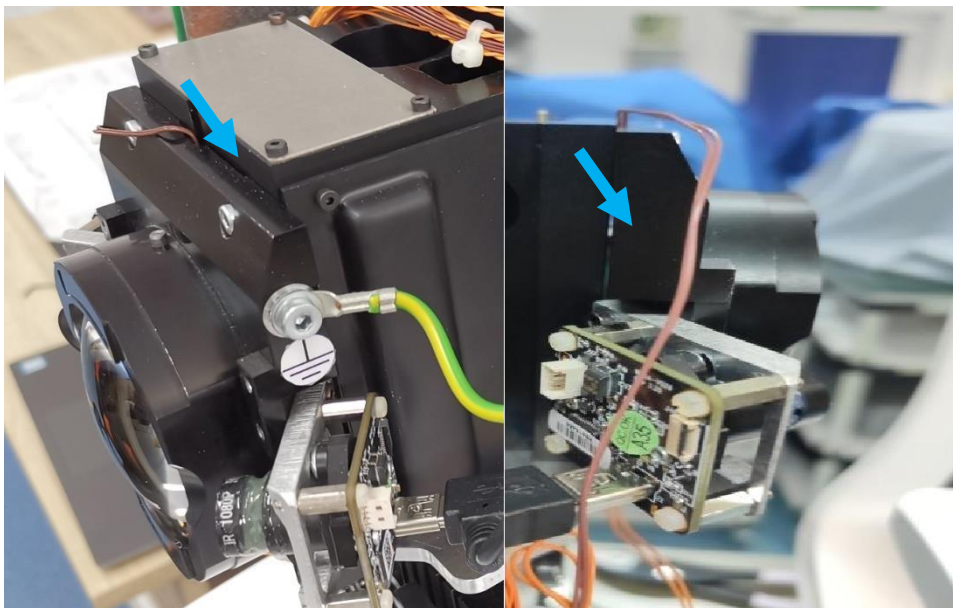

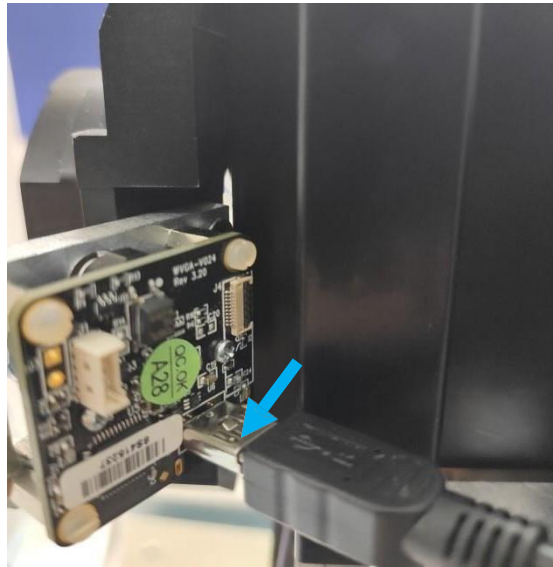

17. Connect all the wires

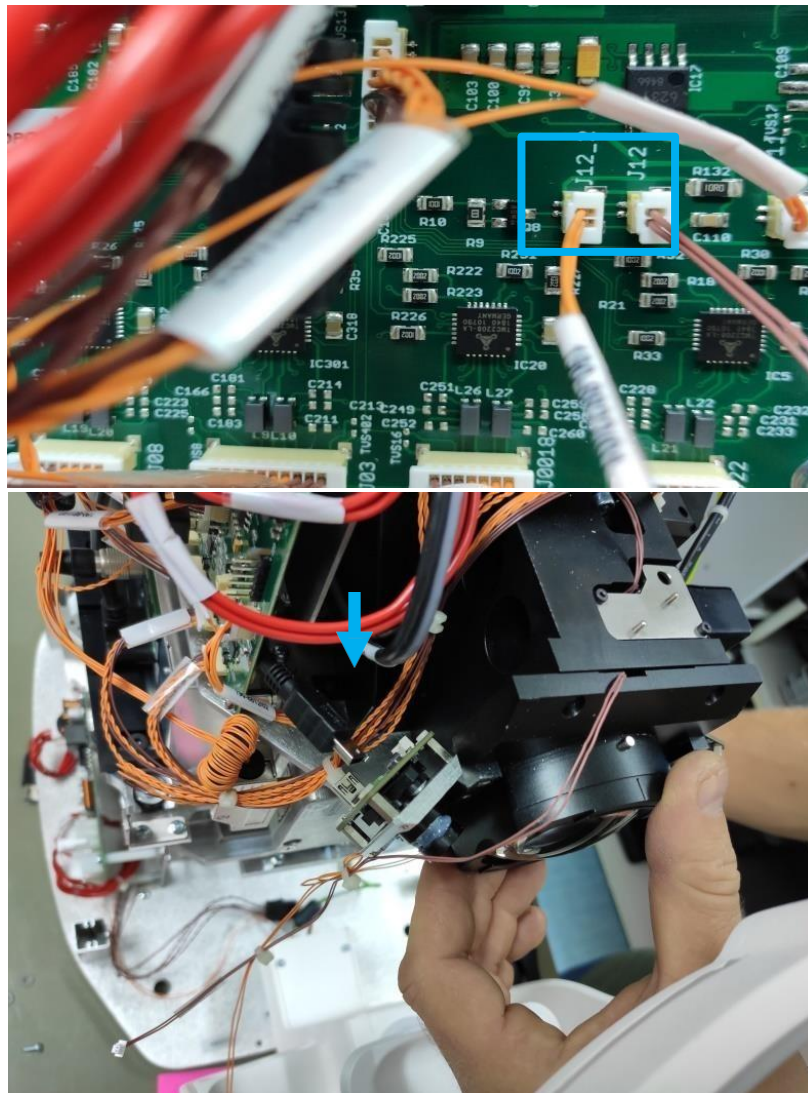

18. Perform a test of the device.

## 6.2. CCD cleaning

Tools required: KG1, cleaning papers, cleaning stick Supported devices: 190, 193, 194

Typical artifacts caused by dust particles on the surface of a CCD camera look like dark spots on a fundus photo.

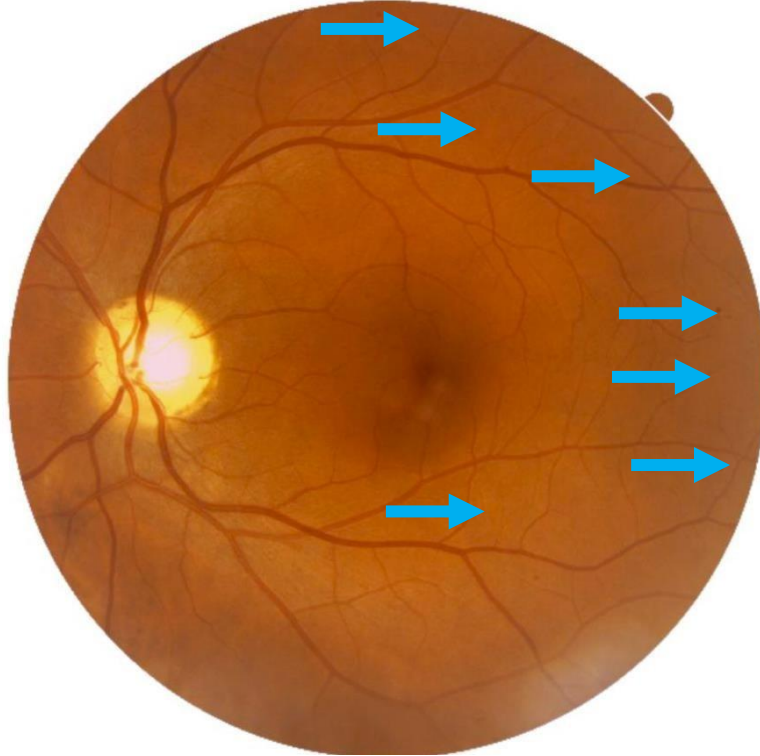

1. Open the upper housing of the SOCT
2. Remove the FC capacitor
3. Get to the CCD sensor



- The CCD surface can be accessed with a long wooden rod.

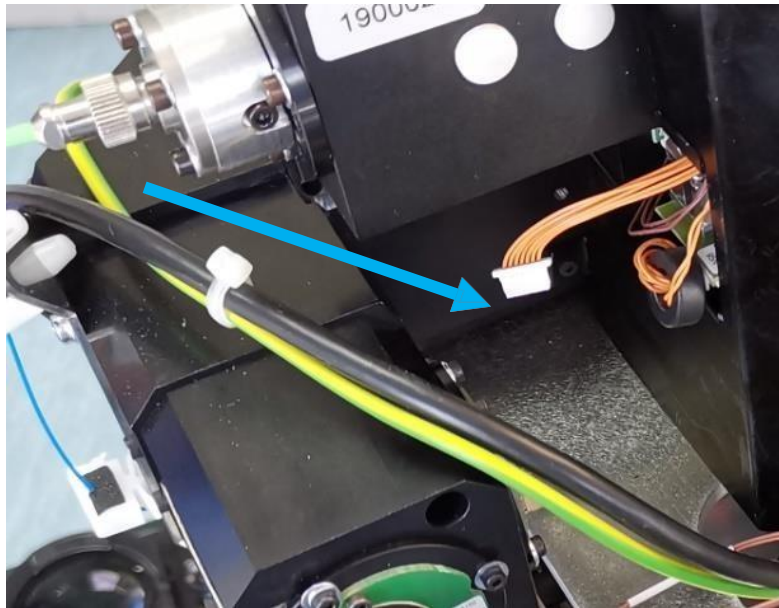

- Prepare cleaning paper and a wooden soft stick (chopsticks can be useful).



- Use compressed air to remove all dust particles.

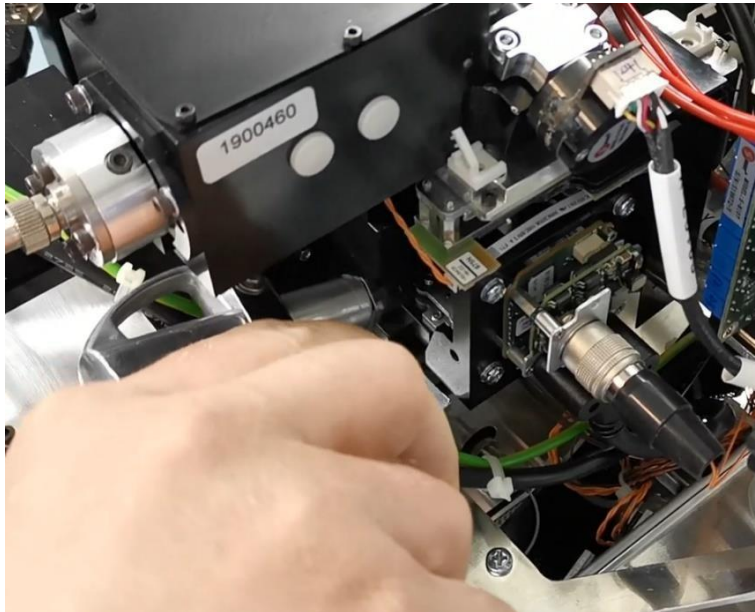

7. Apply KG1 cleaning fluid or other fast evaporating cleaning fluid to the paper and wipe the surface of the CCD. Then use compressed air again. After cleaning, close the cover immediately.

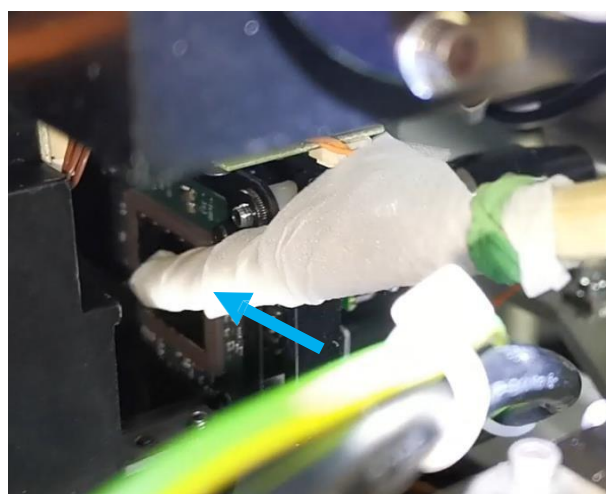
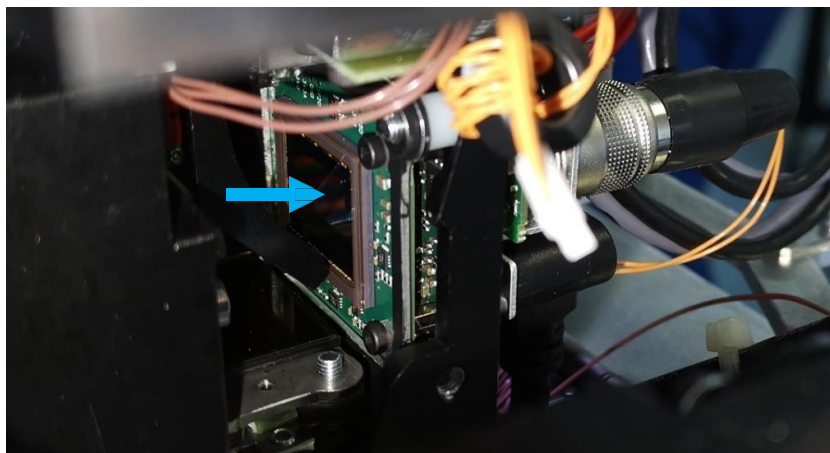

8. Sliding should be done from the inside out.
9. Now clean the inner part of the OLED screen. Slide your finger from outside to inside and pull your finger out at the end.

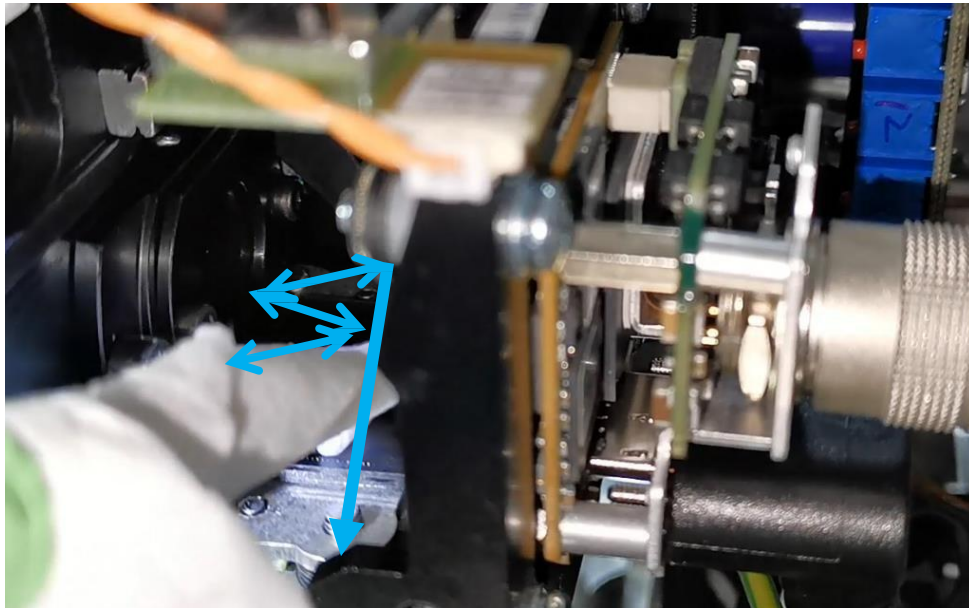

7. Close the case.
8. Install capacitor
9. Check photo quality
10. The best way to check whether any artifacts remain is to take a photo of the hand from 2-3 cm from the center of the forehead rest.



### 6.3. Cleaning of scanner mirrors

Tools required: KG1, cleaning papers, cleaning stick Supported devices: 155, 156, 190, 191, 192, 193, 194

Clean the surfaces of the mirrors with a soft brush, then remove the particles with a dust remover. If necessary, remove the scanner motor for cleaning, then follow the instructions in the relevant section to return it to the correct position.

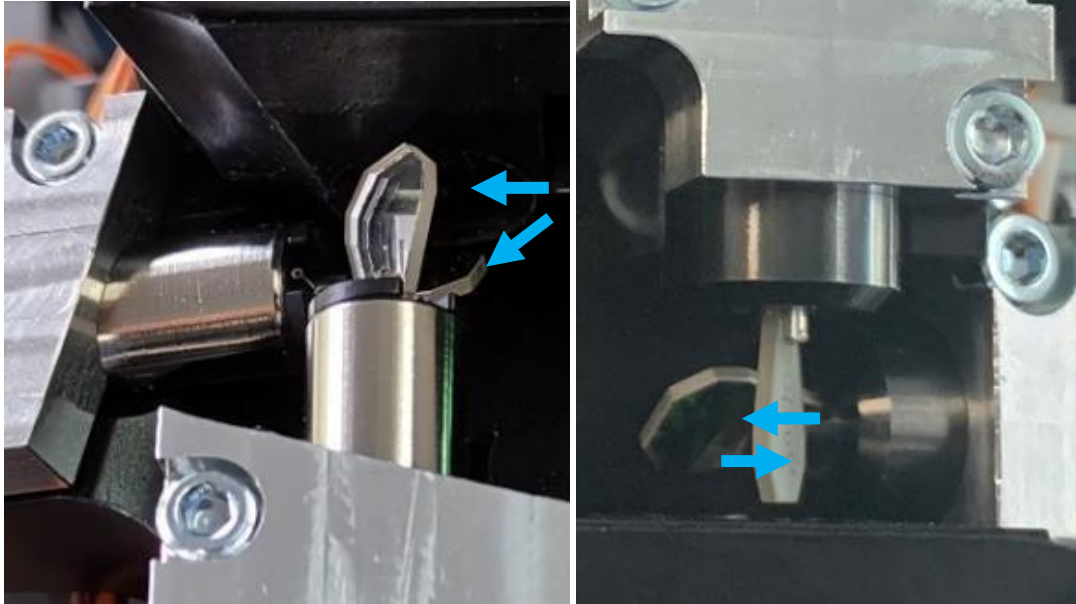

## 6.4. Blackspot check

Required tools: none Supported

devices:190, 193, 194

**NOTE:** For devices with a funduscamera module, blackspot extinction should be evaluated.

**Especially in devices below the serial number:**

- 1906022
- 1935201

Below is an example of an abnormal fundus image with a clearly visible central reflection. Note that the image may vary depending on the patient's eye and acquisition condition. Note that the reflection can appear even on a properly functioning device if the minimum pupil size is not correct (3.6mm).

It is recommended to clean the optics - the lens inside and outside (use a dedicated cleaning kit),and then perform FC reflex calibration according to the service manual. Take test shots to see if there is an improvement. If the central reflection is still visible, proceed to the next steps.

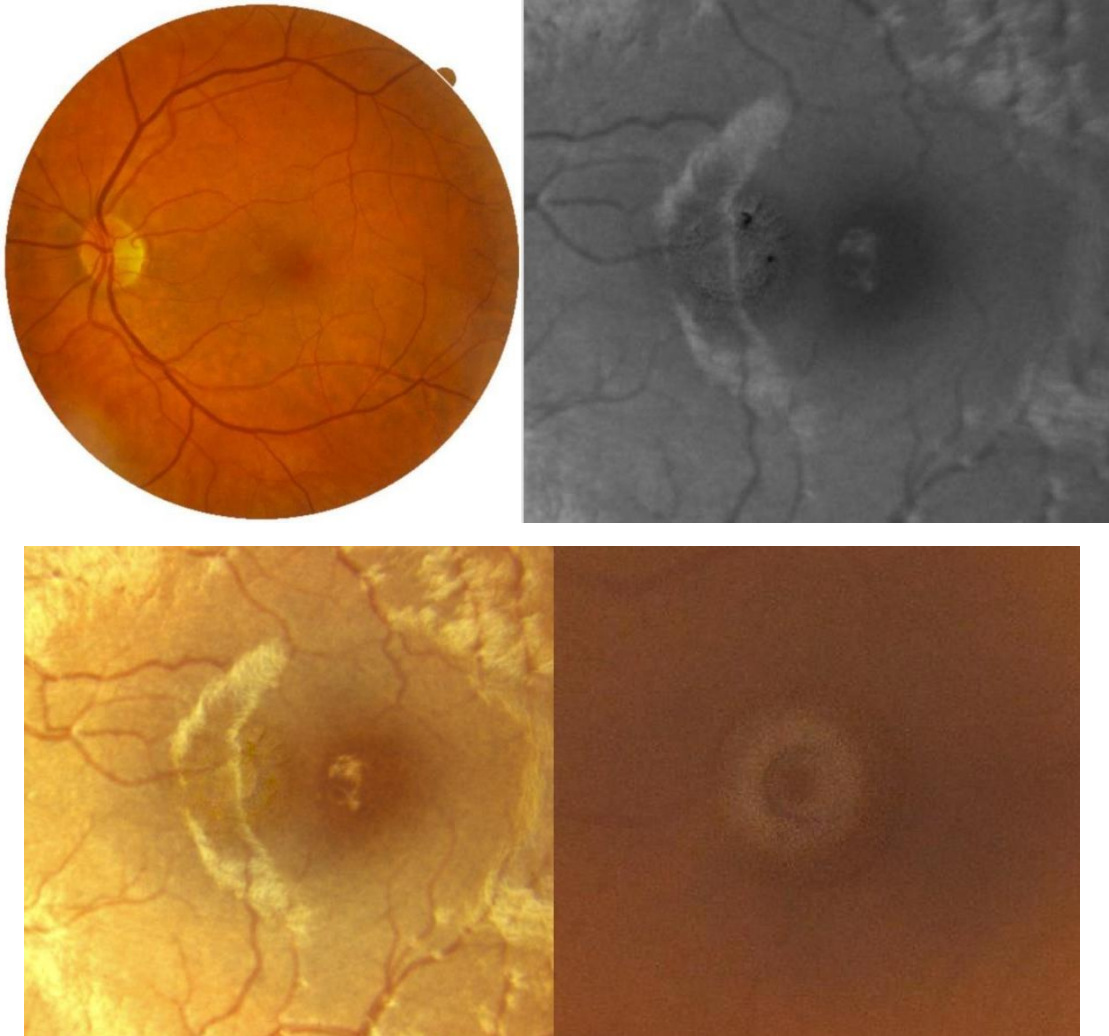

To check if the black spot needs to be replaced or if it has moved and needs position calibration, follow the steps below.

- Connect the device to the computer, start the device
- Make sure the appropriate calib file is in the calib folder [C:\ProgramFiles XX.X.X.Calib].
- Run the latest **Scantest2** diagnostic software

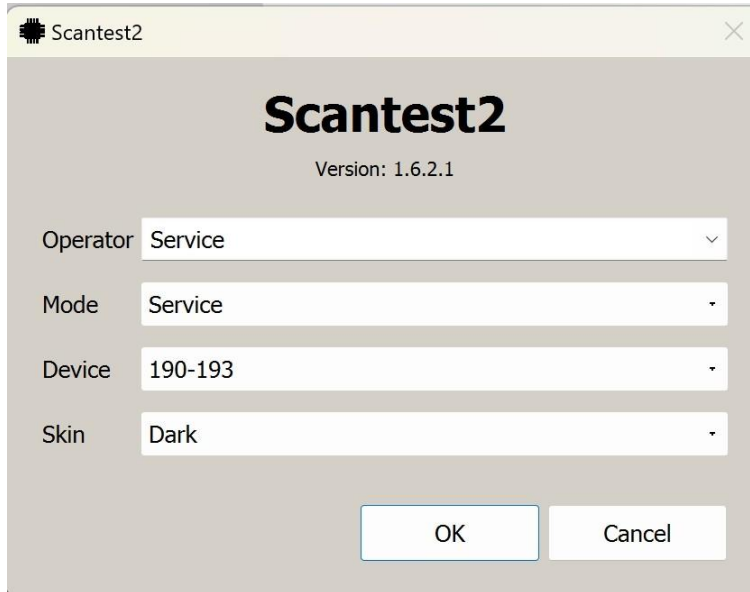

- Press OK , then press Start on the Begin tab to connect the device.
- Use the **Next** buttons to move to the **Fundus camera** tab. Press **Start** and open the toolbox to change the **FIXATION FOCUS** to **-25.00 D**.

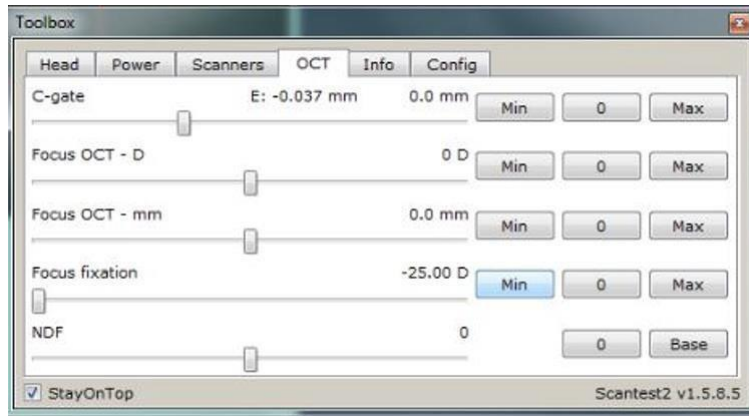

- If the following settings do not fit, change them: **Gain to 10** and **Flash Power to 3000**. Deselect **HDR** and **Hot pixels**. Select the Auto Attract option.

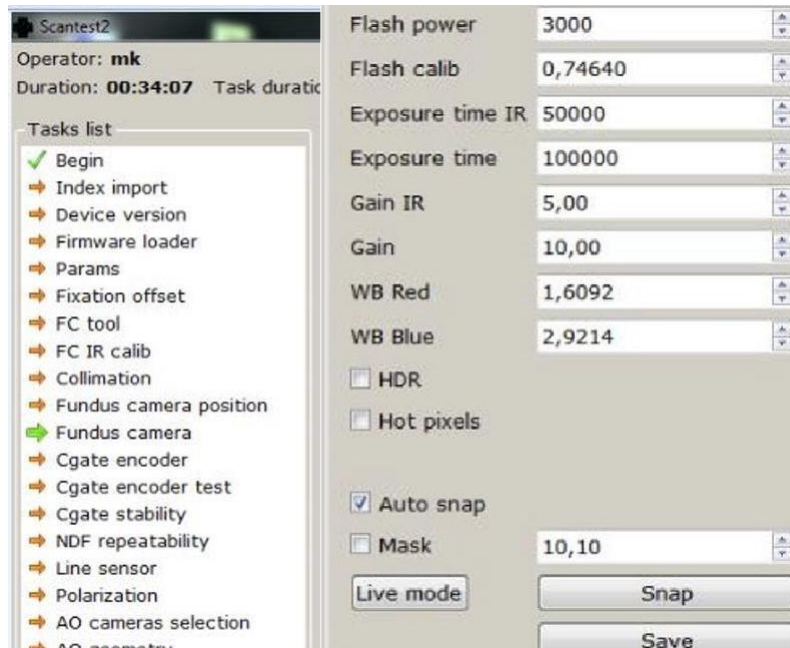

- It is recommended to place the device in a suitable room, **DO NOT** place any objects in front of the device, do not stand in front of the lens.
- Observe the image in the center of the photo, use the **CTRL** key and **scroll** to enlarge the central area and see if the black spot is in the right position.

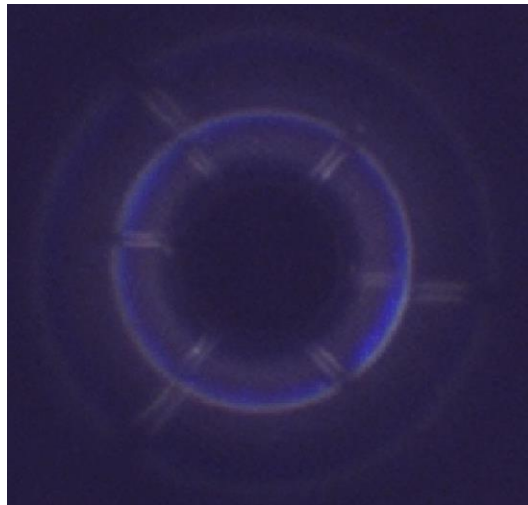

An example of the correct position of the black spot. However, this image confirms that this BS type should be replaced. Notice that the blue reflections on the edges are much brighter than in the new BS type below.

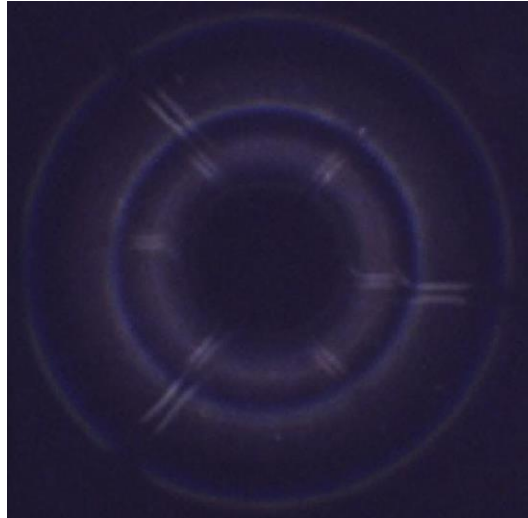

- If you notice below the image - the lack of symmetry in the bright reflections, the BS should be aligned, and then verify the quality of the image, as there is a chance that the BS does not need to be replaced.

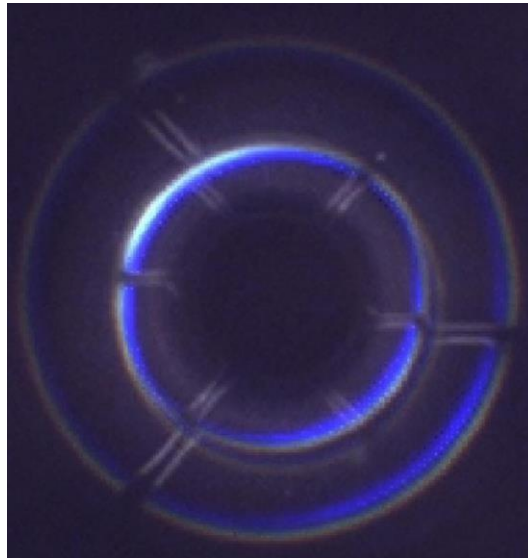

- If you decide that the BS will be replaced, take a screen of the real position to be a reference.

## 7. Checking the position of the scanning cross with respect to internal fixation

1. Open Scantest\_2, go to the Exam tab and press the [Start] button. You will see a live preview and a black screen with noise, which means the scanners are moving and you can look into the lens. If necessary, use the HEAD tab to move the head of the device for easier access.
2. Now check if the red crosshairs coincide with the center of the green setting crosshairs. Look through the lens and if the cross does not coincide in any axis. If the cross overlaps, proceed to the next steps of checking the device. If it does not overlap, check the positions of the fixation cross | scanners based on the service manual.

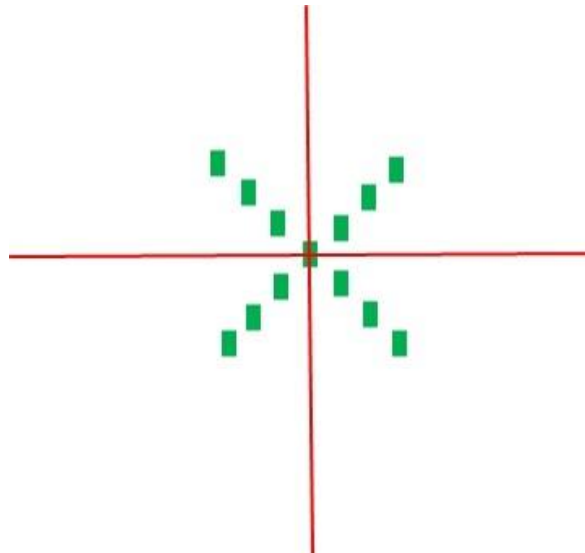

## 8. Checking the position of the preview cameras

### 8.1. Single lens (convex) lens

Tool needed:

- T190-3020

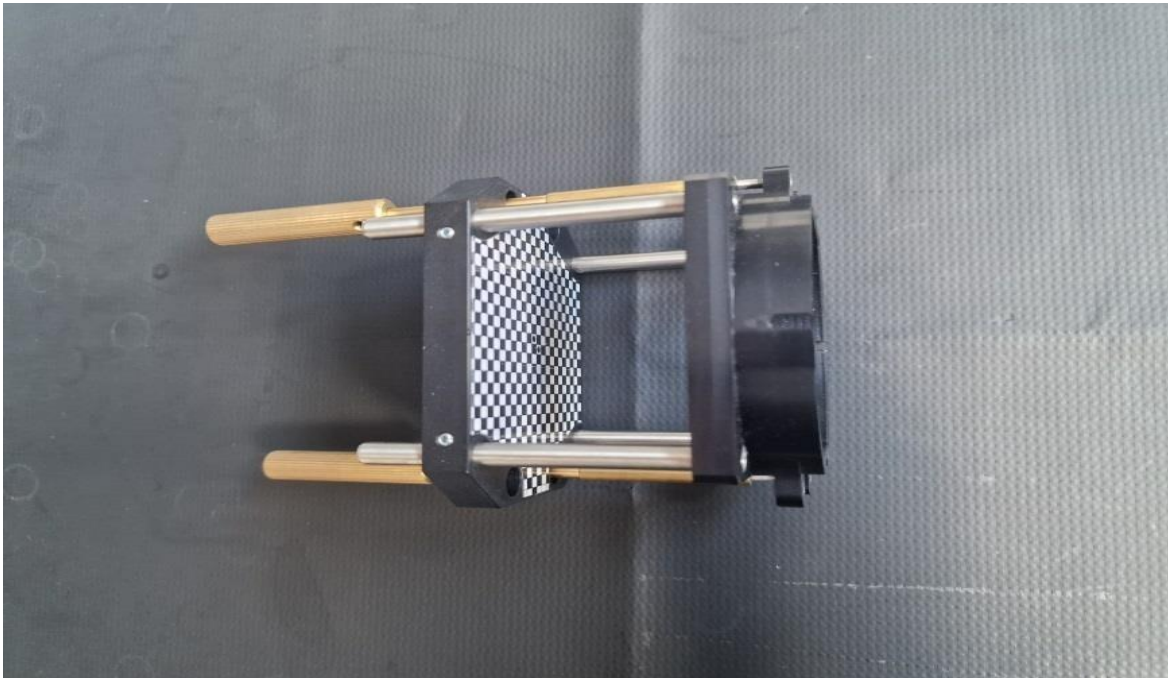

The task is to check the position of the two front cameras on either side of the main lens.



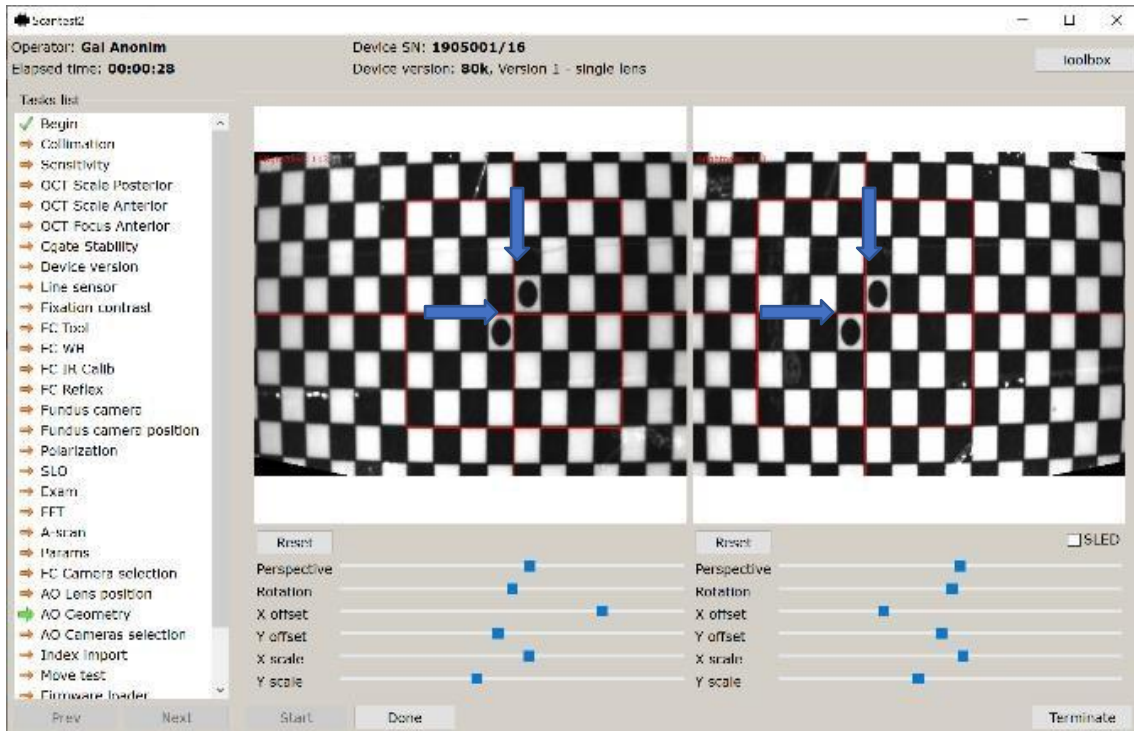

For this task, a special tool is used, mounted on the main lens of the device. To facilitate the installation of this tool, when this task is started, the head of the device, instead of moving to the base position, it moves below this position to avoid collision of the tool with the support of the forehead.

First, the operator for the default slider settings sets the position of the camera lenses mechanically, as precisely as possible. If the lenses are already roughly mechanically set, then adjust the pattern from the tool so that it fits into the red rectangle as in the image above using the sliders below the cameras' image. Both lenses and image position are set independently for the left and right cameras. Under the images from both preview cameras, two sets of controls are displayed (separately for the left and right cameras):

- Reset button - allows you to set the sliders to the default position
- Perspective slider - allows you to adjust the perspective of the image
- Rotation slider - allows you to adjust the rotation account of the image
- X offset slider - allows you to adjust the position of the image in the horizontal axis
- Y offset slider - allows you to adjust the position of the image in the vertical axis
- X scale slider - allows you to adjust the scale of the image in the horizontal axis
- Y scale slider - allows you to adjust the scale of the image in the vertical axis
- Checkbox SLED - allows you to turn on the SLED diode and center the scanners, so you can see where on the chart the main lens axis is located

Once the lens/image position is complete, the operator presses Done to save all slider positions in the device's configuration parameters.

## 8.2. Three lenses of the lens (concave)

Tool required:

- T191-3020



The task is to check the position of the two front cameras on either side of the main lens.



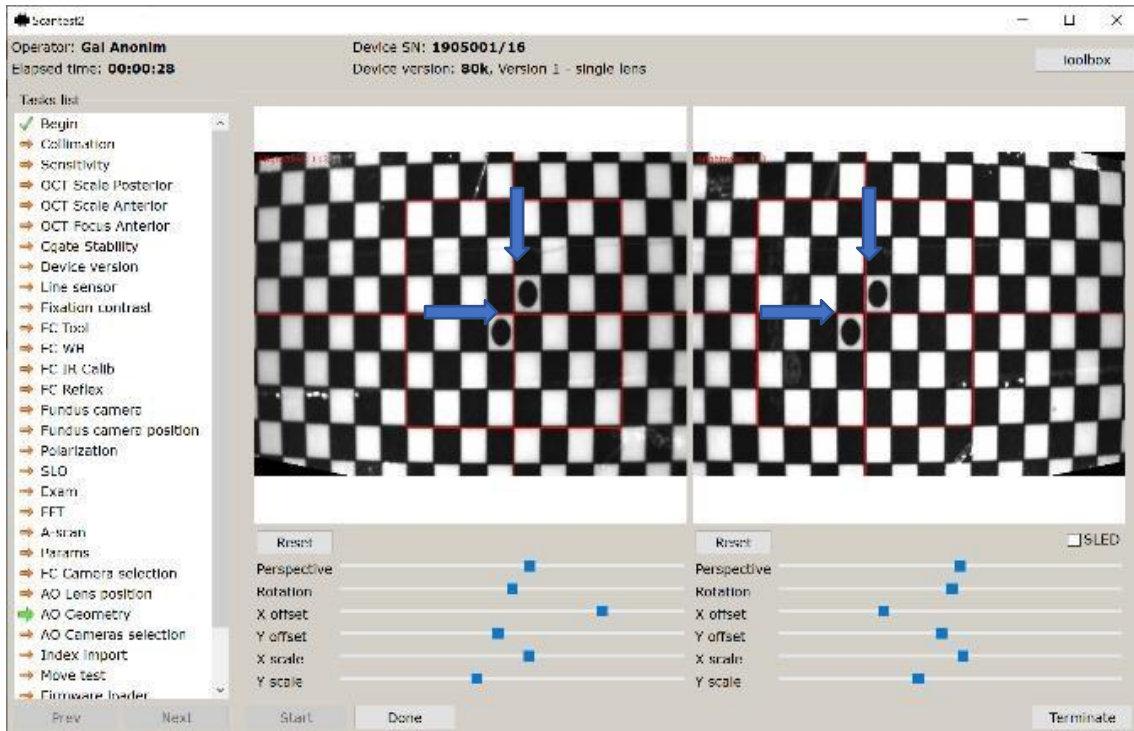

For this task, a special tool is used, mounted on the main lens of the device. To facilitate the installation of this tool, when this task is started, the head of the device, instead of moving to the base position, it moves below this position to avoid collision of the tool with the support

For the T191-3020 tool, set the scanning beam between two points visible on the tool. To do this, use a phone that can record infrared light.



In Skantest\_2, in the line sensor task, set up the scanners, then use the tool's phone and potentiometers to adjust the grid plane so that the scanning beam is between the two black dots, as shown in the image above. Once the beam is set, you can move on to setting the position of the preview cameras.

First, the operator for the default slider settings sets the position of the camera lenses mechanically, as precisely as possible. If the lenses are already roughly mechanically set, then adjust the pattern from the tool so that it fits into the red rectangle as shown in the image above using the sliders located

Under the image of the cameras. Both lenses and image position are set independently for the left and right cameras. Under the images from both preview cameras, two sets of controls (separately for the left and right cameras) are displayed:

- Reset button - allows you to set the sliders to the default position
- Perspective slider - allows you to adjust the perspective of the image
- Rotation slider - allows you to adjust the rotation account of the image
- X offset slider - allows you to adjust the position of the image in the horizontal axis
- Y offset slider - allows you to adjust the position of the image in the vertical axis
- X scale slider - allows you to adjust the scale of the image in the horizontal axis
- Y scale slider - allows you to adjust the scale of the image in the vertical axis
- Checkbox SLED - allows you to turn on the SLED diode and center the scanners, so you can see where on the chart the main lens axis is located

Once the lens/image position is complete, the operator presses Done to save all slider positions in the device's configuration parameters.

### 8.3. Lens in 155xxx; 156xxx devices

Tool required:

- T155-3020
- Applies to devices: 155, 156

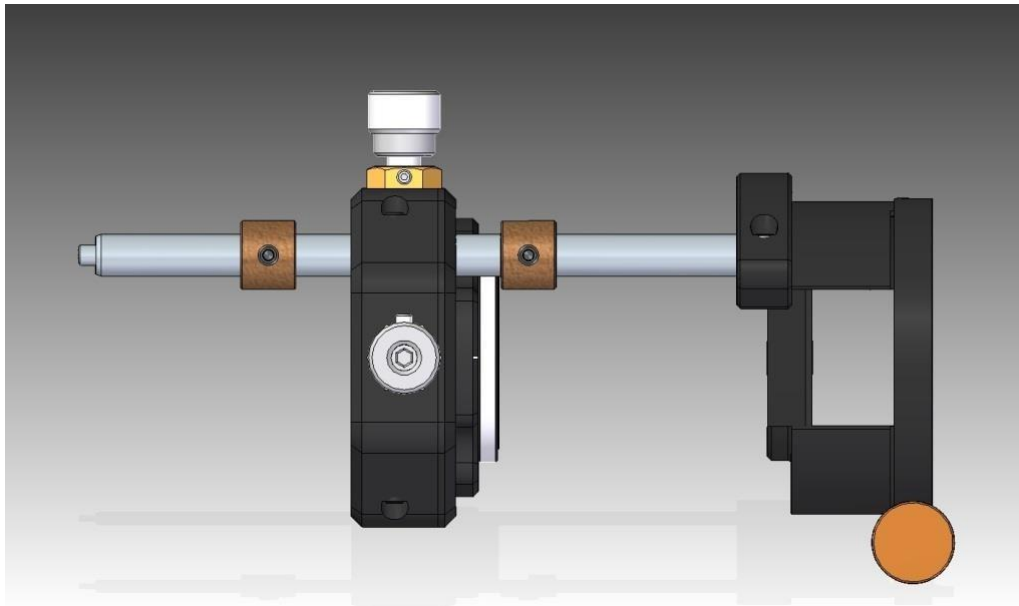

1. Attach the tool to check the position of the cameras. Make sure the top part is properly attached with the positioning pin, then tighten the mounting screw on the bottom part.

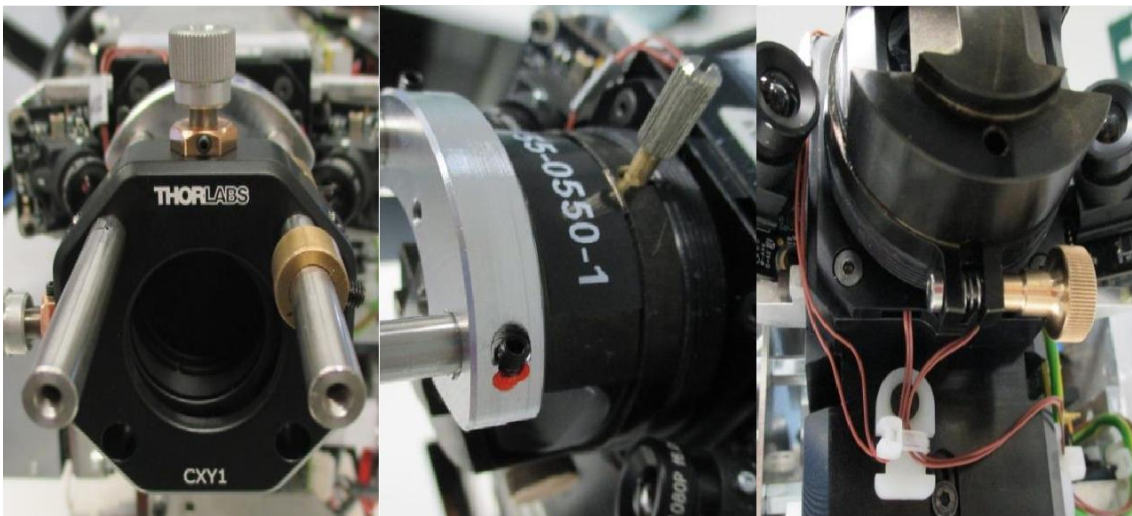

2. For the T155-3020 tool, set the scanning beam between two points visible on the tool. To do this, use a phone that can record infrared light.



3. If the beam is not in the center, use both screws to move the beam to the center position. Move it in the direction of the device. The following are examples of the incorrect position of the beam relative to the checkerboard.



4. After correcting the position of the checkerboard, move it backward until the back of the viewfinder touches the mark.

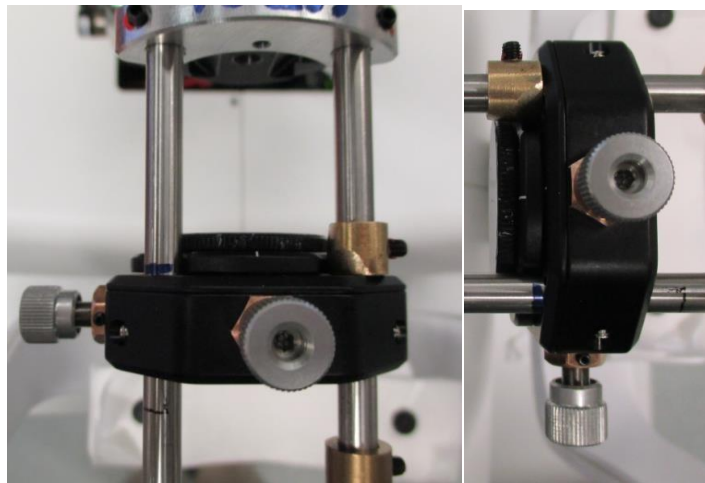

First, the operator for the default slider settings sets the position of the camera lenses mechanically, as precisely as possible. If the lenses are already roughly mechanically set, then adjust the pattern from the tool so that it fits into the red rectangle as in the image above using the sliders below the cameras' image. Both lenses and image position are set independently for the left and right cameras. Under the images from both preview cameras, two sets of controls are displayed (separately for the left and right cameras):

- Reset button - allows you to set the sliders to the default position
- Perspective slider - allows you to adjust the perspective of the image
- Rotation slider - allows you to adjust the rotation account of the image
- X offset slider - allows you to adjust the position of the image in the horizontal axis
- Y offset slider - allows you to adjust the position of the image in the vertical axis
- X scale slider - allows you to adjust the scale of the image in the horizontal axis
- Y scale slider - allows you to adjust the scale of the image in the vertical axis
- Checkbox SLED - allows you to turn on the SLED diode and center the scanners, so you can see where on the chart the main lens axis is located

Once the lens/image position setting is complete, the operator presses Done to save all slider positions in the device's configuration parameters.

## 9. Verification / Polarity Corrector

Tools required: Scantest\_2, Flat wrench 5.5, Allen wrench 2.5, Artificial eye Supported

devices:155,156,190,191,192,193,194

**NOTE: Changing the alignment of the fiber optics has a direct effect on the final spectral height and power on the lens. Remember to check the power and spectrum each time after adjusting the polarization**

1. Below is an example of incorrect/correct polarity adjustment. This problem can occur after transporting the device in poor conditions. In this case, the saturation of the scans is not satisfactory, even though the power and spectrum are within the correct values. In some cases, incorrect polarization adjustment causes a difference in scan quality between the right and left eyes.

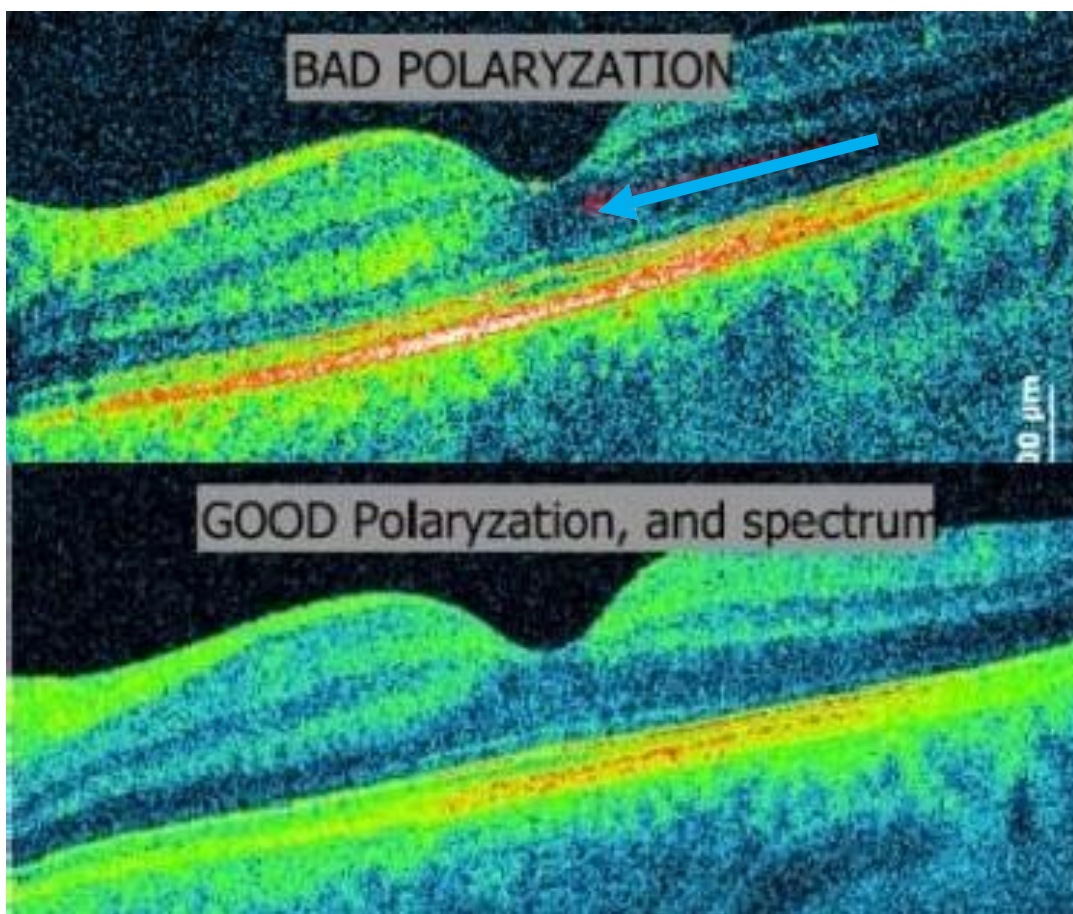

2. If you have checked all the parameters, but the scan still has bad quality/saturation, you need to adjust the polarity.
3. Open SOCT head
4. Turn on the device.
5. Start the **Scantest\_2** tool, select the device type, in the **Start** task section press **Start**. Open the toolbox and select "Mirror OCT" if applicable.
6. Next, check the boxes for SLED and scanners. Go to the OCT tab and press MAX in the Focus OCT- D section, then press 0D. Set the C-gate position to the 0 position.

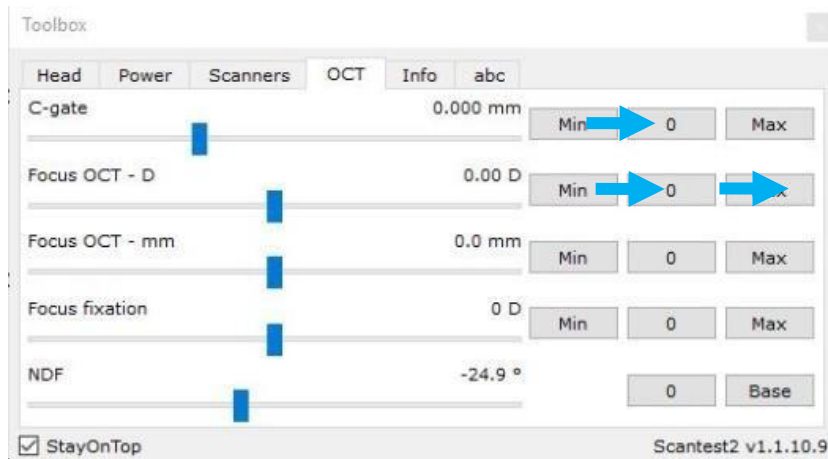
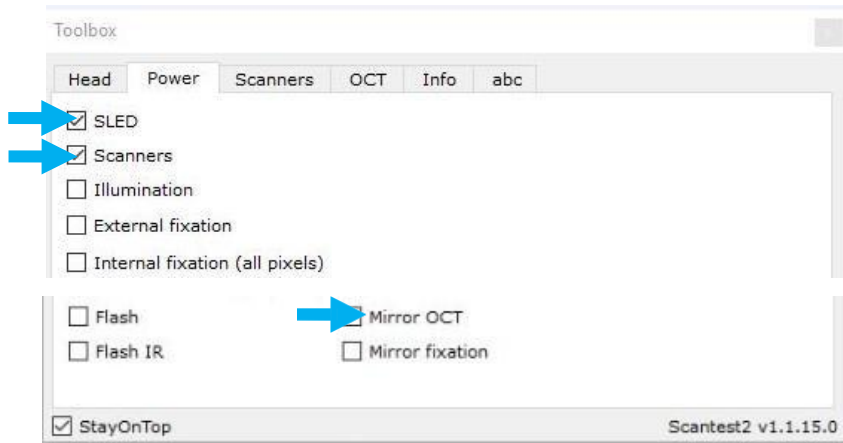

- Use the [Next] button to select the Polarization tab. Press [Start]. In the upper right corner you will see sliders that allow you to change the value of "NDF", "Focus", "ScannerX," "ScannerY" and "Cgate."

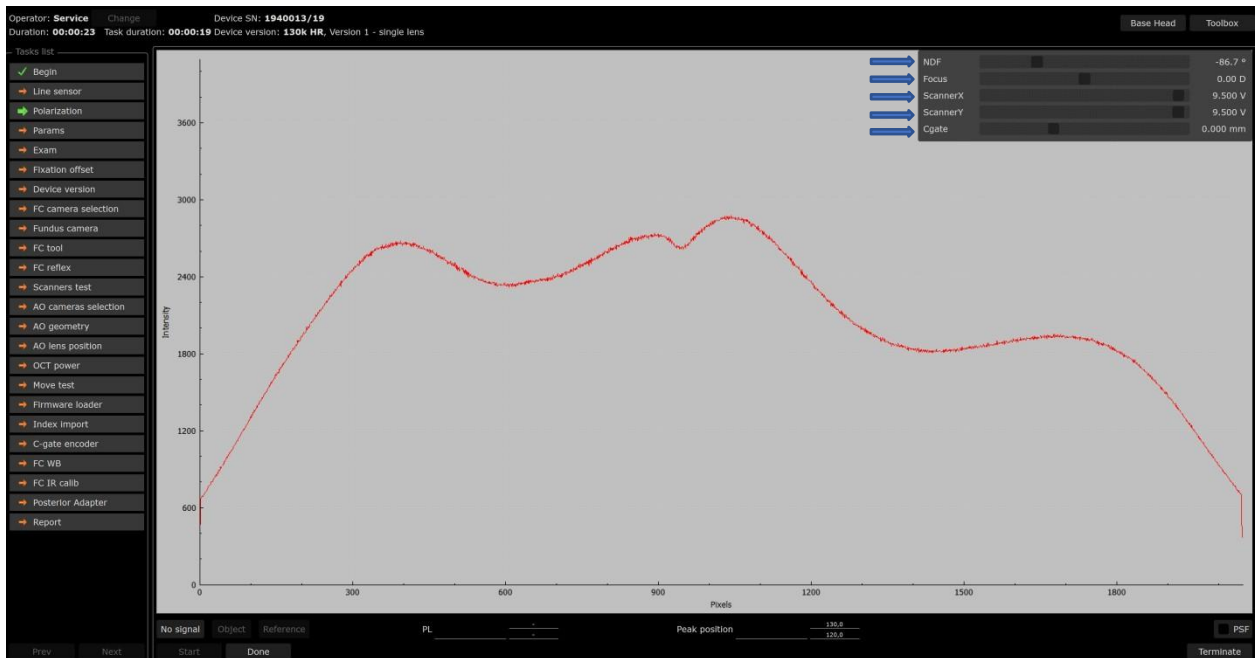

- In the lower left corner are the "No signal", "Object" and "Referance" buttons.

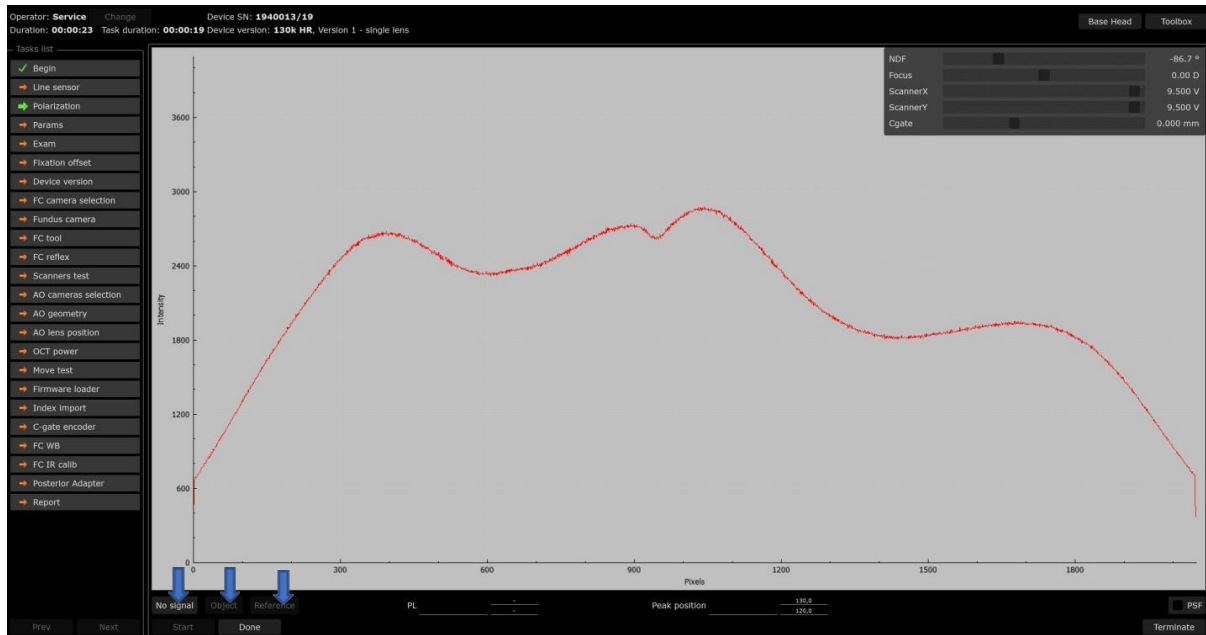

9. First, use the "NDF" slider to set the minimum height of the spectrum - the red line of the signal will turn green when the appropriate setting is reached. If the line does not change color, lower it as low as possible. Then press the "No signal" button.

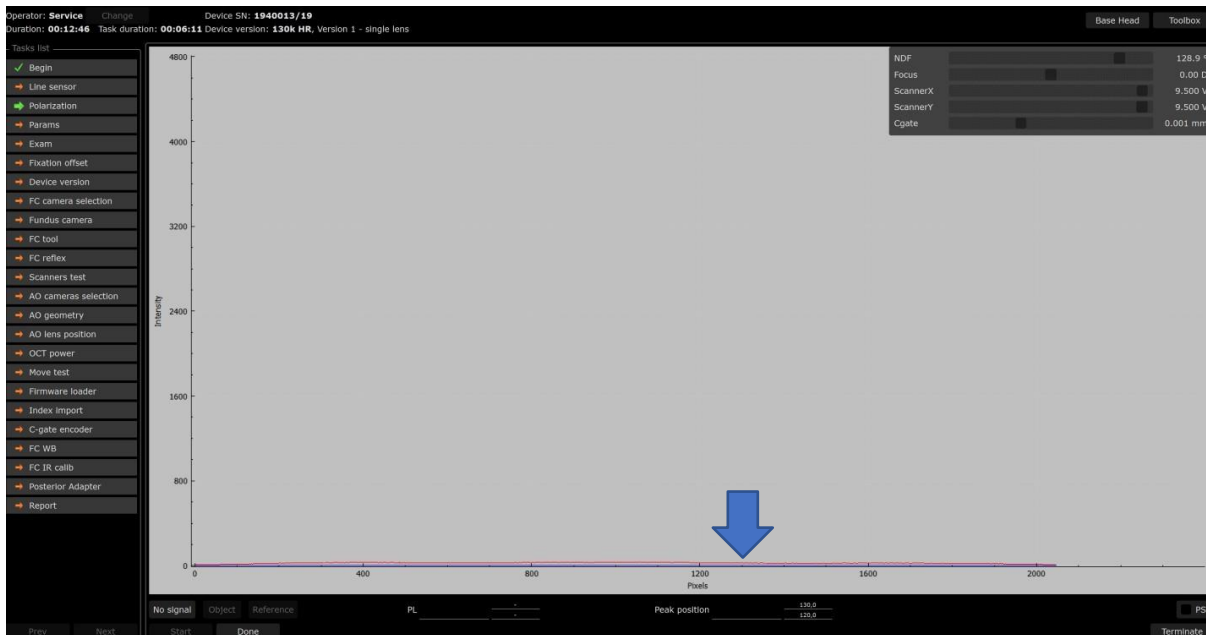

10. Mount the artificial eye (TFC001) on the lens, Fit the top pin to the hole in the tool and attach to the device with two screws. Do not turn the 3 knobs on the artificial eye.

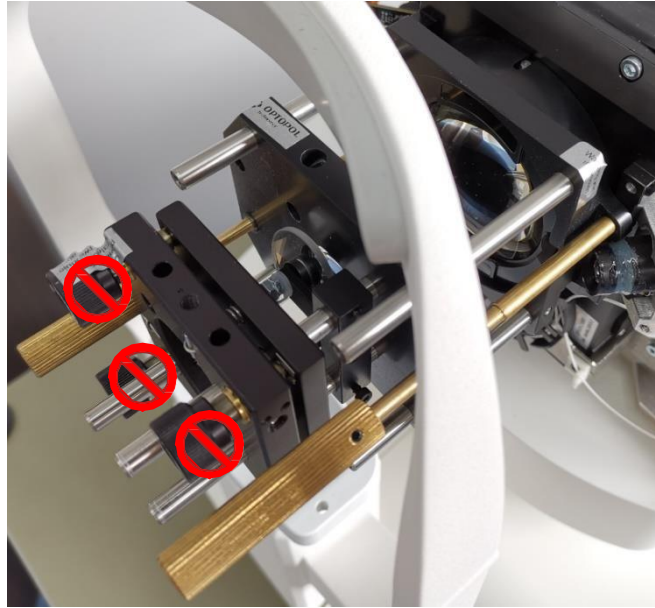

11. Set the maximum height of the spectrum using the sliders "Focus", "Scanner X" and "Scanner Y". If the spectrum extends beyond the visible scale, adjust the height with the Artificial Eye NDF filter

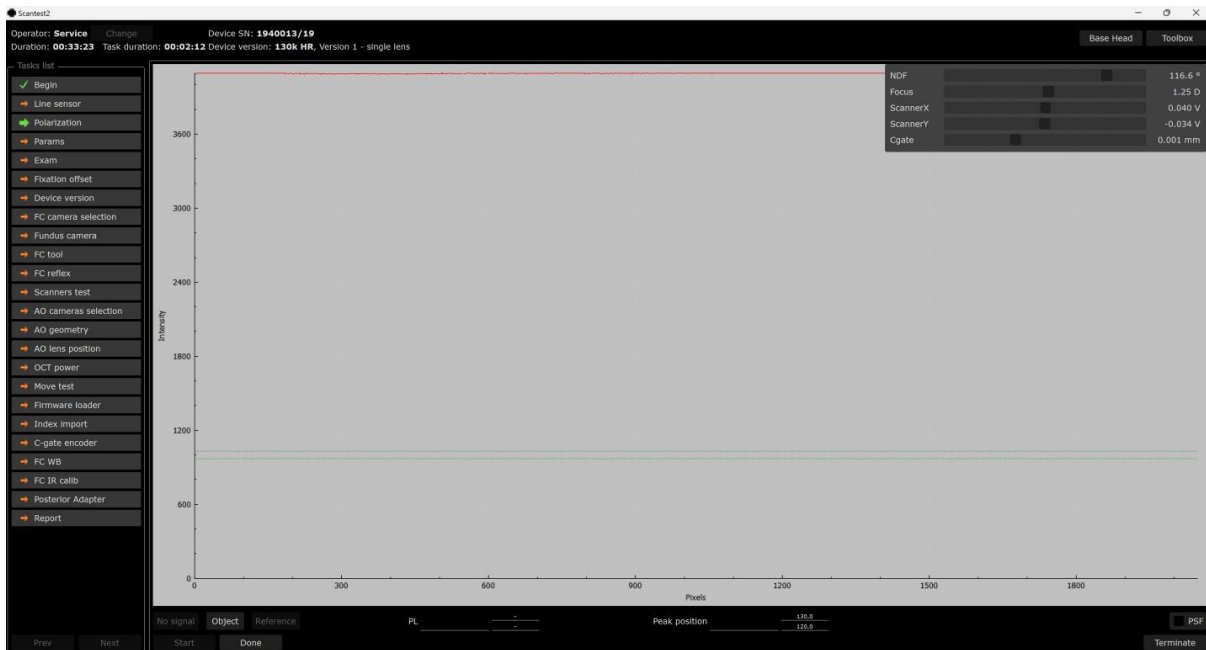

12. After reaching the maximum height using the sliders, adjust the height of the spectrum between the green horizontal lines using the NDF filter in Artificial Eye. Then press the "Object" button.

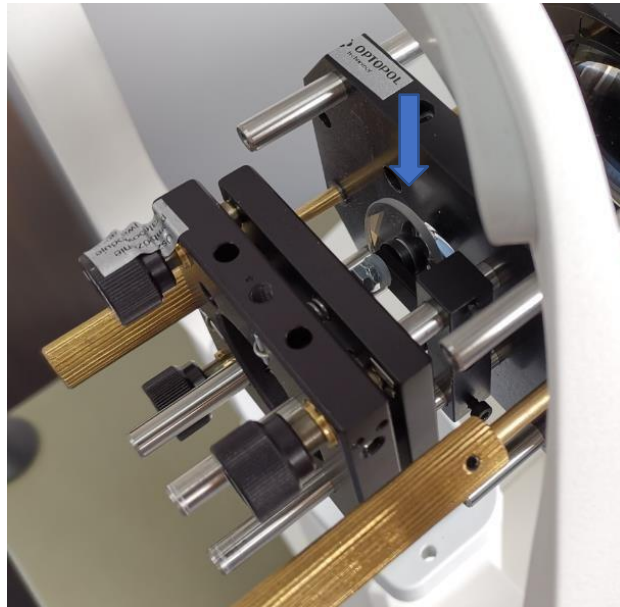
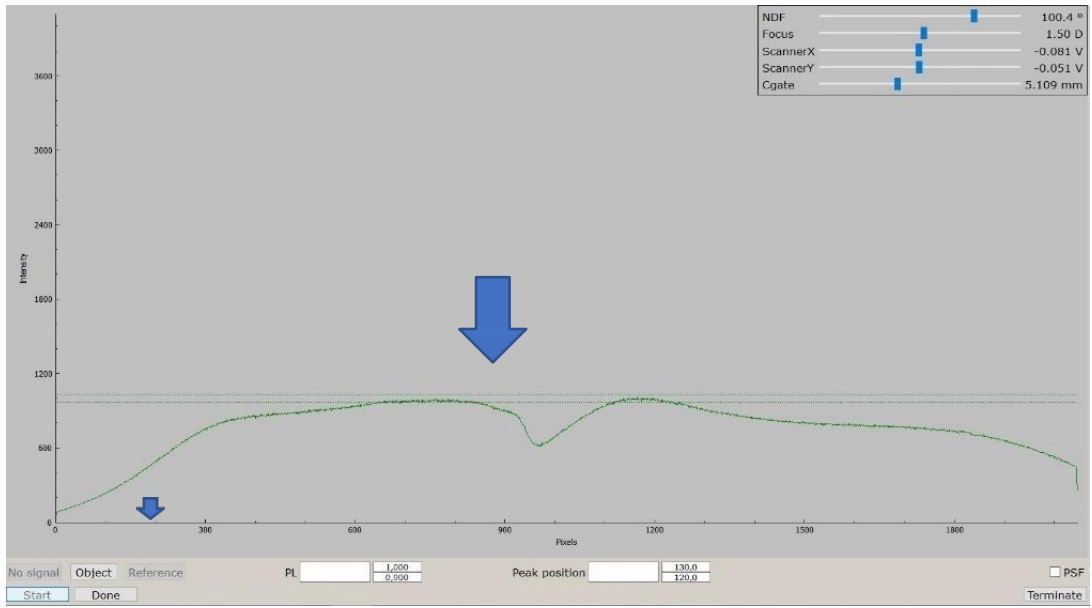

- Use the "NDF" slider to adjust the height of the spectrum between the green horizontal lines, and then press the "Reference" button.



- Move the C-gate control slider sideways until the following interference pattern appears. The line density must be the same. For fine adjustment, use the keyboard arrows </>.

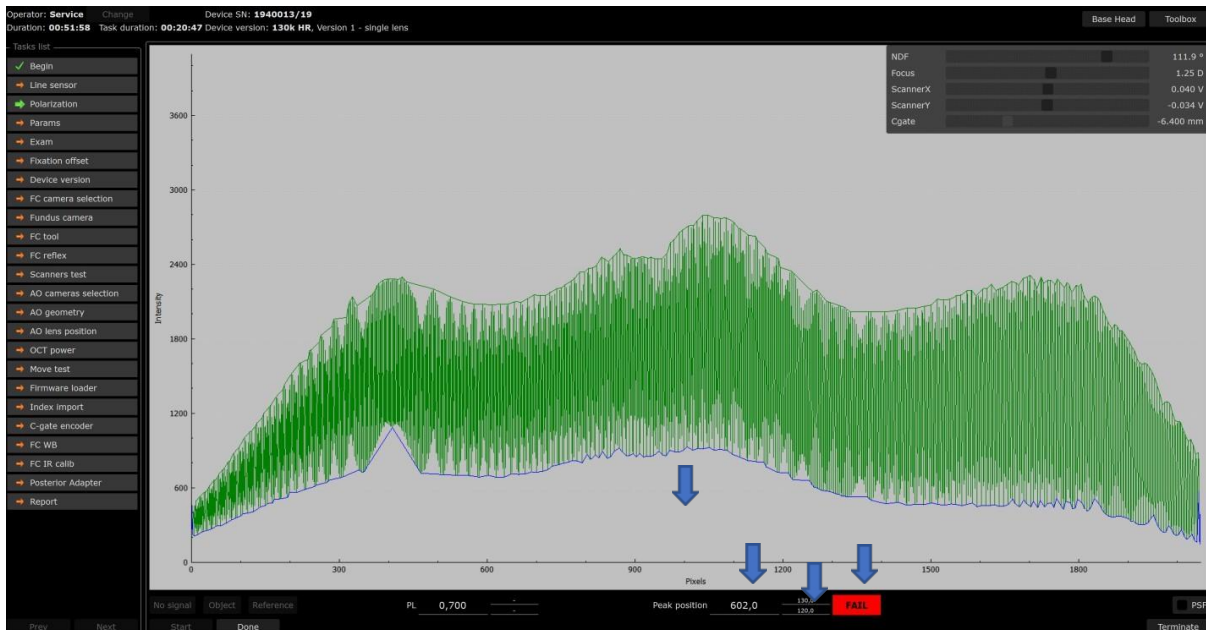

- Loosen the screws - with a 5.5 wrench securing all polarization controllers so that they are fixed, but can be moved. Rotate them up/down to lower the lower spectral line as much as possible (a green PASS sign will appear). Try to achieve the highest PL ratio (ideal is 0.96). **Be careful not to bend or break the optical fiber !**

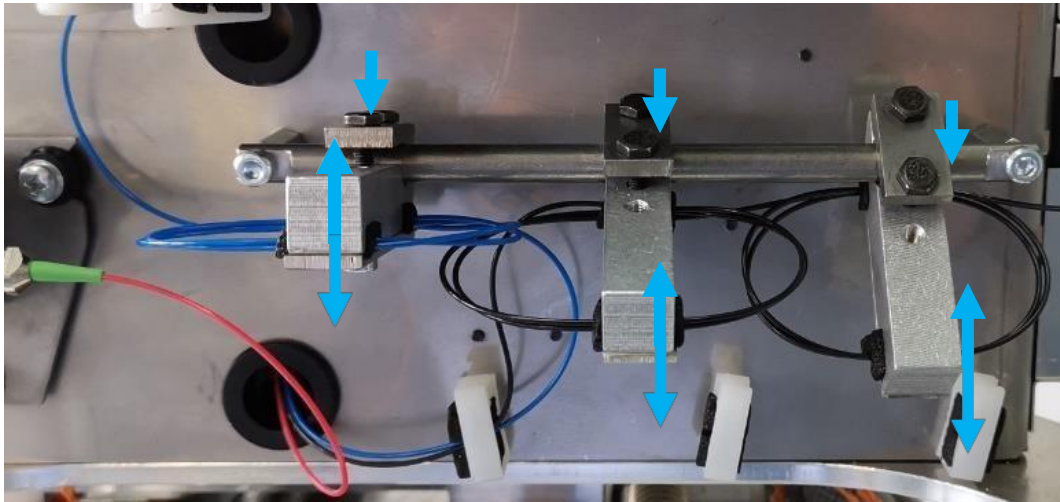

Move each polarization controller up/down and observe the changes in the interference pattern until you get the best PL indicator.

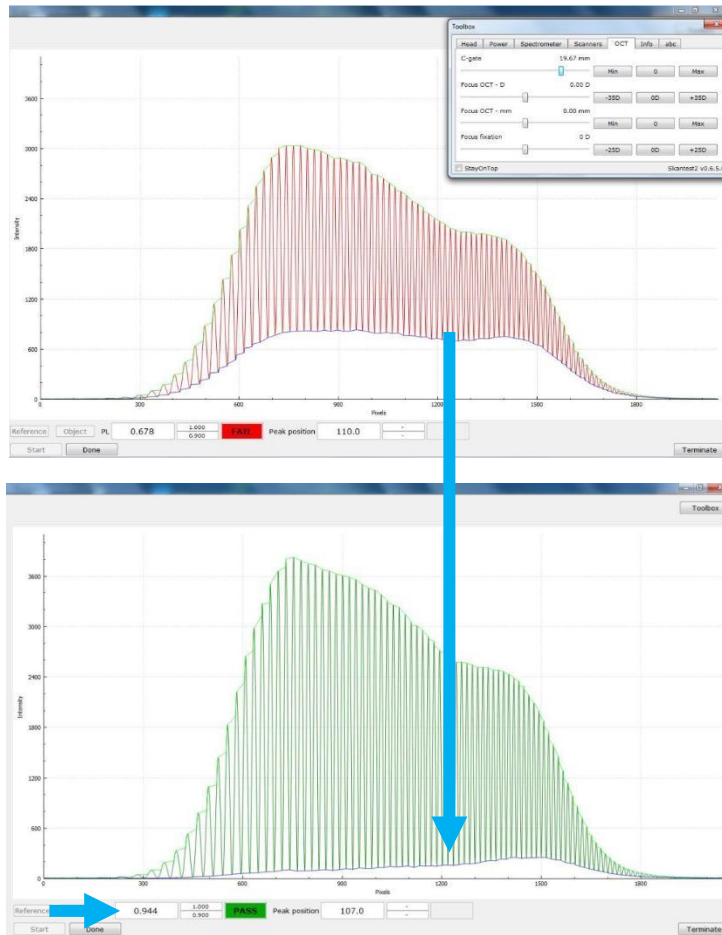

16. The image above shows a good polarity pattern. After adjusting the controllers to positions that provide the best PI, tighten the 5.5mm screws. Press the [Done] button to save the settings in the final report.
17. Remove the artificial eye, open the line sensor tab and press the start button. If the spectrum is not in the right position, open the toolbox and press 0 in the NDF section.
18. Check the quality of Retina 3D measurements (minimum 2 tests of the right and left eye).

## 10. Verification / power equalizer

Required tools: Scantest\_2, 1.5 Allen wrench, power meter, power measurement adapter

Supported devices: 155, 156, 190, 191, 192, 193, 194

**NOTE: When using the Scantest tool, do not look inside the lens. The laser beam can damage your eye (the only exception is when the scanners form a crosshair shape - the Exam task when you select START).**

Too high a power will affect the height of the spectrum, resulting in oversaturated scans. Below is an example of a situation where the power is too high relative to the height of the spectrum (in some cases, single thin vertical lines may appear).

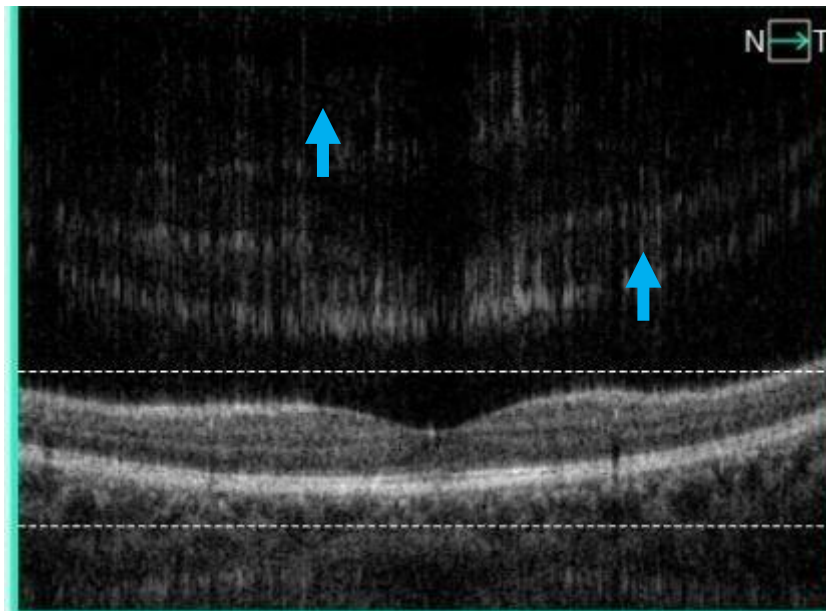

1. Power measurement should be done when the spectrum height is reduced or increased. Power adjustment should be done after changing the SLED.
2. Turn on the device.
3. To check the height of the spectrum, you can use the program Scantest\_It - it can be used by the end user under the guidance of a technician. (START menu of the operating system, all programs, SOCT, scantest\_It, [Connect]).

**It is not possible to measure the output power with scantest\_It, only the full diagnostic tool Scantest2 can be used for this purpose!!!**

**DON'T LOOK INTO THE FACILITY NOW!!!**

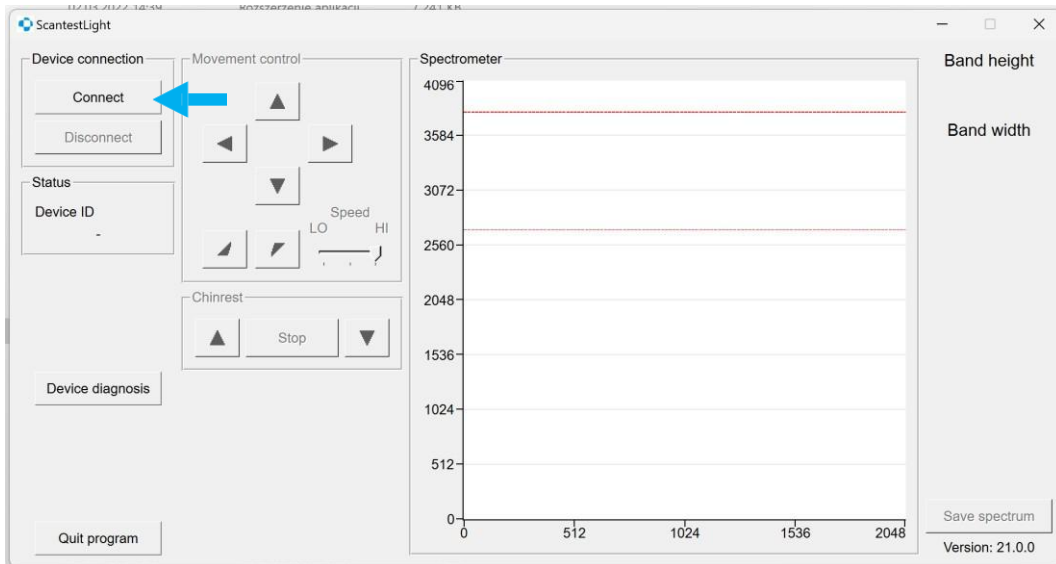

Scantest\_It is a basic diagnostic software for users to record the spectrum and test the device's head movement.



In **Scantest\_2** (Line sensor tab) read the height of the spectrum, pay no attention to other parameters besides the height.

4. To measure power, remove the front grille

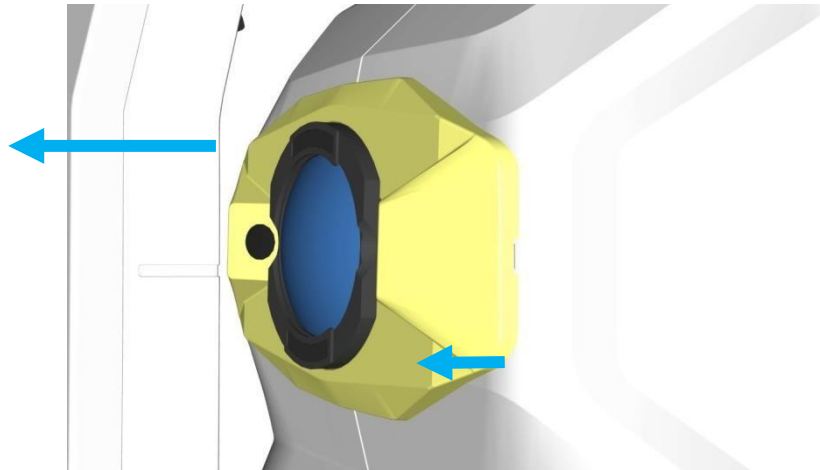

5. Mount the power measurement tool on the lens. Make sure the top of the tool fits into the positioning pin. Connect the power meter sensor to the tool and read the value on the power meter (**make sure to set  $\lambda=850$  nm**).



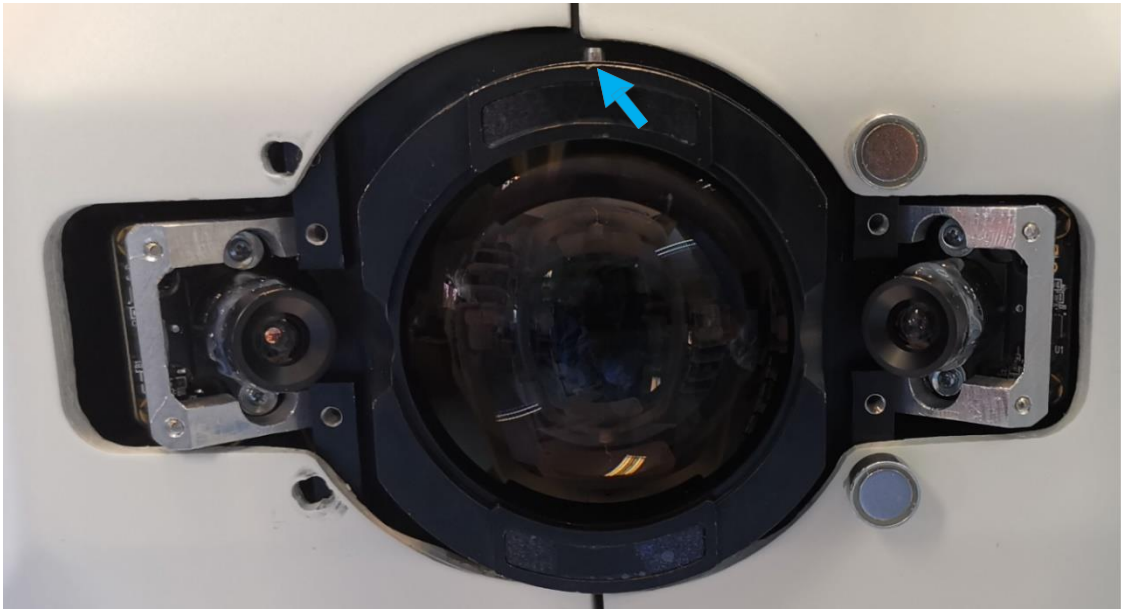

6. Start the Scantest2 tool and connect the device (select Start Task, then Start).
7. Open Toolbox and under the Power tab, check the OCT mirror checkbox (Not applicable to REVO 60/80/NX130 models).

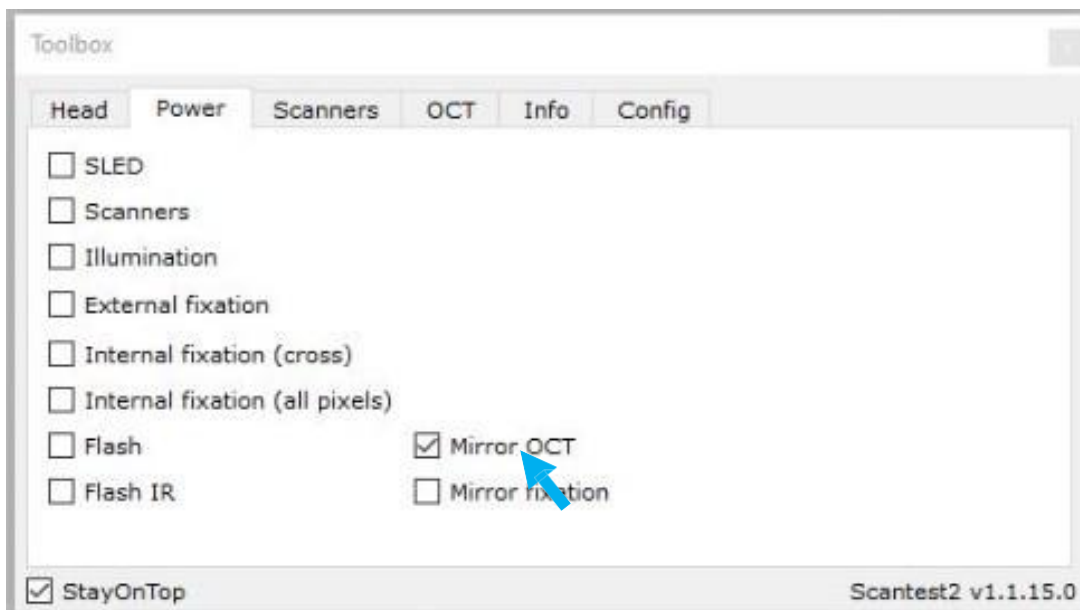

8. Go to the Line sensor tab with the [Next] button, press Start. Press the [Center Scanners] button. Then open the toolbox, go to the OCT tab and press Max, then press the "0" button under Focus OCT -D. Close the toolbox.

**CAUTION: Do not look into the lens now, because the laser light can damage your eye!!!**

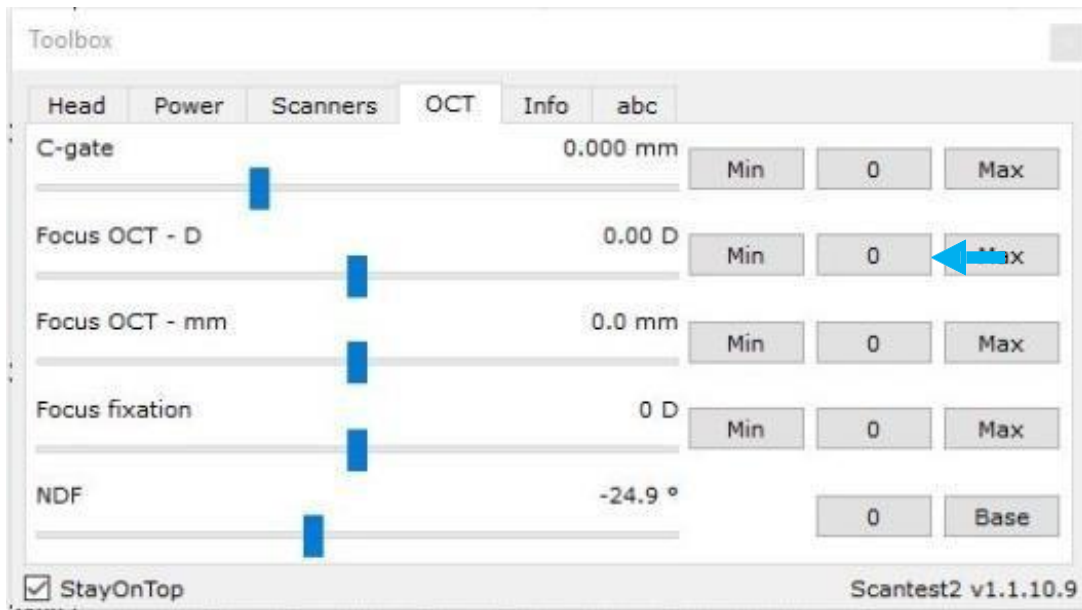

9. Read the value of the power meter (make sure the wavelength value is set to the correct value for the device. If the value is below or above the limit, adjust the power on the attenuator.



**OBJECTIVE LENS OUTPUT POWER & SPECTRUM height:**

Device type	Power	Spectrum	Wavelength
<b>SOCT REVO FC 190Xxxx (X&lt;5)</b>	1100 - 1250	2900 - 3300	830nm
<b>SOCT REVO FC 1905xxx</b>	1150 - 1250	2900 - 3300	850nm
<b>SOCT REVO FC130 1935xxx</b>	1500 - 1650	2700 - 3000	850nm
<b>SOCT REVO</b>	<b>60k</b>	1050 - 1150	2900 - 3400
<b>191xxxx</b>	<b>80k</b>	1150 - 1250	2900 - 3400
<b>SOCT REVO NX130 192xxxx</b>	1500 - 1650	2700 - 3000	850nm

10. The attenuator is located in the left front part of the device head.

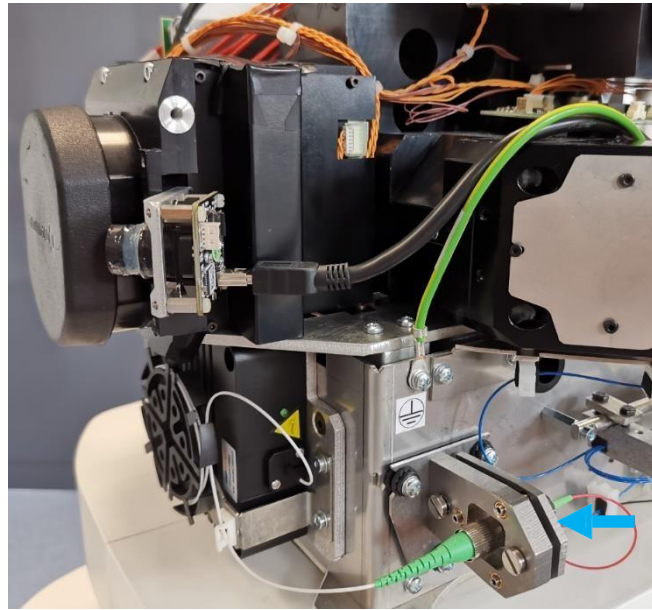

11. Use the 3 screws to set the appropriate power. Turn each screw about 3-8 degrees and observe the power meter reading. Gently bump the attenuator from the side to see if the power is stable.

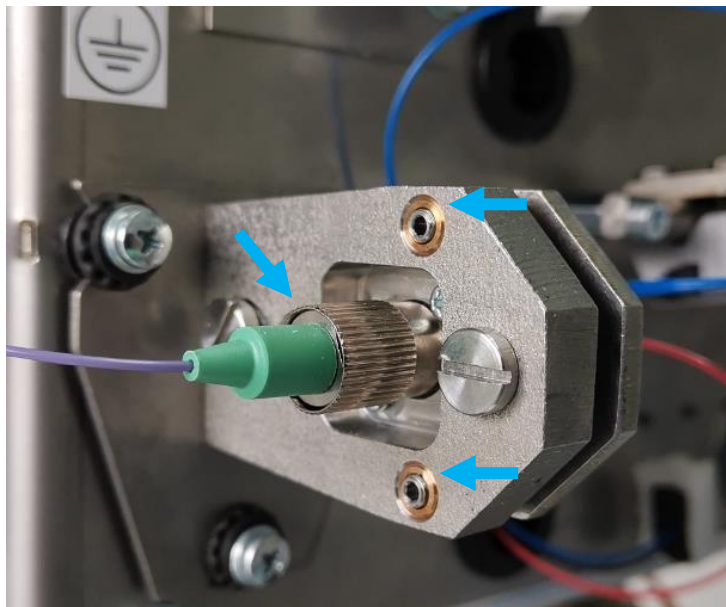

12. If the power has been set in the right range, check the pitch of the spectrum and adjust it if necessary by changing the NDF filter. To do this, follow the instructions in the next section.

13. Close the device and check its operation - conduct tests on the right and left eye.

# 11. Spectrum height verification/correction

Required tools: none

Supported devices: 155, 156, 190, 191, 192, 193, 194

A spectrum that is too high can be caused by too much output power, which will cause the scans to become oversaturated. Below is an example of a situation where the power/spectrum height is too high. First, check the power of the lens.

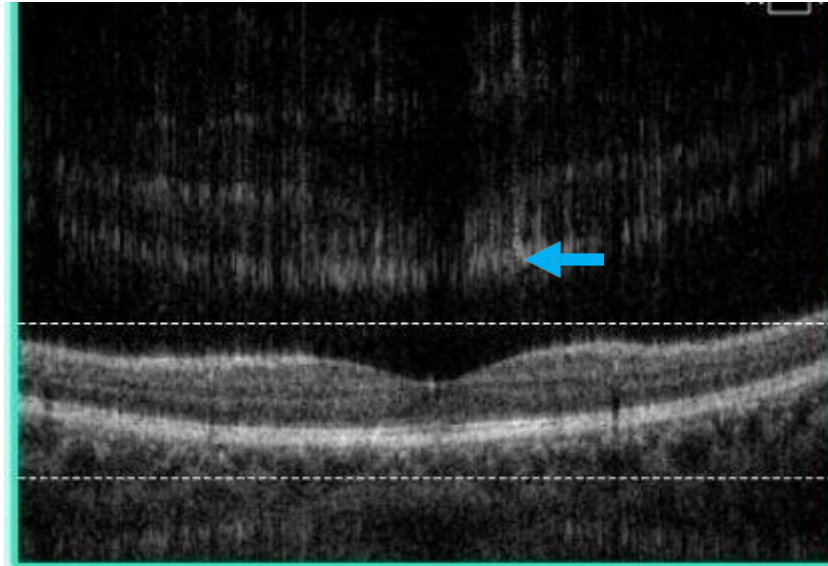

OBJECTIVE LENS OUTPUT POWER & SPECTRUM height:

Device type		Power	Spectrum	Wavelength
SOCT REVO FC 190Xxxx (X<5)		1100 - 1250	2900 - 3300	830nm
SOCT REVO FC 1905xxx		1150 - 1250	2900 - 3300	850nm
SOCT REVO FC130 1935xxx		1500 - 1650	2700 - 3000	850nm
SOCT REVO 191xxxx	60k	1050 - 1150	2900 - 3400	850nm
	80k	1150 - 1250	2900 - 3400	850nm
SOCT REVO NX130 192xxxx		1500 - 1650	2700 - 3000	850nm

1. To measure and correct the output power, see the section above.
2. If the **Scantest\_2** signal was too low and the power adjustment has already been checked/corrected, but the spectrum is still too high or too low, adjust it by following the procedure below.
3. Start the **Scantest\_2** tool, select the appropriate version of the device in the tab, Begin and press Start.

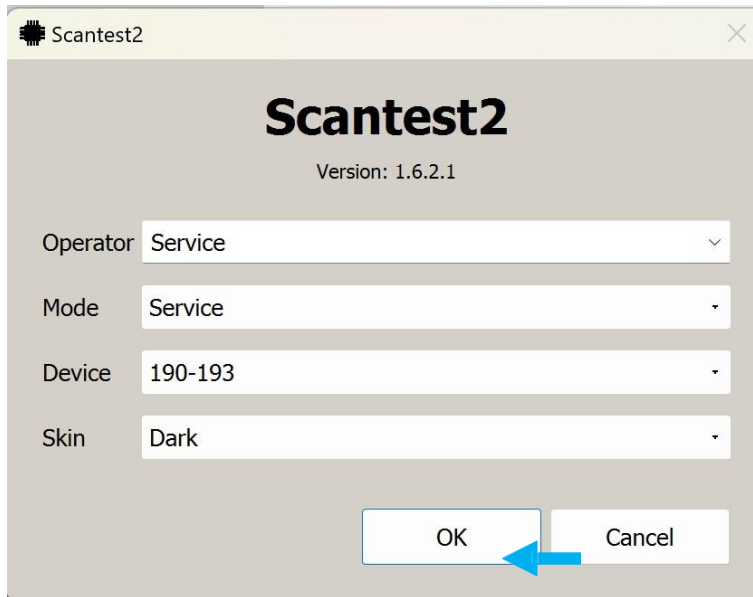

4. Use the [Next] button to go to the Line sensor tab and press the Start button.

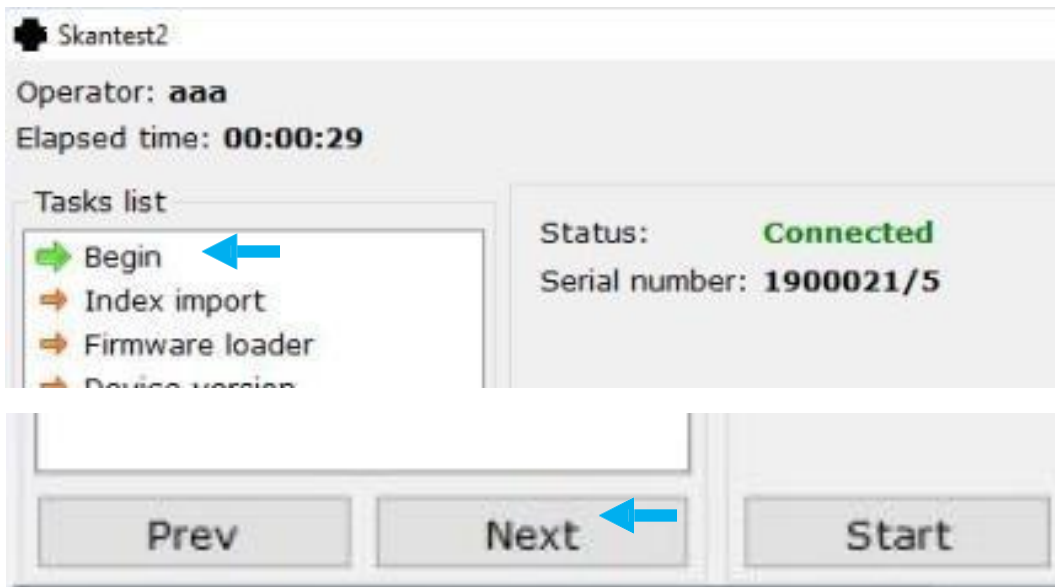

- Open the "Toolbox" tab, go to the "OCT" tab and move the NDF filter by moving the slider. At the same time, the height of the spectrum will change - find the best position around 3000. Make a note of the NDF value.

**NOTE:** In the case of the 155 and 156 device, spectrum correction is performed manually. You need to open the reference track, gently loosen one pressure screw of the NDF filter and then use your fingers to turn it while observing the height of the spectrum. If it reaches the correct height, secure the filter by tightening the clamping screw, and the reference track can be turned off.

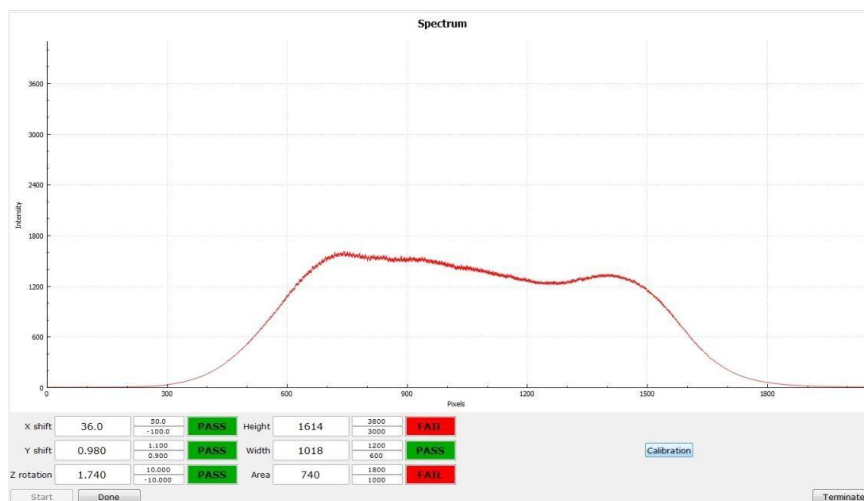
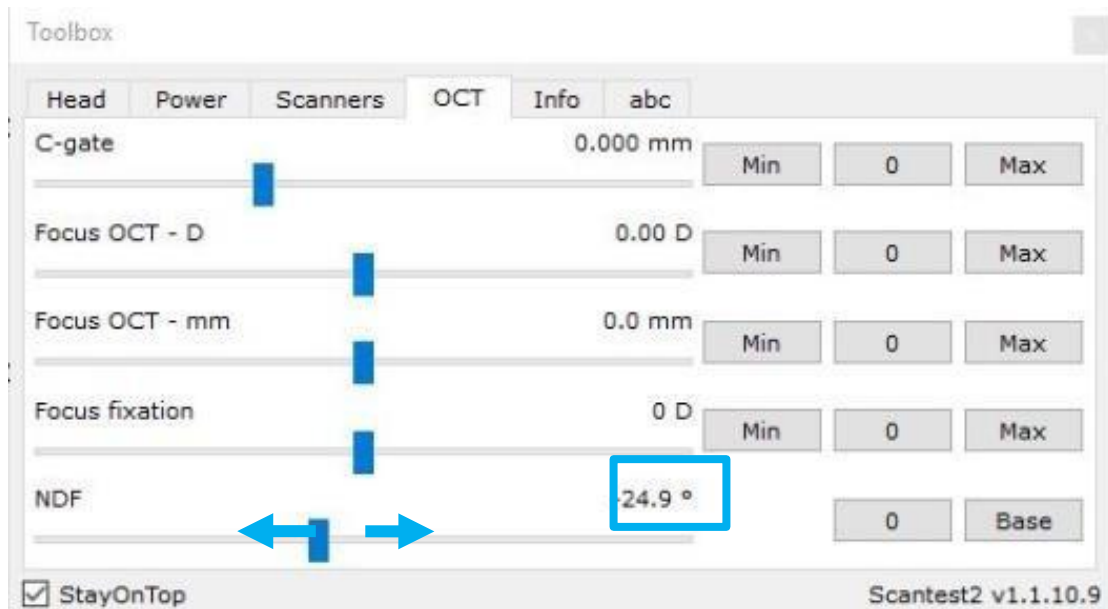

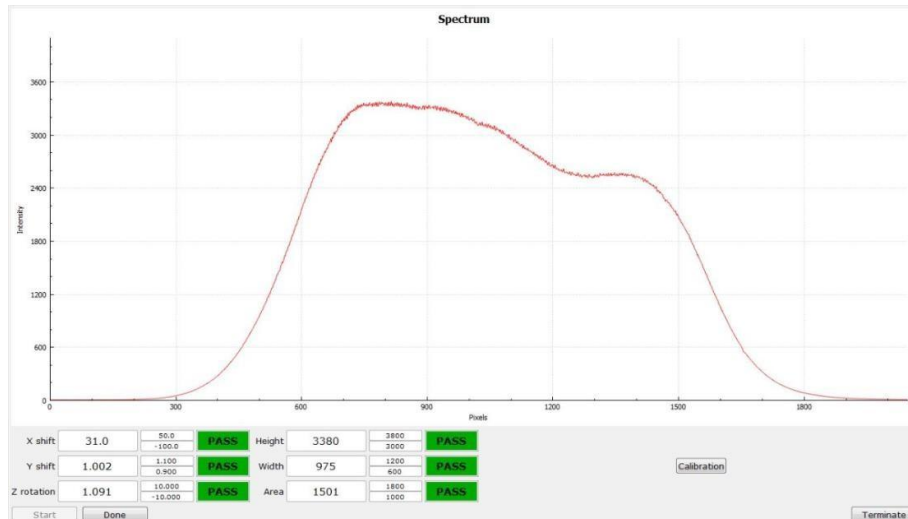

- After setting the appropriate NDF value, press the [Done] button, then use the [Next] button to move to the **Params** tab. Press [Start], [Save to file] to save the current parameters before making any changes.

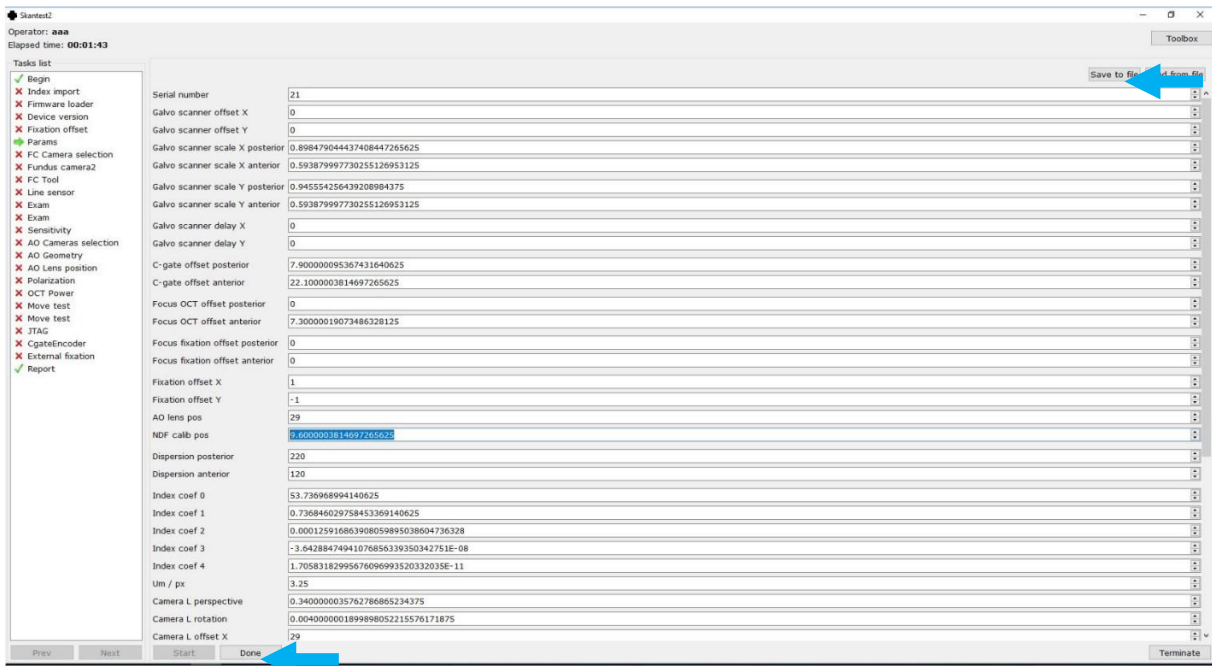

- Find the "NDF calb pos" line and enter the value that gave the correct spectrum height. If the value was negative, use the "-" sign to enter it. Values above zero should be entered as read in the toolbox, and a few digits after the decimal point will be filled in automatically.



- After entering the NDF value, press the [Done] button.
- Use the Next button to return to the Line sensor tab, press Start and check that the spectrum height matches the previous setting.
- Close **Scantest\_2**

## 12. Checking the chinrest bolt for tightness (behind the front cap) if the device has an aluminum chinrest

Tools required: Allen wrench

Supported devices: 155, 156, 190, 191, 192, 193, 194

On devices with an aluminum type of chinrest, check that the visible screw is tightened with a perceptible resistance. It holds the plastic collar of the chin lift mechanism in the correct position, And it prevents the plate from the position stop from destroying it.

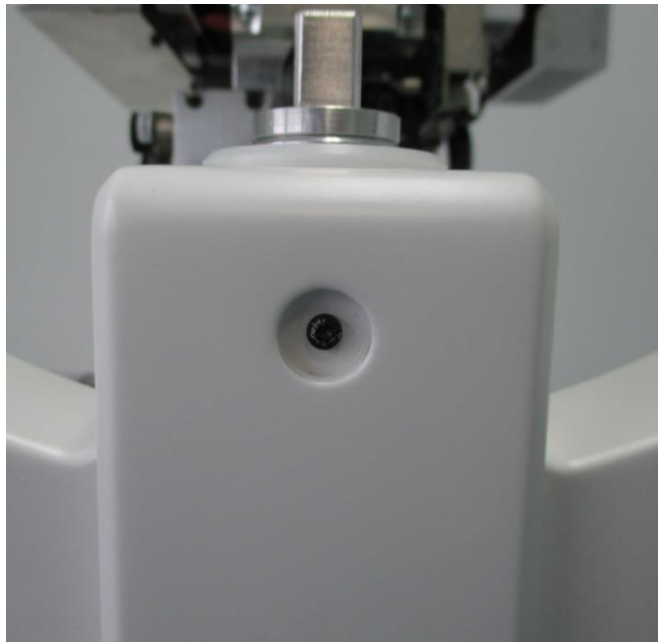

## 13. Checking the tightness of the heat sink- Applies only to 155xxx and 156xxx series devices

Required tools: Allen wrench Supported

devices: 155, 156

On the device turned off, check that the heat sink is mounted stably. On its other side are mounted scanner control boards, And at the moment when the heatsink is not stable, one of the boards of the heatsink may short circuit with the case, which may lead to damage to the electronics. That's why the test is performed on a switched-off device. If by moving it does not change its position, everything is ok. On the other hand, if it moves freely, you need to unscrew the heat sink, and screw more firmly the base, which is attached by two Allen screws behind it. In critical cases, replace the plastic bushings through which the two previously discussed screws pass.



# 14. Checking the alignment of the 19xxxx scanner bundles and correcting if necessary

Required tools: none

Supported devices: 190, 191, 192, 193, 194

The SCANST-EW-04A5 wiring harnesses running from the galvoskaner HAN controllers to the motors should be routed as shown in the photos below. It is important that the wires coming out of the plugs connected to the motors are not kinked. The X motor cable should be routed so that it does not touch the controller's heat sink or its bracket. Clamps must not be too tight, as they can cut the cable insulation.

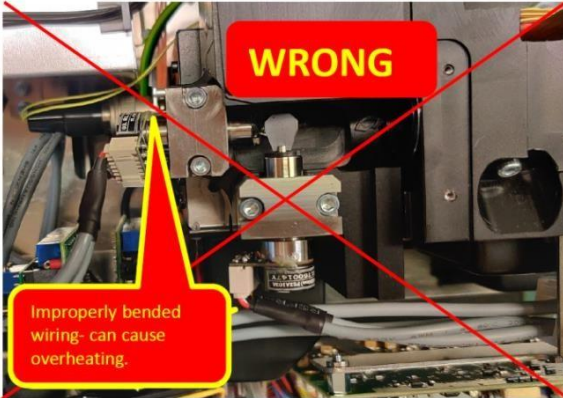
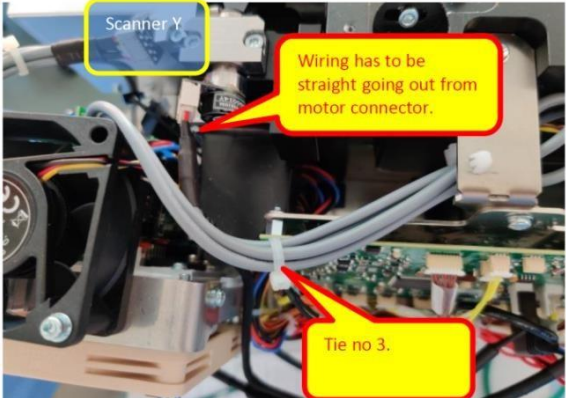
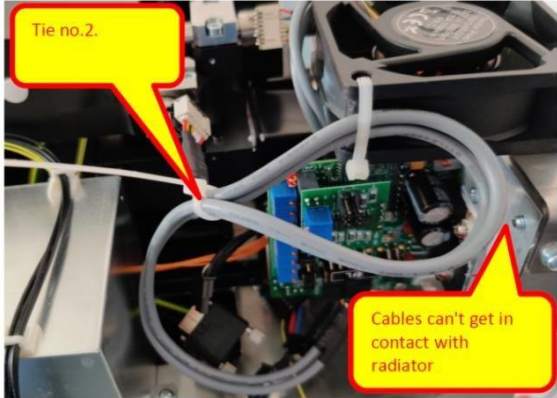
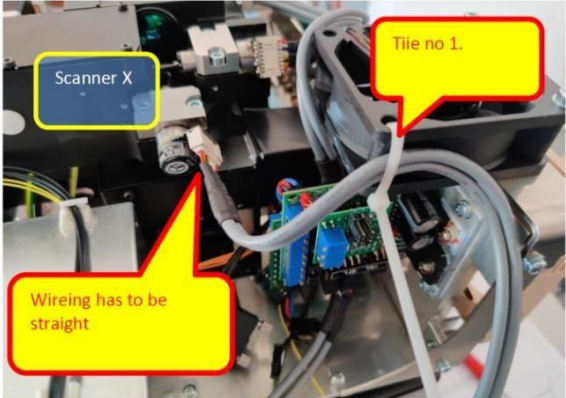

**NOTE:** Improper operation of galvoscaners (crackling, squeaking) can be caused by damage to the wiring harnesses leading to the motors. If you move the wires coming out of the motors' plugs during the operation of the scanners and hear interference in their operation, it is imperative to replace such harnesses with working ones.

## 15. Calibration of biometrics and topography modules ( if applicable )

Tools required: 155-4550 (aluminum chin) ;190-4550 (plastic chin) Supported devices: 155, 156, 190, 191, 192, 193, 194

Devices that have an unlocked biometrics module in the basic version should periodically undergo a calibration test. Part of the periodic technical inspection should be calibration of the biometrics module toolern.

If the customer has a topography module, biometrics version with IOL, and has its own tool, either single or combo version, check:

- Is the tool not damaged, fouled
- Does the calibration pass on this tool without problems
- Device 155/156 whether the anterior adapter is not damaged, dirty, whether it is not loose when mounted on the lens ( if it is loose, note the need to replace the adapter, or the sleeve itself in this adapter )

NOTE: The topography calibration standard comes in three color versions

- Gray
- Black
- White

If the customer has a gray pattern, it is recommended to replace the pattern free of charge.

## 16. Final device check - FQC Scantest\_2 task

According to the task in Skantest\_2 "Final inspection", it is necessary to carry out a final inspection of the device in order to obtain a final report confirming the efficiency of the device.

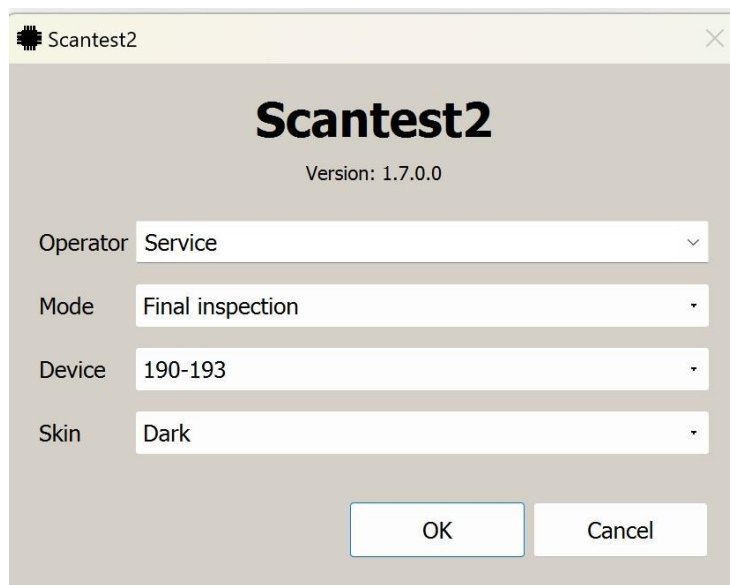

The screenshot shows a software window titled "Scantest2" with a close button in the top right corner. The window displays the title "Scantest2" and the version "Version: 1.7.0.0". Below this, there are four dropdown menus for configuration:

- Operator: Service
- Mode: Final inspection
- Device: 190-193
- Skin: Dark

At the bottom of the window, there are two buttons: "OK" and "Cancel".



operator has entered a compatible serial number and optics version of the device then the task has a status of PASS, otherwise FAIL. To prevent the serial number and optics version from being read from the labels at the top of the main window, they are hidden for the duration of this task. The list of displayed parameters varies depending on the type of connected device, e.g. for 191/192 devices the parameters for the camera fundus are not displayed.

## 16.3. Device status task

Required tools: none

Supported devices: 190, 191, 192, 193, 194

The task is used to read the status of the device to diagnose potential damage.

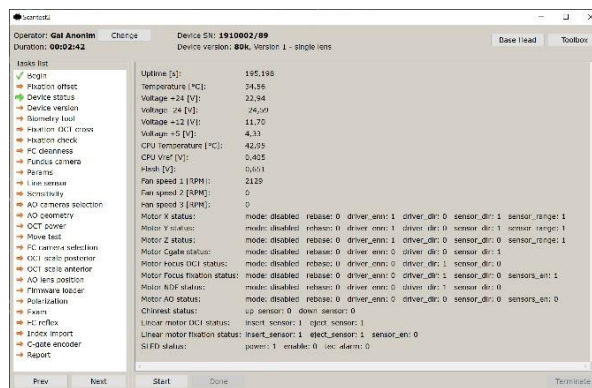

This task does not allow modification of any parameter of the device, it is only used to read the current status. After starting the task, a number of parameters are displayed which are then refreshed cyclically several times per second. The parameters displayed are:

- Uptime - the time in seconds that has elapsed since the device started up
- Temperature - the temperature of the device as measured by a sensor mounted on the CPU board
- Voltage +24 - measured value of supply voltage +24V
- Voltage -24 - measured value of supply voltage -24V
- Voltage +12 - measured value of 12V supply voltage
- Voltage +5 - measured value of supply voltage 5V
- CPU Temperature - temperature of the microcontroller
- CPU Vref - the value of the microcontroller reference voltage
- Flash - state of charge of Flash capacitors
- Fan speed 1 - the number of revolutions per minute of the fan connected to connector 1
- Fan speed 2 - the number of revolutions per minute of the fan connected to connector 2
- Fan speed 3 - the number of revolutions per minute of the fan connected to connector 3
- Motor X status - operating status of motor X
  - mode - mode of operation - base / move / disabled

- rebase - if 1 it means that the engine probably lost the steps and redetermined the value of zero when passing through the baseline
- driver\_enn - state of the ENN line of the stepper motor driver
- driver\_dir - state of the DIR line of the stepper motor driver
- sensor\_dir - state of baseline determining zero position
- sensor\_range - state of baseline limiting range of motion
- Motor Y status - operating status of motor Y, description of fields as above.
- Motor Z status - operating status of motor Z, description of fields as above.
- Motor Cgate status - operating status of the motor Cgate, description of fields as above.
- Motor Focus OCT status - operating status of motor focus OCT, description of fields as above.
- Motor Focus fixation status - operation status of the motor focus fixation, description of the fields as above.
- Motor NDF status - operating status of the motor NDF, description of fields as above.
- Motor AO status - operation status of anterior lens motor, description of fields as above.
- Chinrest status - the status of the chin basalts, upper and lower, respectively
- Linear motor OCT status - baseline status of the linear motor OCT
- Linear motor fixation status - baseline fixation motor baseline status and baseline fixation engagement status
- SLED status - status of the SLED LED
  - power - if 1 then SLED power is on
  - enable - if 1 then SLED diode is enabled
  - tec\_alarm - if 1 then the diode reports the TEC module alarm

The condition of some baseplates, especially linear motors and the AO motor, may not be correct because they are powered only when the motor in question is moving.

## 16.4. Line sensor task

Required tools: Power meter, power meter adapter Supported devices:

155, 156, 190, 191, 192, 193, 194

This task allows you to display the spectrum of the OCT signal.

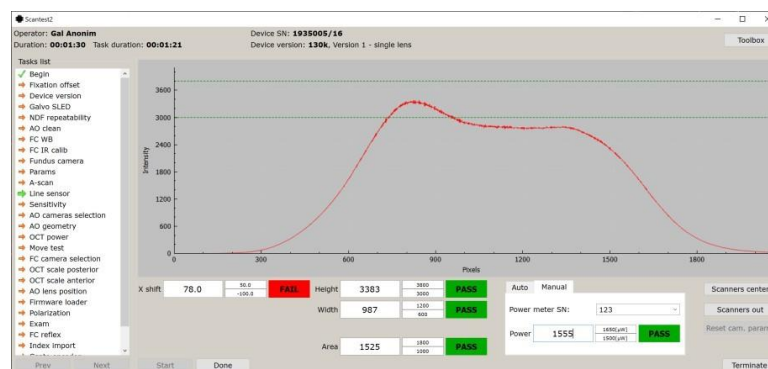

After starting the task with the Start button, the spectrum of the OCT signal read from the spectrometer's camera is displayed on the graph, in addition, the interval in which the spectrum should measure is displayed. In addition, the following parameters are measured:

- X shift - shift of the spectrum in the horizontal axis of the camera
- Y shift - shift of the spectrum in the vertical axis of the camera (only for devices 155 with Aviiva camera)
- Z rotation - twisting of the spectrum in the Z axis of the camera (only for devices 155 with Aviiva camera)
- Height - the height of the spectrum
- Width - half-width of the spectrum
- Area - area under the spectrum graph

Additional functions in this task here:

- Power measurement on the lens in automatic mode (Power Meter connection required) or in manual mode
- Save to file option in the context menu on the chart - allows you to save the spectrum to a file
- Log switch in the context menu on the graph - allows you to display the spectrum on a logarithmic scale
- Idx switch in the context menu on the chart - allows you to display the spectrum after reindexing
- Scanners center button - allows you to center the position of galvo scanners for power measurement, then the height of the spectrum is not counted
- Scanners out button - setting the position of galvo scanners out of the lens for correct measurement of spectrum height
- Reset cam. params button - allows you to reset the camera settings to default values (option available only for Aviiva cameras on 155 devices)

The task ends with the Done button and no parameters are saved in the device configuration after completion.

Name of the task in the XML file: line\_sensor

Parameters to be defined in the XML file:

- x\_shift - permissible range of the X shift parameter
- y\_shift - the permissible range of the Y shift parameter
- z\_rotation - the permissible range of the Z rotation parameter
- height - the permissible range of the Height parameter
- width - permissible range of Width parameter
- area - permissible range of the Area parameter
- power - permissible range of the power parameter
- meter\_sn - serial number of the power meter
- hide\_power\_measure - when this parameter is added, the power measurement function is hidden

## 16.5. Move test task

Required tools: none

Supported devices: 155, 156, 190, 191, 192, 193, 194 The task is used to test various modules of the device.

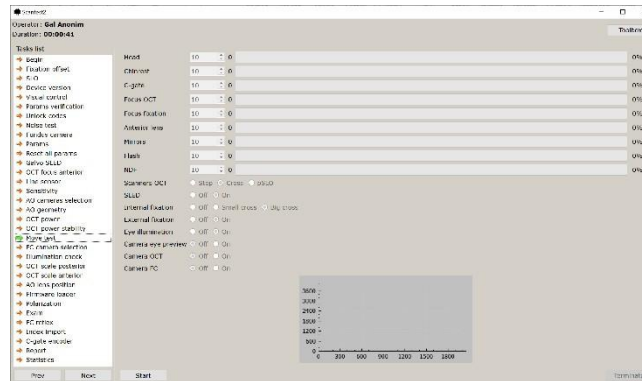

You can perform the test of the following modules:

- Head - passage of the device head in X, Y and Z axes
- Chinrest - chin ride up - down
- Spectrometer - drive of spectrometer motors (only 155 devices with Aviiva camera)
- Cgate - engine run in the reference track
- Focus OCT - a run of the focus engine in the OCT circuit
- Focus fixation - the passage of the focus motor in the fixation track
- Anterior lens - passage of anterior lens motor (only in 19x devices)
- Mirrors - slide OCT and fixation mirrors in and out (only on 190, 193 and 194)
- Flash - triggers flash (only on 190, 193 and 194 devices)
- NDF - passage of the NDF filter motor (only on 19x devices)

In addition, it is possible to run additional modules when performing a motion test of the above modules.

- galvo OCT scanners - if enabled, they can operate in two modes - Cross (quick preview mode) and pSLO (pSLO preview mode, available only on 155, 156, 190-194 devices)
- SLED - SLED LED illumination
- Internal fixation - display of internal fixation
- External fixation - external fixation illumination
- Eye illumination
- Camera eye preview - cameras for eye preview, camera image is displayed at the bottom of the window
- Camera OCT - OCT camera, the read spectrum from the camera is displayed in the graph at the bottom of the window

- Camera FC - FC camera, the camera image is displayed at the bottom of the window (devices 190, 193 and 194 only)

The number of repetitions of movement of each module can be defined in the XML file, by default each value is set to zero which means that the module will not be tested.

Once all the runs are completed, the task ends automatically. This task does not modify any parameters in the device configuration.

Name of the task in the XML file: `move_test`

Parameters to be defined in the XML file:

- `repeat_head` - number of repetitions of the head module passage
- `repeat_chinrest` - number of repetitions of the Chinrest module ride
- `repeat_spectrometer` - number of repetitions of the Spectrometer module pass
- `repeat_cgate` - number of repetitions of the Cgate module passage
- `repeat_focus_oct` - number of repetitions of the Focus OCT module passage
- `repeat_focus_fix` - number of repetitions of the Focus fixation module passage
- `repeat_focus_ld` - number of repetitions of the Focus LD module pass
- `repeat_focus_cam` - number of repetitions of the Focus cam module passage
- `repeat_anterior_lens` - number of repetitions of the Anterior lens module passage
- `repeat_mirrors` - number of repetitions of OCT mirror insertion/extraction and fixation
- `repeat_flash` - number of flash triggers
- `repeat_filter_oct_icg` - number of repetitions of OCT/ICG filter pass
- `repeat_filter_slo` - number of repetitions of SLO filter passes
- `repeat_ndf` - number of repetitions of the NDF filter pass
- `scanners` - galvo scanners mode (0= scanners stopped, 1= cross mode, 2= pSLO mode)
- `sled` - SLED LED on (0= LED off, 1= LED on)
- `fix_int` - internal fixation (0= off, 1= small cross, 2= large cross)
- `fix_ext` - external fixation (0= disabled, 1= enabled)
- `illumination` - eye illumination (0= off, 1= on)
- `camera_ep` - eye view cameras (0= off, 1= on)
- `camera_oct` - OCT camera (0= disabled, 1= enabled)
- `camera_fc` - FC camera (0= disabled, 1= enabled)
- `speed_head_x` - head travel speed in the X axis
- `speed_head_y` - head travel speed in Y axis
- `speed_head_z` - head travel speed in Z axis
- `delay_head` - delay between successive head passes
- `delay_mirrors` - delay between successive insertions/extensions of mirrors

- delay\_flash - delay between successive flash triggers

## 16.6. C-gate Encoder task

Required tools: none

Supported devices: 190, 191, 192, 193, 194

This task is used to check the operation of the encoder in the reference track on 19x devices. When the Start button is pressed, the reference mirror is moved to the beginning of the travel range and then slowly to the end of the range. During this travel, the task position (green), the position read from the motor steps (red) and the position read in the encoder (blue) are read. All these values are displayed on a graph as a function of the mirror position. In addition, an error graph (magenta color) between the task position and the position read from the encoder is displayed, multiplied by 100 to make minor deviations visible.

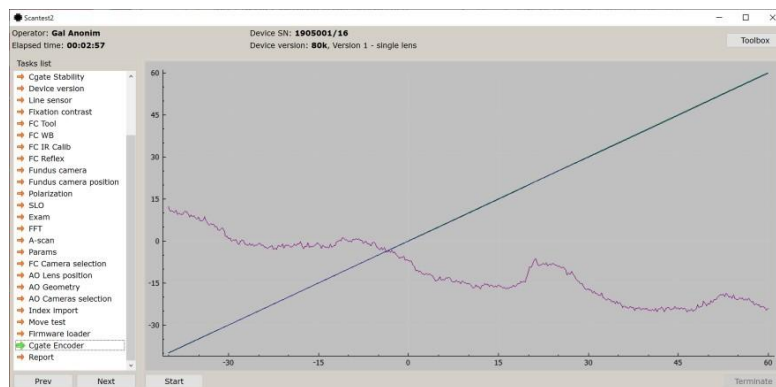

When the mirror reaches the end of the range, the task ends automatically.

## 16.7. C-gate Stability task

Required tools: none

Supported devices: 155, 156, 190, 191, 192, 193, 194

This task is used to check the stability of the reference track as a function of the position of the mirror in the track. When the Start button is pressed, the mirror is moved to the start position (-40 mm) and the spectrum of the signal returning from the reference track is displayed on the first graph. After a while, the movement of the mirror up to the final position (78 mm) is started, and during this movement the signal spectrum is continuously displayed, as well as its height as a function of the position of the mirror on the second graph.

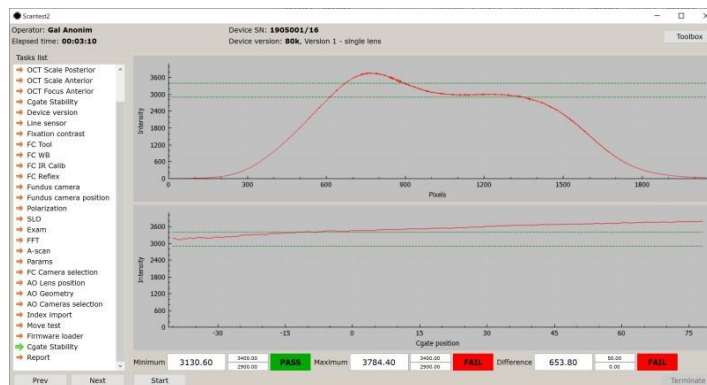

When the mirror reaches the final position, then the task ends automatically. Three parameters are displayed below the graphs, which are checked during the mirror's passage:

- Minimum - minimum spectrum height (value depends on the connected device)
- Maximum - maximum spectrum height (value depends on the connected device)
- Difference - the difference between the maximum and minimum recorded spectrum height (the default acceptable range is 0 to 50)

Name of the task in the XML file: cgate\_stability

Parameters to be defined in the XML file:

- height - acceptable range of spectrum height (minimum and maximum)
- diff - permissible difference between maximum and minimum spectrum height

## 16.8. Galvo SLED task

Required tools: none

Supported devices: 155, 156, 190, 191, 192, 193, 194

The task is long to check that the SLED LED does not turn off in different positions galvo scanners.

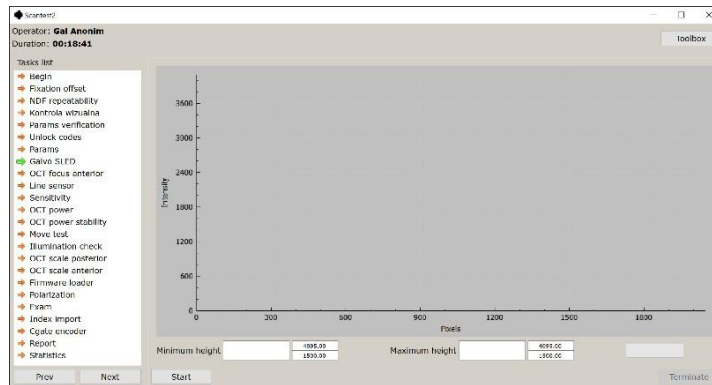

After starting the task with the Start button, the spectrum of the OCT signal is displayed on the graph and the height of this spectrum is measured. The galvo scanners are then moved from one extreme position (default -10V) to the other extreme position (default 10V) with a preset step (default 0.25V). While the galvo scanners are stationary at each position, the spectral height is measured and the parameters recording the minimum and maximum spectral heights are updated accordingly. The progress of the entire task is presented on the progress bar. The task ends automatically when the spectrum height is verified over the entire range. This task does not modify any parameters in the device configuration.

Name of the task in the XML file: galvo\_sled

Parameters to be defined in the XML file:

- height - permissible range of spectrum height
- range - range of galvo scanner movement in which the measurement is made
- step - the step with which the measurement is performed
- delay - the time in milliseconds that is waited after each adjustment of the scanners position

## 16.9. NDF repeatability task

Required tools: none

Supported devices: 190, 191, 192, 193, 194

The task is used to check whether the NDF filter sets repetitively in the set position.

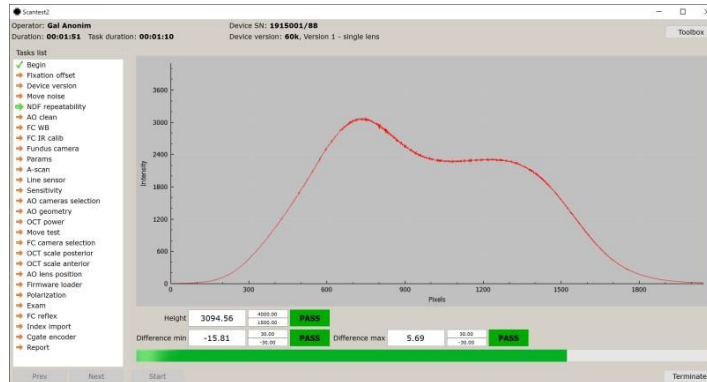

After starting the job with the Start button, the NDF filter is set to the base (calibrated) position. The reference spectrum height that is expected with such a filter setting is read. Then the specified number of cycles (default 10) of setting the filter to one extreme position and the other extreme position and returning to the base position is performed. After each return to the base position, the spectrum height is read and the deviation from the reference height is counted. The maximum deviation to plus and minus is displayed in the corresponding windows. The task ends automatically after the specified number of cycles.

Name of task in XML file: ndf\_repeat

Parameters to be defined in XML file:

- diff - permissible deviation of spectrum height from the reference value
- count - number of test cycles

## 16.10. FC Cleanness task

Tools required:None Supported

devices:190, 193, 194

This task is used to check the cleanliness of the optics in the video path of the camera fundus in devices 190, 193 and 194. It is possible to start IR preview and take a picture in four configurations:

- with both mirrors (fixation and OCT) extended and Anterior lens extended
- With both mirrors (fixation and OCT) extended and the Anterior lens retracted
- with the fixation mirror retracted and the OCT extended and the Anterior lens extended
- With OCT mirror retracted and fixation extended and Anterior lens extended

In each configuration, the operator evaluates the cleanliness of the image, if any impurities are visible then remove them and take the picture again.

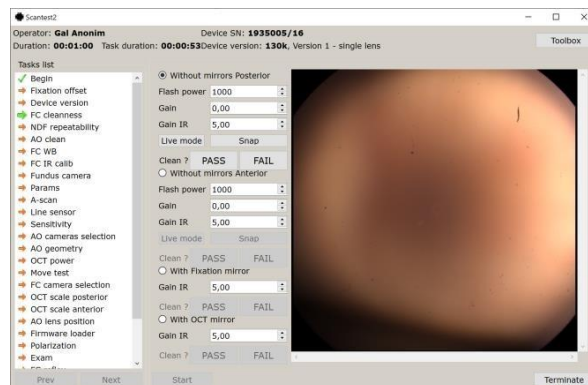

For the first two configurations (without both mirrors), it is possible to set the following parameters

- flash power
- camera enhancement for the photo
- camera gain for IR

In these two configurations, you can display both IR preview and take a photo. For the latter two configurations, on the other hand, it is only possible to start IR preview and so only camera gain for IR mode is available in the list of parameters to modify.

When all four PASS/FAIL buttons are selected, the task ends automatically. This task does not modify any parameters in the device configuration.

## 16.11. Report task

Required tools: none

Supported devices: 155, 156, 190, 191, 192, 193, 194

The task is used to generate two PDF reports of completed tasks. One full for digital documentation, the other without some previews for printing with the annotation \*\_print.pdf

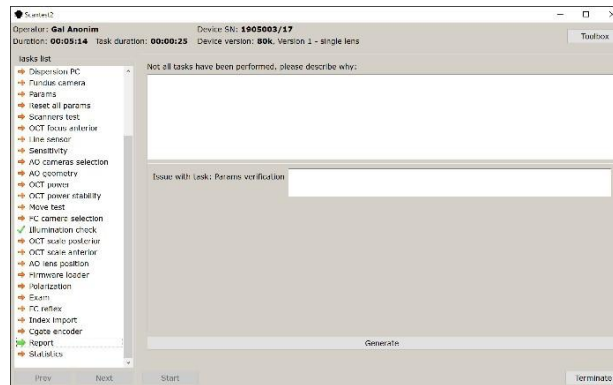

This task should be at the end of the task list. After starting a task with the Start button, a window is displayed with an opportunity to enter a comment. If at least one task from the task list has been skipped, then a comment is mandatory. In addition, if there are tasks with FAIL status then below the comment box a list of FAILs is displayed with the possibility to enter a comment for each of them. After entering comments, you can generate a PDF report by clicking on the Generate button. After the report is generated, a link to the generated file is displayed. This task does not modify any parameters in the device's configuration memory.

## 17. Final check of test quality

After all service activities, check the quality of the tests. This provides a reference to the tests performed at the beginning. After that, it is recommended that the selected initial report and the final report along with the test reports be ripped to an external drive, printed this, and attached to the work card.

## 18. List of required tools for technical review

Revo 155xxx ; 156xxx

- Portable drive
- Scantest\_2
- Calibrated power meter with calibrated measuring head
- Artificial eye 155
- Measuring head adapter 155
- Checkerboard 155
- Topo/bio calibration tool 155-4550 Revo

19xxx

- Portable drive
- Scantest\_2
- Calibrated power meter with calibrated measuring head
- Artificial eye 190
- Measuring head adapter 190
- Checkerboard 190
- Chessboard 191
- Topo/bio calibration tool 190-4550 Tools:
- PH1 screwdriver
- Allen wrench set
- Wrench 5.5
- KG 1
- Cleaning papers
- Bamboo stick
- Flashlight
- Compressed air
- Cutters
- Clamps