



## **PE175BFA** **CERMAX® XENON SHORT-ARC LAMPS**



*Cermax® Xenon short-arc lamps from Excelitas Technologies are ideal for applications that require a high degree of illumination control.*

The Cermax® Xenon short-arc lamp from Excelitas Technologies is an innovative lamp design in the specialty lighting industry. Cermax® Xenon lamps were first introduced in the early 1980s and are now used in diagnostic and surgical endoscopes in most major hospitals worldwide, in high-brightness projection display systems, and for a wide variety of other high-performance applications.

The Cermax® Xenon lamp, Model PE175BFA, has an integrated parabolic reflector, enabling high-intensity, focused output of visible and infrared radiation. With their internal reflector and rugged ceramic body construction, Cermax® Xenon lamps are the safest and most compact alternative to conventional quartz xenon lamps. This makes them ideal for applications that require a high degree of illumination control.

Current-regulated or power-regulated power supplies with output ripples of less than 5% are recommended. Single-shot ignition pulses are advised because radio frequency starters may damage the lamp's internal reflector.

In addition to lamps, Excelitas Technologies manufactures Cermax® Xenon short-arc lamp power supplies, lamp holders, OEM lighting systems, and fiber optic light sources.

**CERMAX**

### **Key Features**

- High-intensity illumination—2200 Lumens
- Power range of 150-200 Watts
- 1000 hours life
- Broad spectral range with 5900° Kelvin color temperature
- Made in the U.S.A.

### **Applications**

- Medical and industrial fiber optic illuminators
- Machine vision
- Infrared and visible spotlights/beacons
- Spectroscopy
- Microscopy
- UV Curing
- Video projection
- Solar simulation
- Wafer Inspection

## PE175BFA

# CERMAX® XENON SHORT-ARC LAMPS

## PE175BFA

Operational Specifications		
Description	Nominal	Range
Power	175 Watts	150-200 Watts
Current	14 amps (DC)	12-16 amps (DC)
Operating Voltage	12.5 volts (DC)	11-14 volts (DC)
Ignition Voltage	23-35 kilovolts (system dependent)	
Temperature	150° C (Maximum)	
Lifetime*	1000 hours typical	

\* End of life is defined as 50% of initial output

Initial Output at Nominal Power	
F= UV Filtered Output	
Description	PE175BFA
Peak Intensity	350x10 <sup>3</sup> Candelas
Radiant Output*	25 Watts
UV Output*	1.2 Watts
IR Output*	14 Watts
Visible Output*	2200 Lumens
Color Temperature	5900° Kelvin
Peak Instabilities	4%
Beam Geometry**	5°/6°/7°

\* These values indicate total output in all directions. Wavelengths = UV<390 nm, IR>770 nm, Visible: 390 nm-770 nm

\*\* Beam Geometry defined as the half angle at 10% PTS after 0/100/1000 hours

Physical Specifications	
Description	Specification
Weight	131 grams
Window Diameter	1.0 inch (25.4 mm)
Country of Origin	United States of America

## PE175BFA

# CERMAX® XENON SHORT-ARC LAMPS

## PE175BF

### Focused Output with a f/1.0 Lens

Description	Visible Output	Total Output*
3 mm aperture	830 Lumens	8 Watts
6 mm aperture	1400 Lumens	13 Watts

\* Nominal values at 175 Watts after 2 hour burn-in.

### NOTES:

1. Lamp must not be operated with window facing upwards within 45° of vertical.
2. Seal temperature must not exceed 150° C.
3. Current/power regulated power supplies and Excelitas lamp housing units are recommended.
4. Lamp must be operated within recommended current and power range. Over powering may lead to arc instability, hard starting and premature aging.
5. Hot mirror assembly is available for IR filtering.
6. Cermax® Xenon lamps are much safer lamps to use than their quartz xenon arc lamp equivalents. However, caution must be practiced when operating lamps because they are under high pressure, require high voltage, reach temperatures up to 200° C, and their IR and UV radiation can cause skin burns and eye damage. Please read the Hazard Sheet included with each lamp shipment.

## Mechanical Dimensions

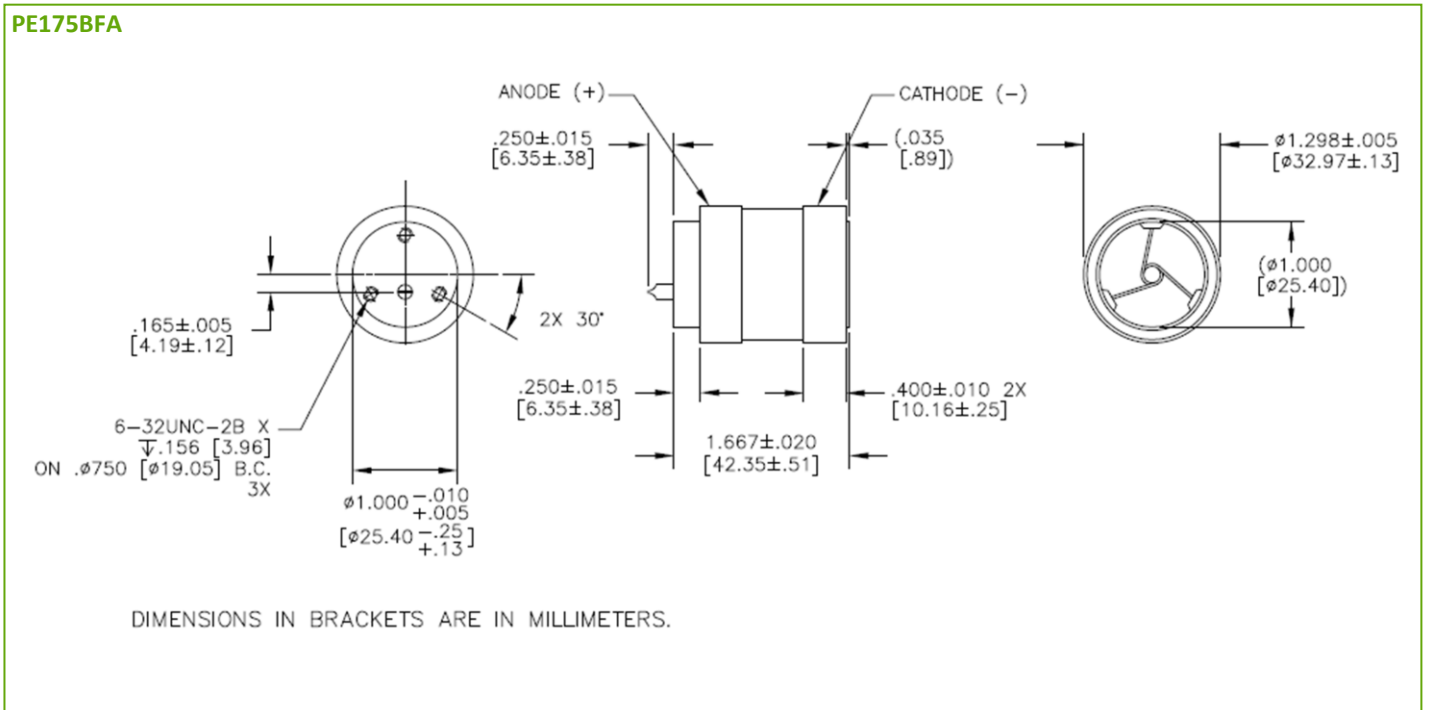

PE175BFA

## CERMAX® XENON SHORT-ARC LAMPS

### Spectral Output

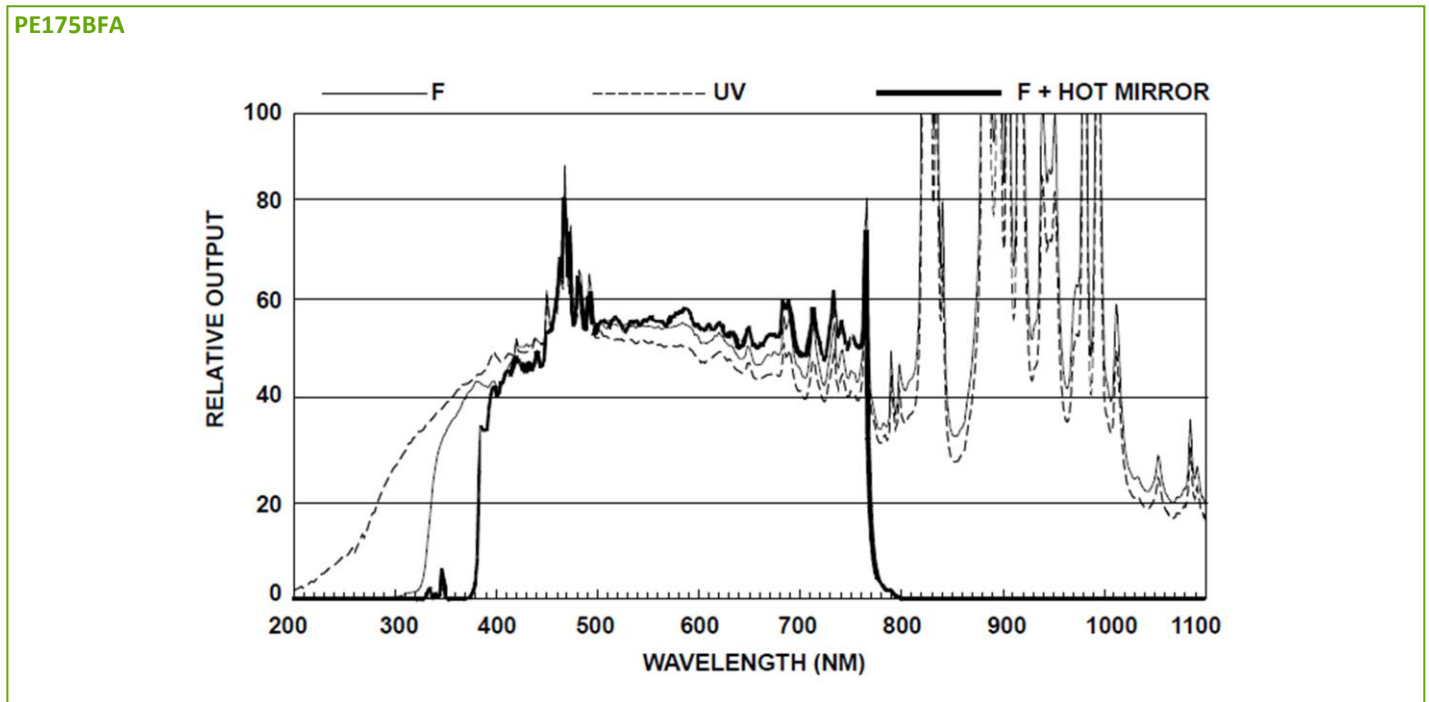

### About Excelitas Technologies

Excelitas Technologies is a global technology leader focused on delivering innovative, customized solutions to meet the lighting, detection and other high-performance technology needs of OEM customers.

From medical lighting to analytical instrumentation, clinical diagnostics, industrial, safety and security, and aerospace and defense applications, Excelitas Technologies is committed to enabling our customers' success in their specialty end-markets. Excelitas Technologies has approximately 3,000 employees in North America, Europe and Asia, serving customers across the world.

**Excelitas Technologies  
Illumination, Inc.**  
44370 Christy Street  
Fremont, California  
94538-3180 USA  
Telephone: (+1) 510.979.6500  
Toll-free: (+1) 800.775.6786  
Fax: (+1) 510.687.1140  
shortarcxenon.na@excelitas.com

**Excelitas Technologies Singapore,  
Private Limited.**  
47 Ayer Rajah Crescent #06-12  
Singapore 139947  
Telephone: (+65) 6775 2022 (Main Line)  
Telephone: (+65) 6770 4366  
(Customer Service Hotline)  
Fax: (+65) 6778 1752  
shortarcxenon.asia@excelitas.com

**Excelitas Technologies  
GmbH & Co. KG**  
Wenzel-Jaksch-Str. 31  
D-65199 Wiesbaden  
Germany  
Telephone: (+49) 611 492 430  
Fax: (+49) 611 492 165  
shortarcxenon.europe@excelitas.com

**Japan  
Excelitas Technologies**  
East Tower 4th Floor,  
Otemachi First Square  
1-5-1 Otemachi, Chiyoda-ku,  
Tokyo 100-0004  
Telephone: (+81) 3-5219-1228  
Fax: (+81) 3-5219-1201  
shortarcxenon.asia@excelitas.com

For a complete listing of our global offices, visit [www.excelitas.com/locations](http://www.excelitas.com/locations)

© 2012 Excelitas Technologies Corp. All rights reserved. The Excelitas logo and design are registered trademarks of Excelitas Technologies Corp. All other trademarks not owned by Excelitas Technologies or its subsidiaries that are depicted herein are the property of their respective owners. Excelitas reserves the right to change this document at any time without notice and disclaims liability for editorial, pictorial or typographical errors.

**EXCELITAS**  
TECHNOLOGIES