

From Eye to Insight



LEICA DM1000 – 3000

Ergonomic System Microscopes



MICROSCOPY TAILORED TO YOU!

DESIGNED TO ADAPT TO AN INDIVIDUAL USER'S DAILY ROUTINE

Leica Microsystems has turned innovative ideas into reality by creating a microscope that seamlessly adapts to the physique and workflow of every user. With the Leica DM1000-3000 Series, work at the microscope is not only efficient, but also comfortable.

Leica DM1000-3000 Microscopes are completely adjustable. With just a few adjustments, the microscope easily adapts to individual preferences and work routines. In this connection, effortless work combines with high-performance and the microscope meets the user's needs down to the smallest detail. This Leica DM Series is one of the most ergonomic microscope lines on the market today – and an excellent choice for fatigue-free work; fast, reliable results; as well as excellent cost-effectiveness – the benefits of a microscope tailored to individual user routines.

CONFIGURED FOR SPECIFIC AND UNIVERSAL APPLICATIONS

Leica DM1000-3000 microscopes are designed for applications in biological, medical and clinical laboratories; from routine tasks to research.

- > The Leica DM1000 provides comfort as well as optical brilliance, and is ideal for the clinical and biological laboratory.
- > In addition, the Leica DM2000-3000 feature a sophisticated focus mechanism – 2-gear or optional 3-gear focusing, with torque adjustment and adjustable stage height stop.
- > The Leica DM2500 also offers powerful 100 W illumination and is well-suited for pathology and biomedical research that require specialized contrast methods such as differential interference contrast (DIC).
- > The “intelligent automation” of the Leica DM3000 supports greater intuitive efficiency and enhanced user comfort. The microscope is designed for clinical laboratories, all biomedical routine and research applications, and is ideal for pathology applications where the user spends hours at a time at the microscope.
- > The Leica DM1000 LED, DM2000 LED, DM2500 LED and DM3000 LED provide additional convenience with LED transmitted light illumination for constant color temperature and in case of the DM1000 LED with an optional, portable power supply.
- > Optionally, all microscopes can be equipped with fluorescence contrast. The Leica DM1000 – 3000 microscopes can be uniquely tailored to specific laboratory applications.

Cytology

High-performance HI PLAN 10x CY SL screening objective, light intensity synchronized with HI PLAN 40x.

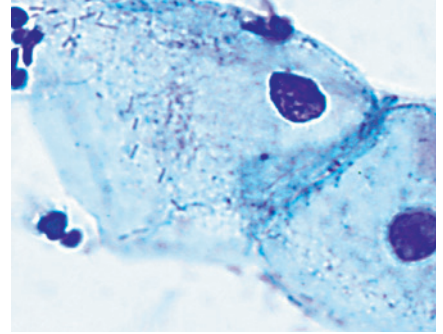

Pathology

Ultra-hard ceramic stage surface ensures long product life. The 1.25x objective provides a clear overview.

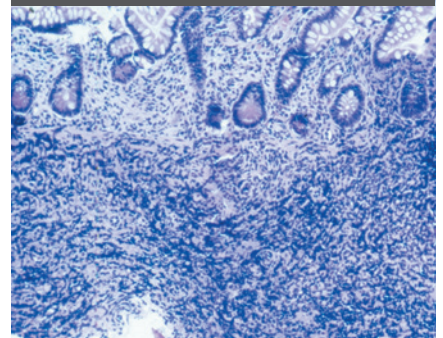

Hematology

Easy, single-handed operation (for x/y/z) when simultaneous counting or written notation is required.

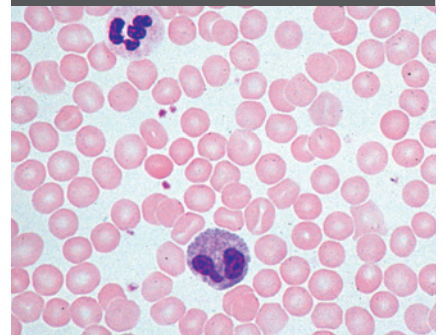



EFFORTLESS MICROSCOPY MEANS COMFORT

The Leica DM1000-3000 Series makes routine work as comfortable and effortless as possible. Only a few hand adjustments are required to adjust the microscope to the user's seat height, head posture, arm length and hand size. This adaptability provides reliable protection from muscular tension, poor posture, and long term, detrimental health effects. Microscopy has never been more comfortable and pleasant.

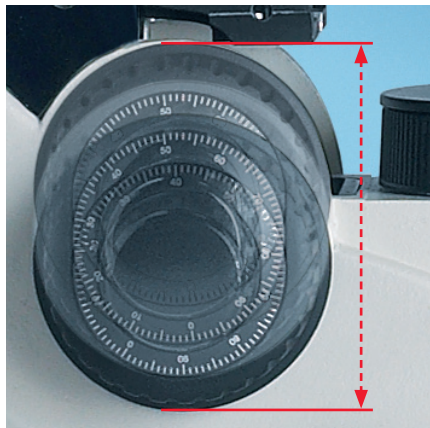

Height-adjustable Focus Knobs⁽¹⁾

A technological novelty

No two hands are alike. And so the Leica DM1000-3000 series enables every hand to rest on the focus knobs in complete comfort. The focus knobs can be precisely adjusted to fit the user's hand. This prevents hand, arm and shoulder tension and ensures a comfortable, fatigue-free grip – without additional arm supports.



Adjustable Tubes

Relaxed head posture eases tension

Proper arrangement of the tubes promotes good posture while sitting at the microscope. The Leica DM1000-3000 series offers a wide range of products to customize the tube settings. Choose from an ergonomic viewing angle of 15° or adjustable variotubes for a relaxed head position while viewing. Customized tube positioning prevents neck and back muscle strain as well as shoulder and lower neck muscle tension even over lengthy work sessions. Leica's optional ErgoLift even adjusts the viewing height and angle of the entire microscope stand to adapt to the user's body.



True Symmetrical Operation

Symmetrical shoulder posture provides comfort

The stage drive and focus knobs are arranged at the same height on the microscope, forming a straight line and are positioned at an equal distance from the user. Because of this symmetry, both hands are comfortably aligned during work and the shoulders automatically assume a right-angle position to the body's axis. The result: the user sits at the microscope in a straight, relaxed posture.

(1) Patented DE 103 40 721 B3; CN 100538430 C; JP 4677213 B2; US 7,233,435



Fast Changeover from Right- to Left-handed Operation⁽²⁾

One-of-a-kind!

The user can set up Leica DM1000-3000 microscopes for either right- or left-handed operation as the default. This feature is especially beneficial when different users are sharing one microscope.

Differential Interference Contrast

Optical contrast methods such as Darkfield, Polarization, Phase or DIC provide brilliant images. Ready for a universal condenser and any 6- or 7-position objective turret.

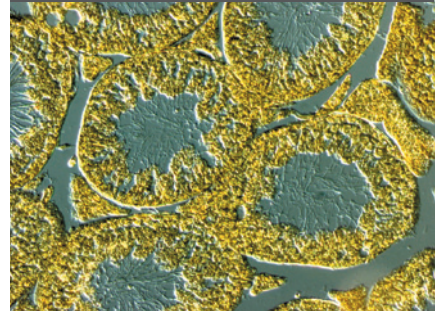

Unique Ultra-hard Surface

Designed to last a lifetime

The microscope's stage surface is made of a new, hard ceramic that makes the stage resistant, even under the most rigorous usage. The light beige color of the ceramic stage plate⁽³⁾ provides an ideal surface on which to identify specimens by outline and coloring before placing under the objective.

Fluorescence

High-intensity fluorescence with zero pixel shift for all kinds of probes and labels.

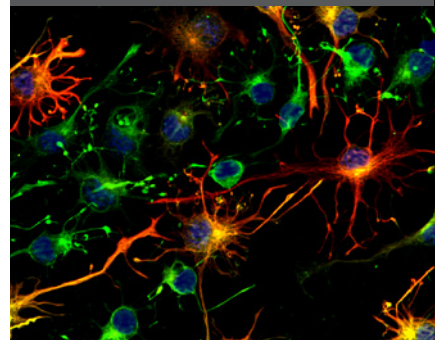

Ergonomic Control Knobs

Comfort is at hand

As an alternative to the standard knobs, Leica's rubberized ErgoKnobs are available to provide a comfortable secure grip for the focus drive. For the x-y drive knobs, replaceable sleeves made of soft, yet firm rubber are included with the stage drive. Simply pull the sleeves over the knobs to enhance the feeling of sensitive control.

Histochemistry

Best contrast for viewing autoimmune reactions.

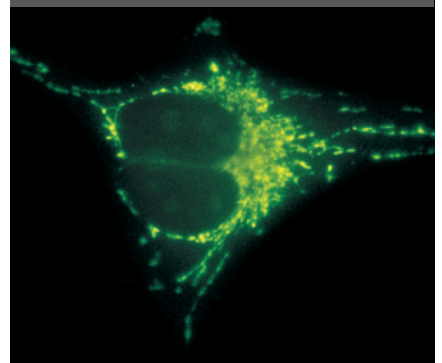

Comfortable ErgoLift

Variable height adjustment

Leica's optional ErgoLift is a special, adjustable plate that raises or lowers the entire microscope to the seat height of each user with just a few hand movements. The patented height-adjustable hand rests⁽⁴⁾ ensure comfortable work.

New Design

More work space

The design of the stage is rounded, and the entire microscope is compactly designed with no protruding parts. The compact design frees additional work space around the microscope.

(2) Patented DE 10 2004 053 437 B4; US 7,283,295; JP 4886995; US 7,330,306; CN 100445795

(3) Patented EP 1 627 938 B1; US 7,345,817

(4) Patented DE 103 05 195 B4; US 7,136,222 B; US 7,468,833

ELEGANT DESIGN FOR EFFICIENT, HIGH-QUALITY WORK

Better performance, higher throughput, and faster workflow: three important benefits that provide maximum efficiency to today's laboratories. Microscopes with well-engineered functions down to the smallest hand movements allow users to work quickly and smoothly. The Leica DM1000-3000 series is thoughtfully and elegantly designed to provide these benefits.



New Slide Holders

Ergonomic design means efficient work

Leica's new slide holders help to make microscope work easier. The slide holders are designed in a way that specimens can be changed with one hand – and one hand movement. The specimen is inserted into the holder and removed from it using just two fingers. This ensures a fast, fluid workflow.



Premiere: Color-coded Diaphragm Settings

Faster identification and adjustment

The aperture diaphragm's scale (on the condenser) features color-coded markings, which correspond to the standardized color codes of the objectives. At a glance, the user can identify the diaphragm that best matches the currently selected objective, and then quickly and correctly configure the settings.

Easy Lamp Replacement⁽¹⁾

Efficient maintenance

The lamps can be replaced easily and in very little time. Just remove the socket from the side of the microscope, replace the lamp, and reinsert the socket into the microscope – and the task is done. The microscope does not need to be moved to replace the lamp.

Long lifetime LED

Another option: the new Leica DM1000 LED, DM2000 LED, DM2500 LED and DM3000 LED with long-lasting LED illumination means lamp changes are a thing of the past.



Simultaneous Focus and Stage Control

One-handed adjustment

The focus and stage can be adjusted with just one hand to allow faster, more efficient workflow. While one hand (left or right) focuses the specimen, the other hand is free for other tasks, such as taking notes.

(1) Patented DE 10 2005 010 961; US 7,048,402; CN 100397137

EXCELLENT IMAGE QUALITY: OPTICAL BRILLIANCE

Leica microscopes are well-known for their excellent optics. Users can expect Leica's renowned excellent image quality and exceptional viewing comfort. Leica DM1000-3000 series features a host of innovative functions that enable the user to quickly and reliably configure the optical settings for the best viewing conditions. Leica's objectives provide brilliant, high-contrast images. The optical system is designed to reduce eyestrain and ensure fatigue-free work at the microscope.



Leica's Renowned, High-quality Optics

The best brightness, brilliance and contrast

The Leica DM1000-3000 series features spectacular optical quality. The viewer can expect brilliantly detailed images with razor-sharp contrast. Leica's high-quality optics clearly reveal the finest cellular structures, which makes identification easy. Leica's HI PLAN plan-achromat objectives offer improved field-flattening and color correction. The HI PLAN 10x objective is particularly well-suited for cytology applications. Its long working distance of 12 mm allows specimens to be marked at 10x magnification.

The objectives from any Leica Microsystems' performance class can also be used, including the high-performance objectives from PL Fluotar class to Leica Aplanochromats with PL APO class for superior imaging quality



The New Fluorescence Axis

Five filter block positions provide greater flexibility

Leica's stable, high-quality fluorescence axis features five filter block positions. Users can rapidly switch back and forth between them. Leica's extensive range of filters can be used with a wide variety of fluorochromes. Leica's filter blocks feature unique "zero pixel shift" technology which ensures perfect image alignment of multiple fluorescence proteins.

Brightness-matched Objectives

No need to adjust light intensity

Leica's HI PLAN SL (Synchronized Light) objective series with 4x, 10x, 20x, and 40x magnification is particularly easy on the eyes. Leica's SL objectives are synchronized with each other so that brightness always remains constant for the user, regardless of the selected magnification. This eliminates the need to continuously adjust the brightness and reduces the eyestrain that can occur due to large fluctuations in light intensity when changing the objective. The preferred color impression remains the same for each objective.



Overview Objective

1.25x objective – for screening

Leica Microsystems offers a screening objective with 1.25x magnification. Specimens can be surveyed and recorded quickly and easily.



Planachromat Objective

Excellent field-flattening and color correction

Leica's special Planachromat HI PLAN CY 10x/0.25 objective provides excellent field-flattening and color correction, and offers a long working distance of 12 mm for clinical applications. This objective is also available in the SL version.

INTELLIGENT AND INNOVATIVE

THE AUTOMATED LEICA DM3000 AND DM3000 LED

Even faster, more comfortable, and more efficient: the Leica DM3000 microscopes combine operating convenience with an ergonomic design. The automated Leica DM3000 & DM3000 LED optimize work processes while adapting to each user's physical requirements. A technological novelty! With its unique patented toggle mode⁽¹⁾ for changing objectives and automated condenser head, the intuitive Leica DM3000 & DM3000 LED provide high speed and precision while maintaining reliability in all biomedical routine and research applications.



Change Objectives at the Touch of a Button

Eyes stay focused and hands remain in place

Leica's motorized objective turret allows to change magnification in only half a second. Two buttons, conveniently located behind the focus knobs, or six buttons on the base of the microscope control the turret. Leica's perfect toggle mode: any two of the six objectives can be assigned to the buttons behind the focus knobs. The remaining four objectives are available at the touch of a button whenever a different magnification is required. Six buttons on the base of the microscope are assigned to the six objectives. An optional foot pedal is also available, which frees the user's hands for activities such as taking notes.

Automated Condenser Head

Ergonomic and efficient work

The automated condenser head automatically swings out when using objectives with less than 10x magnification and swings back into position when a higher magnification is selected. The microscope knows the best condenser position for every objective. For special applications, the user can individually adjust the condenser position by assigning this position to a control button. Leica's automated condenser head accelerates workflow in the laboratory.

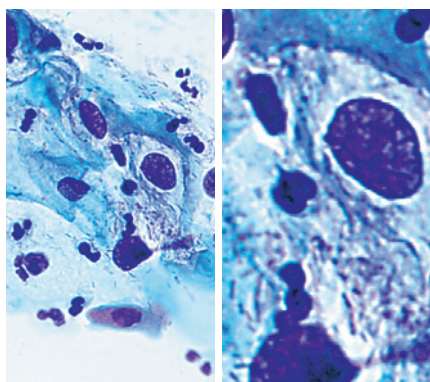

Automatic Light Intensity Adjustment

Optimal light for any magnification

Whenever the objective is changed, the Leica DM3000/3000 LED automatically adjust the light intensity. The user's most recently used light values are stored for each objective. This prevents sudden light intensity changes that can cause eyestrain.

(1) Patented DE 10 2005 013 152 B4; US 7,570,421

MICROSCOPY IN A NEW LIGHT

THE LEICA DM1000 LED, DM2000 LED, DM2500 LED AND DM3000 LED

The Leica DM1000 LED, DM2000 LED, DM2500 LED and DM3000 LED microscopes offer additional convenience with long-life LED transmitted light illumination. LED illumination provides constant color temperature at all light intensity levels without heating up the specimen. The LED's high light density and optimal color reproduction provides brilliant images with a clear differentiation of the colors in the sample. The Leica DM2500 LED with LED lamphousing guarantees ultra-bright LED illumination, ideal for highly light-absorbing specimens and contrasting methods like DIC. For the Leica DM1000 LED, Leica offers an optional portable version for field-based use.

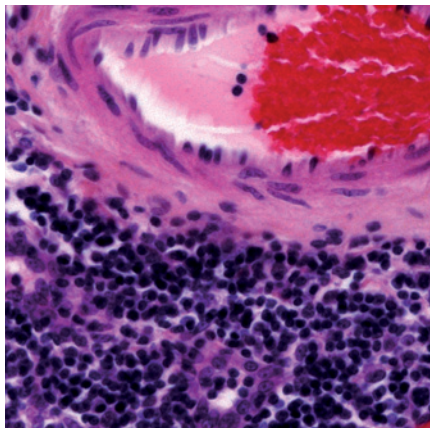

Optimal Lighting

The LED transmitted light illumination provides constant color temperature at all light intensity levels, clear differentiation of colors and is easy on the eyes – for reliable results and less fatiguing work.

Bulb Replacement is History

With extremely long lifetime LED of at least 50.000 hours, the LED illumination is very cost-effective, as frequent bulb-exchanges are no longer necessary.

Energy Savings

Due to the low power consumption of LED, the system is energy efficient.



Portability

Leica offers an optional, portable power supply for Leica DM1000 LED for field-based applications. The microscope can then be used for up to eight hours on a fully charged battery.

INTEGRATED SYSTEM SOLUTIONS



Digital Microscope Cameras

Leica Microsystems' full line of color cameras and cameras for fluorescence applications offers a solution for any requirement between highest resolution and quick live image.

Microscope Imaging Software Leica Application Suite LAS

Easy and Efficient

The Leica Application Suite (LAS) microscope software offers fully developed features for visualization, archiving, analysis and detailed documentation of your work at the microscope. Extension modules are available for a wide range of applications



Leica Application Suite X – Imaging and Analysis Software for Life Science Research

Leica Application Suite (LAS X) is the easy to use software platform for advanced life science research with Leica Microsystems microscope systems and is ideal for the whole spectrum of fluorescence applications from routine work to sophisticated imaging tasks in biomedical research such as fast multidimensional fluorescence scans and processing.

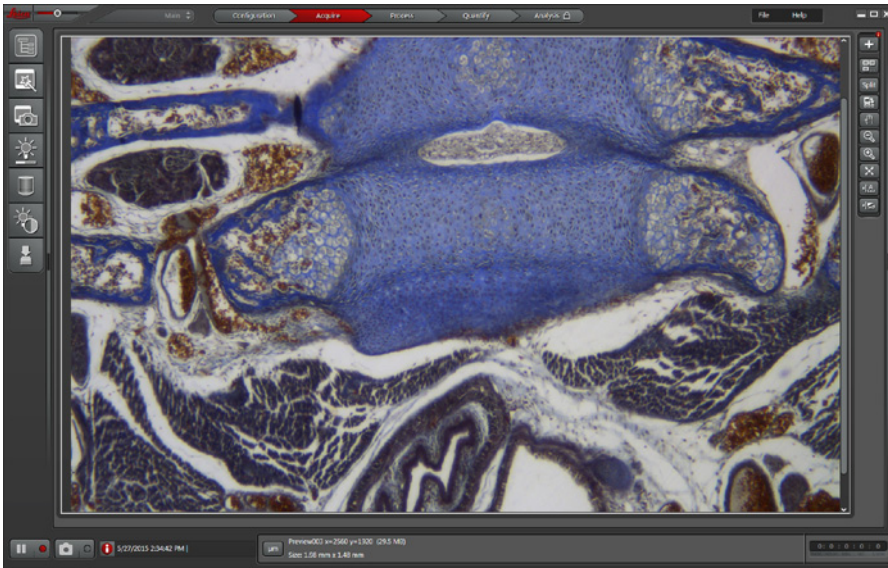

SPECIFICATIONS

Leica DM1000/DM1000 LED

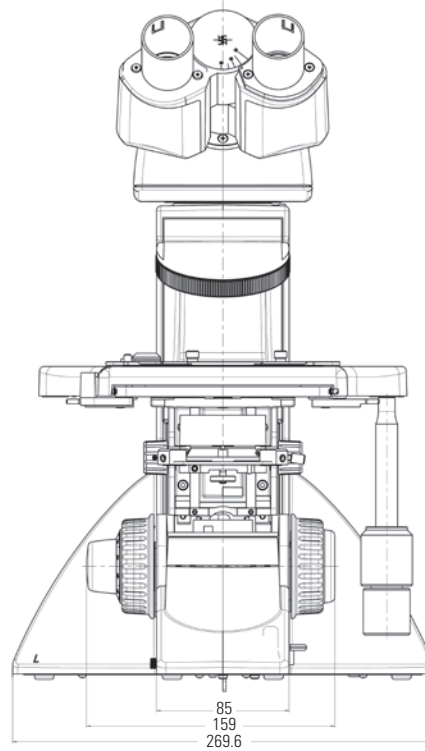
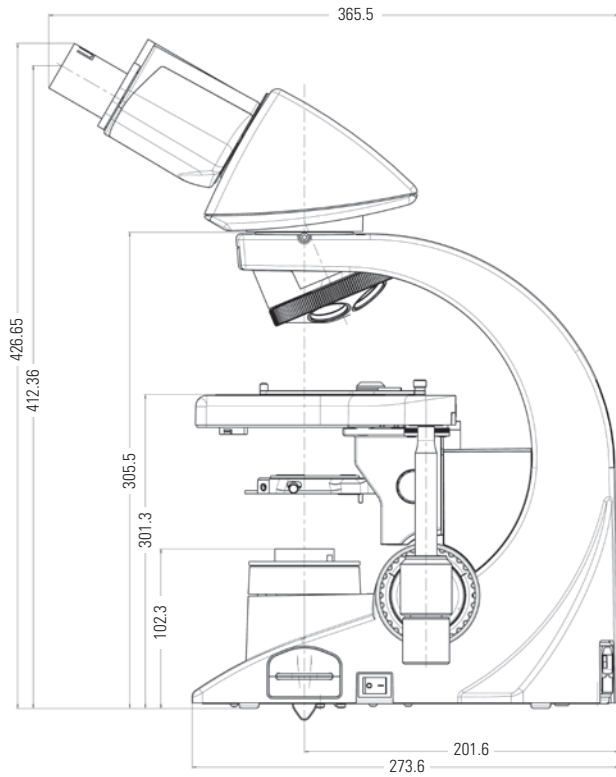

Leica DM2000/DM2000 LED, DM2500/DM2500 LED, DM3000/DM3000 LED

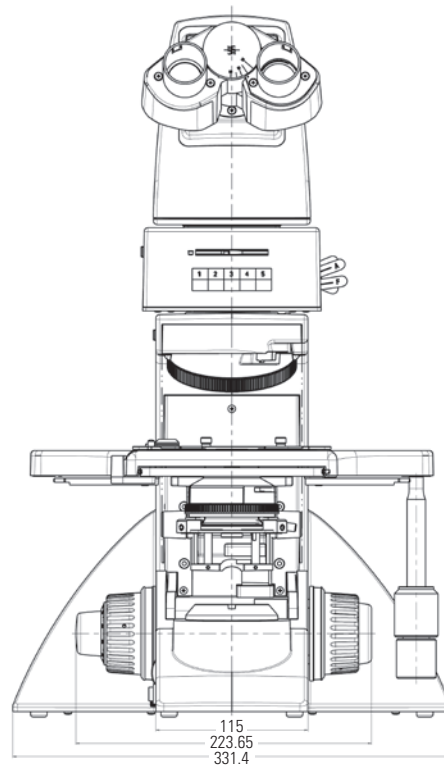
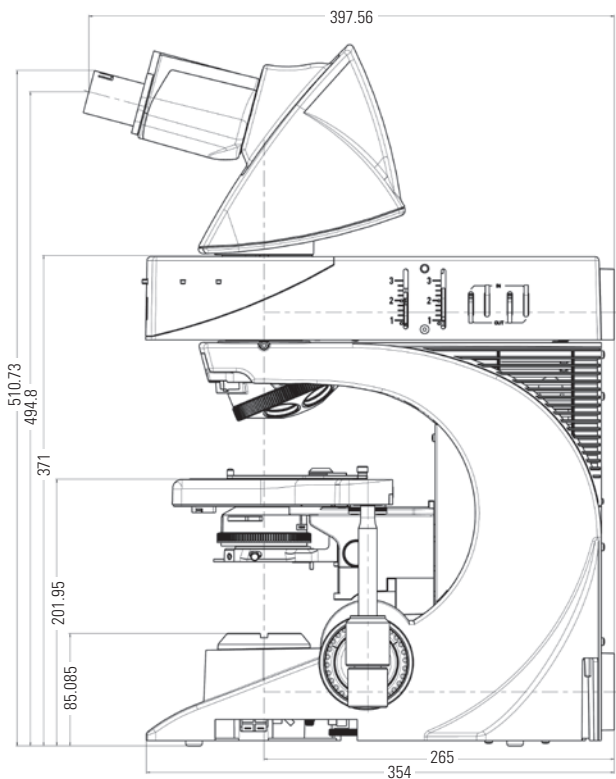

SPECIFICATIONS			DM1000	DM1000 LED	DM2000	DM2000 LED	DM2500	DM2500 LED	DM3000	DM3000 LED	
		Unique features									
STAND	Power supply	External		•							
		Integrated	•		•	•	•	•	•	•	
	Koehler	Variable Koehler Illumination	•	•	•	•	•	•	•	•	
		Prefixed Koehler	•	•							
	Eyetubes	Ergotube 15° viewing angle FOV 22	•	•	•	•	•	•	•	•	
		Standard tube 30° viewing angle FOV 22	•	•	•	•	•	•	•	•	
		Ergo tilting eyetube FOV 25 (long)	•	•	•	•	•	•	•	•	
		Ergo tilting eyetube FOV 22 (short)	•	•	•	•	•	•	•	•	
		Advanced ergo tilting eyetube FOV 22	•	•	•	•	•	•	•	•	
	Phototubes	Trinocular ergo tilting phototube 50/50 FOV 22	•	•	•	•	•	•	•	•	
		Trinocular ergo tilting phototube 100/100 FOV 25	•	•	•	•	•	•	•	•	
		Trinocular ergo tilting phototube 50/50 FOV 25	•	•	•	•	•	•	•	•	
		BDT25 0/50/100 dual port option FOV 25	•	•	•	•	•	•	•	•	
		EDT22 50/50 FOV 22	•	•	•	•	•	•	•	•	
Ergomodels	30 mm or 60 mm	•	•	•	•	•	•	•	•		
	variable 50-80 mm	•	•	•	•	•	•	•	•		
OPERATION	Focus	Height adjustable focus knobs	•	•	•	•	•	•	•	•	
		2-gear focusing: coarse, fine, focus stop	•	•							
		5 focus functions: 2- or 3-gear focusing, focus-stop, adjustable torque			•	•	•	•	•	•	
	Objective turret	5-fold	•	•							
		6-fold			•	•	•	•	•		
		7-fold			•	•	•	•	•		
		Automatic 6-position objective turret with additional toggle mode								•	•
	Objective	Brightness synchronized objective series 4x, 10x, 40x	•	•	•	•	•	•	•	•	
	Light intensity adjustment	Automatic light intensity adaptation for varying magnifications							•	•	
	Stage	Ceramic-coated (ultra hard ceramic)	•	•	•	•	•	•	•	•	
		Left/right (exchangeable by user)	•	•	•	•	•	•	•	•	
		Rackless	•	•	•	•	•	•	•	•	
		Telescopic drive	•	•	•	•	•	•	•	•	
		Adjustable torque	•	•	•	•	•	•	•	•	
		Rotatable / stage for two slides (option)	•	•	•	•	•	•	•	•	
	TL AXIS	Illumination	Integrated LED illumination		•		•				•
			12 V/30 W halogen lamp, easy bulb-exchange (with special drawer)	•		•				•	
LED illumination with LED lamphousing								•			
Filtering		12 V/100 W halogen lamp with lamp house					•				
		Flip-out blue filter	•	•	•	•	•	•	•	•	
		Filter holder for 2 filters	•	•	•	•	•	•	•	•	
		Filter magazine for 3 filters	•	•	•	•	•	•	•	•	
Condenser		Built-in filter magazine for 3 filters					•	•			
		Standard condenser CL/PH color coding (2.5x–100x)	•	•	•	•	•	•	•	•	
		Achr. Apl. Flip top condenser color coding (1.25x–100x)	•	•	•	•	•	•	•	•	
	Automated Achr. Apl. Flip top condenser with color coding (1.25x–100x)								•	•	
Contrast methods	Universal condenser UCL BF/Phase/DF	•	•	•	•	•	•	•	•		
	Universal condenser UCA BF/Phase/DF/DIC			•	•	•	•	•	•		
	BF	•	•	•	•	•	•	•	•		
	DF, PH, POL	•	•	•	•	•	•	•	•		
FLUO-AXIS	Illumination	DIC			•	•	•	•	•	•	
		50 W or 100 W Hg	•	•	•	•	•	•	•	•	
		75 W Xe	•	•	•	•	•	•	•	•	
		12 V/100 W halogen lamp	•	•	•	•	•	•	•	•	
	Filter cube changer	Leica SFL100/SFL4000	•	•	•	•	•	•	•	•	
		Slider with 3 positions for filter cubes	•	•							
		5-position filter cube turret			•	•	•	•	•		

www.leica-microsystems.com



© 2019 by Leica Microsystems CMS GmbH, Wetzlar, Germany.
Subject to modifications. LEICA and the Leica Logo are registered trademarks of Leica Microsystems IR GmbH.



Leica Microsystems GmbH · Ernst-Leitz-Strasse 17–37 · D-35578 Wetzlar
T +49 64 41 29-40 00 · F +49 64 41 29-41 55

www.leica-microsystems.com

CONNECT
WITH US!

