

USER MANUAL



THE PURPOSE OF THIS MANUAL IS TO TRAIN THE USER TO A CORRECT USE OF THE AGRICULTURAL IMPLEMENT IN COMPLIANCE OF SAFETY RULES IN ORDER TO SAFEGUARD THE HEALTH AND TO PREVENT INJURY.

NORMATIVE REFERENCE

This manual was written in compliance of the following law:
Directive 89/392/C and amended UNI EN 292/2 – 1992. DPRN. 547 27/04/55 – work's safety rules.

HOW TO READ AND USE THIS MANUAL

This manual is the part of the machine and of the initial provision.

That means it must be kept for all machine's life, also in case of selling it to others.

Further copies of this manual must be requested through buying an order from the manufacturer or its dealer.

It is not allowed to use the machine without a previous careful reading of this manual, only trained operators may use it.

The employer is responsible for the disclosure of this document to all the employees who will work with the machine.

After following what is written in this manual the operator must follow the general safety rules as in law prescriptions of destination's country.

It is strictly prohibited to make whatever kind of modifications to the machine or to this technical document.

GENERAL INFORMATIONS

IDENTIFICATION DATA OF THE AGRICULTURAL IMPLEMENT

The manufacturer's identification is made in conformity of the legislation through the following points:

- DECLARATION OF CONFORMITY
- CE MARK
- USER MANUAL

DANGER WARNINGS

The agricultural implement is equipped with pictograms which recall risks.

On Picture 2 is indicated the points where the labels are located.

DELEKS Srl

Via Industriale, 23 - 25028 - Verolanuova (BS) - ITALY

Phone: +39-030-6585725 - E-mail: info@deleks.com

www.deleks.com

DECLARATION OF CONFORMITY WITH EUROPEAN DIRECTIVE

FIG. 2

Product: Snow remover
Type: LNS 130; LNS 150; LNS 170; LNS 190; LNS 210
Serial Number:
Application manufacturer:
DELEKS SRL
Via Industriale, 23
25028 VEROLANUOVA (BS) Italy
The submitted sample of the above product has been tested for CE marking according to the following European Directive:
Machines Directive 98/37/EC
Harmonized rules EN292-1/EN292-2/EN294/EN414
The CE marking as shown below may be affixed on the product.

Certificate number
Date

.....
 ALESSANDRO DEL BONO



1. Read the manual before use
2. Turn off the tractor before to make maintenance on the machine
3. Keep safety distance from the tool, feet shearing risk
4. Keep safety distance from the working machine, 15 meters
5. Never step over the machine
6. Danger don't put the hands
7. Prohibition sign
8. Warning's label fitting to tractor.

OVER ALL DIMENSIONS

MOD. (LNS)	130	150	170	190
BLADE HEIGHT	500	500	500	500
BLADE WIDTH	1300	1500	1700	1900
ANGOL OF ROTATION	30°	30°	30°	30°
HP	14-40	14-40	18-40	18-40
WEIGHT	110	120	130	140

FIG. 3



GENERAL INFORMATION

AFTER DELIVERY INSPECTION

- The recipient will receive those items which were ordered
- Missing or damaged parts due to transporting should be communicated to the manufacturer

CAUTION

All the data and sizes are not bounded, the manufacturer reserves the right to modify them without former communication.

Any modifications will be communicated by further technical forms.

TRANSPORT OF THE MACHINE

To transport the items, it is necessary to follow the packing requirements.

IMPORTANT

To lift the item it is necessary to use ropes which are appropriate to the weight of the item. Check that ropes are not worn.

Lift the load gently and in case of sharp edges, protect the rope with packing material.

DESCRIPTION OF THE MACHINE

The snow plough is an implement which is fitted to agricultural tractors or 4WD trucks, it's used to remove the snow from the road to the desired side.

The side moving is possible cause the blade can be fixed to the left or to the right of about 30° by operating the hydraulic actuators.

SNOW BLADE PARTS

The snow blade is made of the following parts:

- fixed support with backplate connection equipped with bolts in the upper position for connection to the plate fixed on the tractor. There are 2 bolts on the lower side to lock the plate.
- Connecting pin, between the fixed support and the swivel, is the fulcrum around which the blade turns.

MOUNTING TO THE TRACTOR

The machine must be on flat terrain, the machine's feet must safely support it, so that the operator could easily fit the third point linkage.

Make sure that:

- a) The blade is perpendicular to the ground.
- b) Check that the locations of the couplings on the backplate are clean and free of debris.

Assembling:

- Approach with the vehicle to the blade, and fix the upper bolts.
- Link the hydraulic connectors.
- Insert the coupling screws and tight them.
- Check the correct movement of the implement by operating the hydraulic distributor.

USE OF THE IMPLEMENT

Use:

This implement is used only for snow removing.

The max operating speed must be 15 km/h.

But the speed must be appropriate for the street condition by the operator.
During the use of the snow plough, the visibility must be good enough to prevent damages by moving the snow on the side of the way.
Malfunction:
Slow moving of the snow blade.
There might be not enough oil in the system.
Inordinate back down of the cylinders:
It is necessary to check the max pressure valve on the distributor.
Slow return of the blade:
If after passing an obstacle the blade stays forward inclined, the springs are worn or the regulations are wrong, regulate the springs or replace with new one.

RISKS ARISING FROM THE USE OF THE SNOW BLADE



DANGERS

Overturning of the blade.
Breaking of the mechanical parts.
Accidental falling of parts and accessories.
Crushing people.
Crash or slip of the blade.
Shearing.
Risks from lift and lowering of mechanical parts.

It is important to remember to use the maximum caution, during the work.
Never let inexperienced people to operate the machine.

ATTENTION

The operator must ensure that the implement has been connected to the tractor, following the instructions of this manual. The operator must observe the rules. He is responsible for following the instructions of this manual.
Before fitting the implement to the tractor, check that there are any missing parts from the list "SNOW BLADE PARTS".
Check the integrity of the snow plough.
Place the machine in suitable working area.
Check that there is enough space around the machine to let correct operating during the assembling.

Before operating, acquire suitable protecting clothing.
Do not wear torn clothing, undone, watches, rings or any other clothes, accessories and things which can catch the moving parts of the machine.

PRESCRIPTIONS FOR THE ROAD USE

Safety devices. During the road use, it is necessary to place a lock device on the cylinder which operates the lift of the blade, to prevent its accidental falling. This device must be removed during the operating.
During the road transfer the max speed for trucks is 40 KMH and 20 for the tractors.
The vehicle must be equipped with:
Revolving warning lamp;
Additional projectors to ensure visibility after the fitting of the snow remover
Side lights;
When necessary, rear ballast.

MAINTENANCE

A regular maintenance and appropriate use is necessary for a long life of the implement.

For that purpose:

Grease the pivots, pins, all the joint parts and where is required each 50 working hours.
Check periodically that there are any lose bolts.
Check the integrity of hydraulic cylinders and hoses at regular intervals.
Check the oil level each 50 working hours.
Attention
Each maintenance operation must be done with the machine disconnected from any power source, in a clean, open and not wet place.
Do not stay under the suspended parts.

SPARE PARTS DRAWING

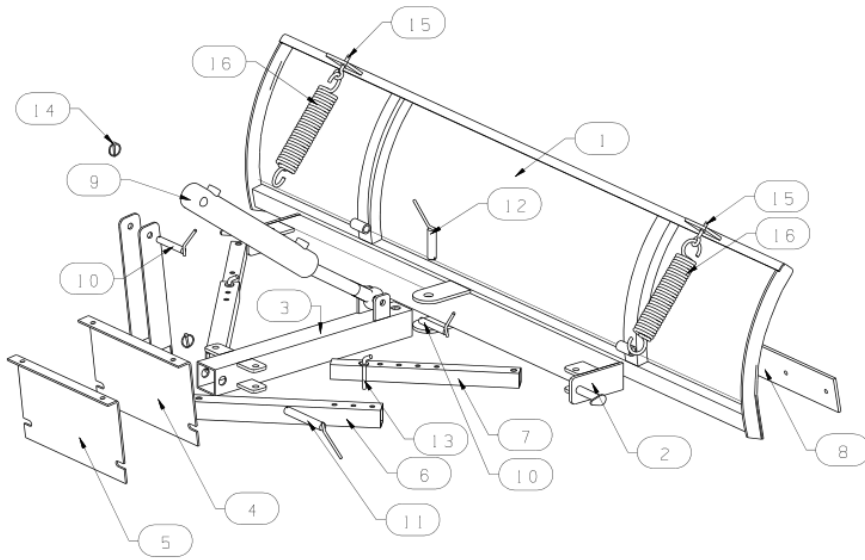

13	Pins
14	R Locked
15	Bolts
16	Spring

NO.	NAME
1	Blade
2	Fix tube
3	Cylinder fix tube
4	Fix plate of cylinder
5	Plate of tractor
6	Adjustable tube of outside
7	Adjustable tube of inside
8	Snow blade
9	Cylinder
10	Cylinder pins
11	Pins
12	Pins



DELEKS Srl

Via Industriale, 23 - 25028 - Verolanuova (BS) - ITALY

Phone: +39-030-6585725 - E-mail: info@deleks.com

www.deleks.com