





MEGASYSTEM-C

Tumor and Revision System

Surgical Technique

CE 0482

Explanation of Pictograms			
	Manufacturer		Article number
	Material (number)		Product meets the applicable requirements, which are regulated in the EU harmonization legislation for the affixing of the CE marking.

02	Indications/Contraindications Patella Resurfacing
02	Preoperative Planning
03	System Overview
04	Important Information on Implantation of MEGASYSTEM-C Components
	Surgical Technique
05	Standard Preparation Tibia
12	Standard Preparation Femur
20	Assembling the Tibial Components
25	Proximal Tibial Replacement
28	Distal Femoral Replacement
29	Bone Preparation without using a Recess Ring
32	Push-through Prosthesis
38	Proximal Femoral Replacement
38	Total Femoral Replacement
39	Intercalary Diaphyseal Reconstruction
39	Optional: Patella Preparation (Patella Resurfacing)
44	Modular System Overview: Assembly Applications
	Implants
52	Neck Segments
53	Proximal Spacers and Expansion Bolt
54	Prosthesis Heads
55	Stem Components
57	Interprosthetic Sleeves (RescueSleeve – Custom-made prostheses)
58	Joint Components Endo-Model SL for Rotating and Non-Rotating Hinge Knee
63	Proximal Tibial Spacers, Tilastan and UHMWPE, for Endo-Model SL Rotating and Non-Rotating Hinge Knee
65	Modular Stems with male and female taper
68	MEGASYSTEM-C – Endo-Model Modular Joint Components: Condylar Replacement, Intracondylar Version
69	Centralizers, LINK Patella Components
	Instruments
70	Overview Instrument Sets MEGASYSTEM-C
74	Instrument Set – Tapered Reamers: 100 mm
75	Instrument Set – Tapered Reamers: 130 mm
76	Instrument Set – Tapered Reamers: 160 mm
77	Instrument Set – General Instruments I
78	Instrument Set – General Instruments II
79	Instrument Set – Femur I
80	Instrument Set – Femur II
81	Instrument Set – Tibia
82	Instrument Set – Femoral Trial Stems: 100 mm, 130 mm, 160 mm
84	Instrument Set – Tibial Trial Stems: 100 mm, 130 mm, 160 mm
85	Instrument Set – Trial Prostheses: Femur/Tibia, intracondylar
86	Instrument Set – Trial Prostheses: Distal Femur and Proximal Tibial Replacement
87	Instrument Set – Trial Prostheses: Total Femur Replacement
89	Instrument Set – MP Trial Implants
90	Instrument Set – Assembling
91	Assembling Instruments for MEGASYSTEM-C
98	Instrument Set for Patella Components, 3-pegs
99	Additional Instruments: Adapters, Sawblades
101	Accessories: X-ray Templates
102	Additional Information: Surface Modifications
103	Further Information: Literature
104	Indications/Contraindications
	Important Information

Indications/Contraindications Patella Resurfacing

Patella Resurfacing is not a necessary part of the method for implantation of a total knee replacement. It is an optional procedure carried out if femoropatellar syndrome is present.

Contraindication

The specific contraindications for the knee system Endo-Model SL and Endo-Model Modular Joint Components with female taper (Endo-Model –W) being used must always be observed.

Account must also be taken of the following:

- Degree of retropatellar arthrosis
- Patient's height and weight
- Pre-existing anterior knee pain

Preoperative Planning

Measurement tables and X-ray templates are available for the preoperative planning of revision and tumor surgery with the MEGASYSTEM-C Modular Components which enable the surgeon to plan precisely the implants that will be used.

True-to-scale radiographs or precise knowledge of the actual magnification factor are the foundation for exact preoperative planning. LINK X-ray templates show the implant illustrations in 110% magnification as standard. If different scales are desired, we will meet these wishes as far as technically possible. We provide data for digital planning on request to providers of digital planning software in the current formats.

Despite good preoperative planning, unforeseeable extensive bone loss in tumor and revision cases often presents a challenge for the surgeon. Especially in these cases the Endo-Model SL Rotating and Hinge Knee Prosthesis also in conjunction with the MEGASYSTEM-C – proves its user friendliness. There is a high degree of modularity and flexibility in the adaptation of the implants to the respective bone situation in 10-mm steps.

In contrast to the use of normal hip and knee joint prostheses, management of extensive bone loss depends on the conditions in each individual situation. Structural changes in the muscles and ligaments, fixation conditions etc. increase the operative demands of tumor prostheses. Accordingly, management of extensive bone loss presents particular problems and is therefore subject to greater risk compared with the use of normal joint prostheses.





MEGASYSTEM-C
Tumor and Revision System

ENDO-MODEL SL
Rotational and Hinged
Knee System

Important Information on Implantation of MEGASYSTEM-C Components

- 1) In comparison with primary hip and knee implantation, the bone conditions for anchoring the prosthetic components are often very difficult when megaprotheses are indicated and often necessitate compromise solutions. The useful life of the prostheses cannot be compared with that of primary joint arthroplasty.
- 2) Compensation of large bone defects is often associated with weakening of the soft tissues. The resulting alteration in biomechanics can also have a negative effect on the durability and function of the prosthesis.
- 3) The infection risk is usually much greater with tumor or revision surgery than with primary procedures.
- 4) Prior to use of MEGASYSTEM-C implants, detailed preoperative planning is essential.
- 5) Correct leg length adjustment reduces the stresses on the implant components, the tapered connections and the bone/implant connections.
- 6) The assembly instruments for MEGASYSTEM-C must always be used to join the implant tapered connections.
- 7) Whenever possible, the tapered connections should be joined outside the patient on the MEGASYSTEM-C operating table.
- 8) Before securing the tapered connection with the locking screw, the connection must first be made using the appropriate assembly instruments (see instructions for use) (the components must be hammered together before being screwed).
- 9) The cones must be clean and dry before they are joined.
- 10) The locking screw should generally be used from the medial side. When the operative access is difficult, the implants provide the option of using the screw from the lateral side. Only one screw should be used.
- 11) When changing the locking screw, a new screw must always be used.
- 12) In revision operations, a new implant component should always be used as far as possible. Should an implant remain in the body, the cone must be protected from damage.
- 13) If a tapered connection is separated by means of the distraction instrument (15-8506/52) or the cone surfaces are damaged, the two implant components involved must not be reused.

Standard Preparation Tibia



Intramedullary Alignment

01

Mark the entry site with the bone awl (317-658/01) and open the tibial canal with the conical drill (15-6037/00).

02

Mount the awl of the previously planned length (100 mm, 130 mm or 160 mm) at the handle (15-6053/00). The impaction plate (16-3203/00) latches into the slot on the shaft of the awl.

When uncemented modular stems are used, ream with an increasing diameter until the awl makes cortical contact over a continuous distance of approx. 50 mm. The uncemented implant that will be used must correspond in length and diameter to the last awl used.

For cemented modular stems, the awl should be at least 2 mm larger than the planned stem diameter.

CAUTION:

The position of the impaction plate represents the level of the joint line. Using the awls with a power tool is not permitted.



03

After the desired stability is achieved, the handle (15-6053/00) and the impaction plate (16-3203/00) are removed.



04

Attach the connector (16-3212/08) to the shaft of the awl.

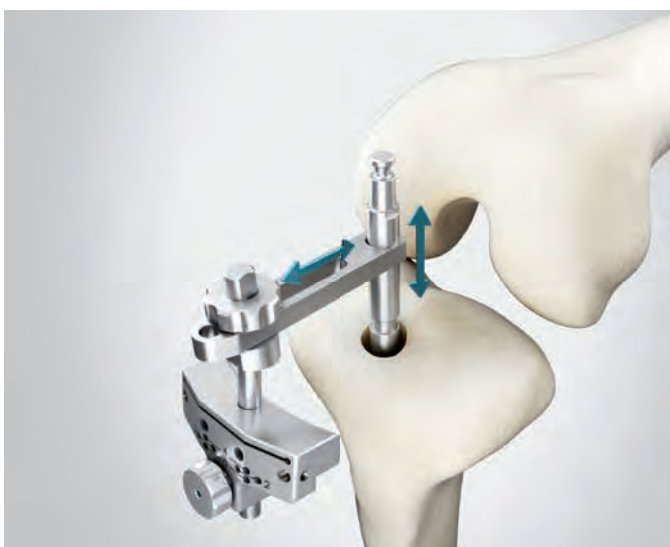

05

Attach the tibial saw guide (16-3241/00) to the anterior shaft of the connector and fix it provisionally by tightening the knurled screw.

**06**

Attach the stylus for the tibial saw guide (317-802/52), preferably medially. The stylus tip marked **10**, marks the resection level in the primary procedure (10 mm resection level). The stylus tip marked **2** can be used in revision surgery and marks a resection level of 2 mm. Alternatively, the stylus can be omitted and the resection level can be set using the cutting template (317-607/50).

**07**

The tibial saw guide (16-3241/00) is fixed to the proximal tibia by means of two wire pins (317-585/65 or /95) through the lower row of parallel holes.

**08**

The bone is resected following removal of the stylus, connector and awl. The resection can be extended distally by 2 mm or 4 mm by shifting the tibial saw guide.

To achieve the correct resection geometry, sawblades with a thickness between 1.24 mm and 1.27 mm must be used.

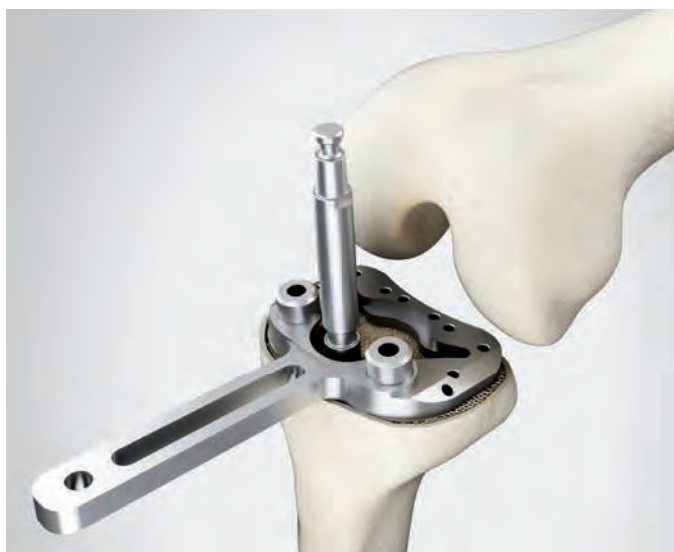

09

The last-used awl is inserted into the medullary cavity again. By placing the drill template (16-3198/12, /13, /14) that corresponds exactly to the implant size, the definitive implant size is determined. It is important that the implant covers the resection surface as far as possible. Projection over the cortical margin of the tibia must be avoided.



10

The alignment gauge (16-3266/00) is placed over the shaft of the awl and connected to the pegs of the drill template. After rotational alignment of the drill template, it is fixed to the resection surface with at least two wire pins.



For rotational alignment, the alignment rod (16-3242/00) can be pushed from ventral onto the drill template. The ventral alignment rod must be aligned in the area between the middle of the tibial tuberosity and its medial margin.



11

Removal of the alignment gauge. The awls Ø 19–24 mm must also be removed temporarily and then reinstalled.



12

Attach \varnothing 16 mm drill guide (16-3267/00) and drill the proximal tibia (manually or machine-operated) with the \varnothing 16 mm drill (16-3207/16) until stop.



13

After removing the \varnothing 16 mm drill guide, the drill guide (16-3270/18, /20, /22) is attached to drill the central tibial opening. The drill guide must correspond to the size of the drill template.



14

Drill the central tibial opening manually with the drill corresponding in diameter to the drill guide (16-3208/18, /20, /22) until stop.

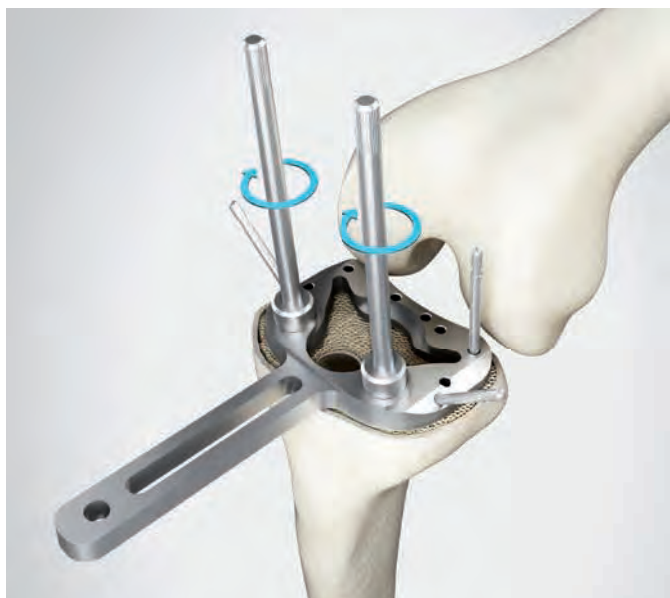

15

Screw the guide rods (16-3211/00) into the anterior threaded holes of the drill template.



16

Screw the stem compressor (16-3201/02, /03, /04) to the corresponding compressor (16-3199/12, /13, /14) for the proximal contour. Attach the handle (16-3197/00).

17

Drive in the compressor over the guide rods until the compressor touches the drill template.



18

Preparation of the tibia is now complete.

Standard Preparation Femur

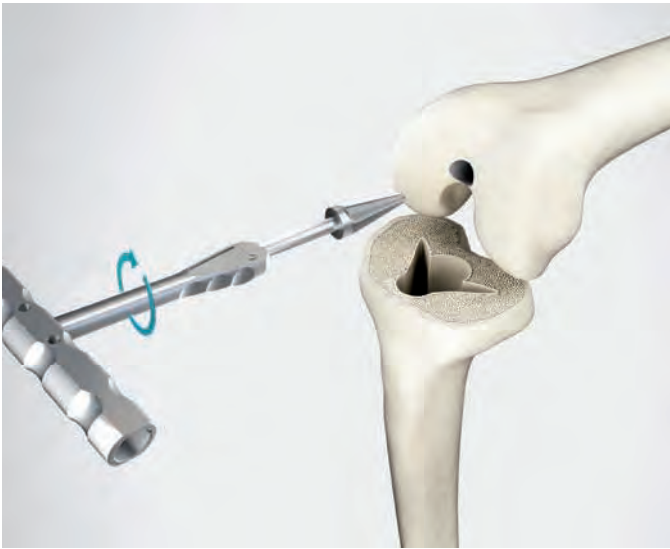

19

Mark the entry site with the awl (317-658/01) and open the femoral canal with the conical drill (15-6037/00).

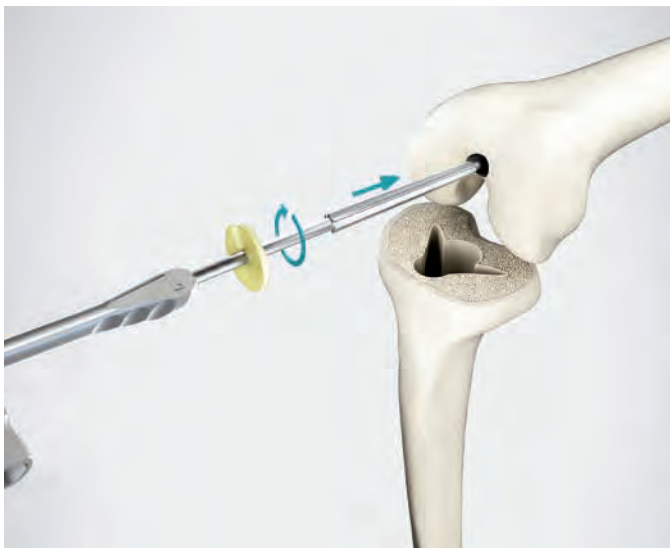

20

Mount the awl in the planned length (100 mm, 130 mm or 160 mm) in the handle (15-6053/00). The impaction plate (16-3203/00) latches into the slot on the shaft of the awl.

When uncemented modular stems are used, ream with an increasing awl diameter until the awl makes cortical contact over a continuous distance of approx. 50 mm. The uncemented implant that will be used must correspond in length and diameter to the last awl used.

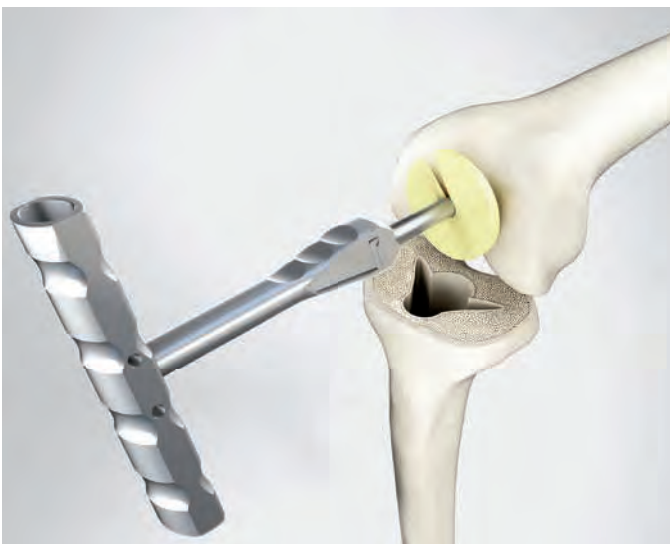

21

For cemented modular stems, the awl should be at least 2 mm larger than the planned stem diameter.

CAUTION:

The position of the impaction plate represents the level of the joint line. Using the awls with a power tool is not permitted.



22

Remove the impaction plate and attach the alignment instrument for valgus angulation (16-3275/00). Ensure that the correct instrument for the right or left side is attached. The word **“Left”** or **“Right”** must face upward.



23

The appropriate saw block (16-3228/02, /03, /04) for the distal saw cut – according to the previously determined size – is fixed to the valgus alignment instrument using the clamp. The cut can be simulated with the cutting template (317-607/50).

There is a +3 mm slot for proximal offset of the cut or the instrument can be moved by +2 mm after it is fixed by wire pins.

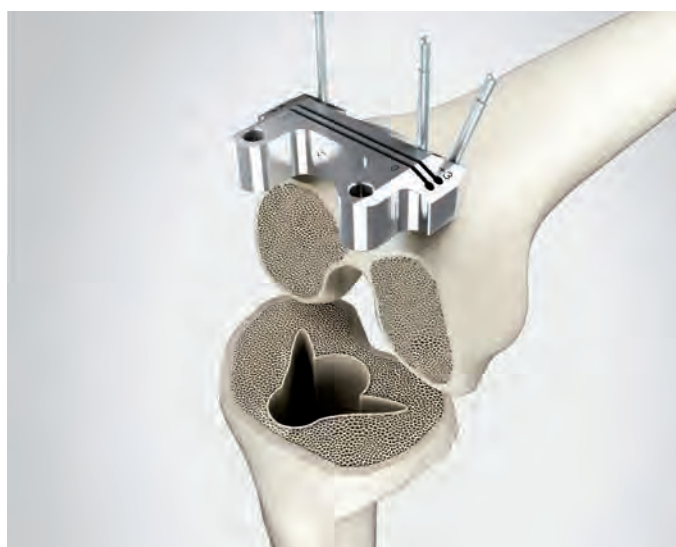

24

After fixing the saw guide by means of two parallel and one oblique wire pins, the valgus alignment instrument and the awl are removed and the distal cut is made.

To achieve the correct resection geometry, sawblades with a thickness between 1.24 mm and 1.27 mm must be used.

**25**

With the alignment instrument for determination of external rotation (16-3276/00), the selected femoral size is first set and fixed with a pin. The alignment instrument allows external rotation to be set to 0°, 3° and 5° with reference to the posterior condylar tangent. Alternatively, external rotation can also be aligned using the Whiteside line with the small dipstick in the center of the instrument. Small alignment rods can be attached medially and laterally for orientation to the epicondylar line (Insall line). Deficits in flexion and extension gap can be balanced by using femoral segments or tibial spacers.

**26**

Once the correct position is found, the instrument is fixed with two wire pins through the medial and lateral holes.

**27**

After the wire pins and alignment instrument have been removed, the dove tail adapter (317-802/36) is inserted in the depressions created by the wire pins.

**28**

The femur cutting block for chamfer cuts (16-3250/02, /03, /04) is pushed onto the side of the dovetail adapter and the central hex screw is fixed in the selected position with the hex screwdriver, wrench size 2.5 mm (10-5373/01). Two wire pins can then be inserted for additional fixation. The anterior cut is made first, then the dorsal and finally the anterior and posterior oblique cut.

To achieve the correct resection geometry, sawblades with a thickness between 1.24 mm and 1.27 mm are to be used.

**29**

Before the trochlea is prepared with the chisel (317-802/32) for the patellar gliding groove, the cutting block for chamfer cuts is aligned somewhat lateral to the center. Then the chisel is connected to the diver extractor (15-8516/45), and the trochlea is then prepared with it.

**30**

Following preparation of the distal femur, the last-used awl is inserted into the medullary canal again.



31

The condyle cap (16-3241/02, /03, /04) is placed on the prepared bone surfaces. The shaft of the awl forms the center. Through the ventral saw slots the bone can be prepared, matched to the femoral segments in 15 mm, 25 mm or full.



32

A drill cap (16-3213/02, /03, /04) of the same size as the condyle cap is placed on the pegs of the condyle cap. The word “**Left**” or “**Right**” must be faced upwards.



33

Using the center sleeve (16-3281/00), the instruments are aligned and centered on the shaft of the awl.



34

Following alignment, the drill cap is fixed to the condyle cap with the holding clamp (16-3279/00). The condyle cap is fixed to the bone with two wire pins. The center sleeve and awl are removed. If necessary, the drill cap must also be removed temporarily and then re-attached again.

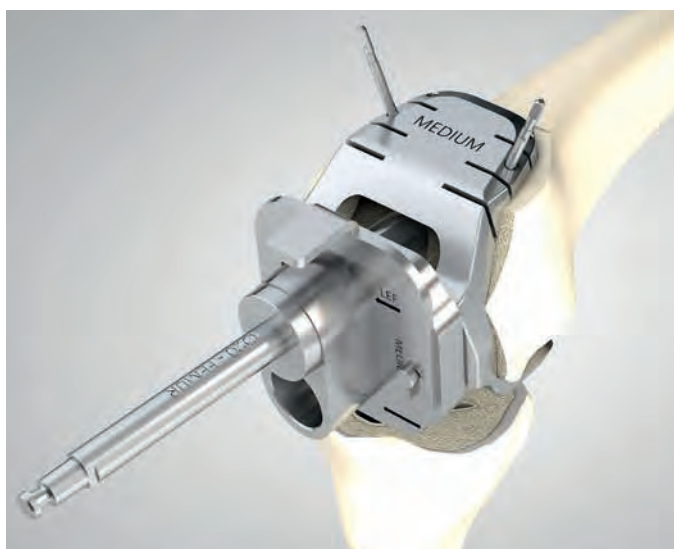

35

The drill for femur \varnothing 20 mm (16-3206/20) is inserted as far as stop.

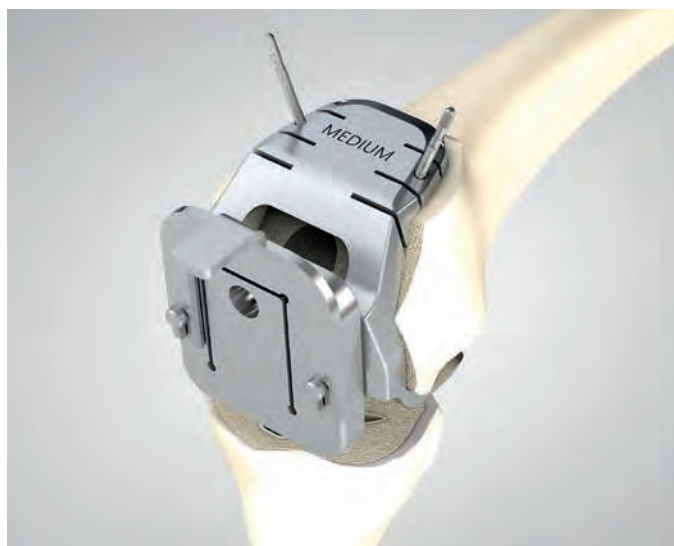

36

After removing the holding clamp, the drill cap is removed, the saw attachment matching the selected prosthesis size (e.g. 16-3223/02) is attached and secured again with the holding clamp. The femur box is then prepared with an oscillating saw.



37
Preparation of distal femur is complete.



38
The tibial trial stem and trial prosthesis are joined by screwing them together and inserted into the prepared tibia.



39
The femoral trial stem and trial prosthesis are joined by screwing them together and inserted into the prepared femur.



40

Connect the two joint pieces by inserting the dorsal recess of the trial axis into the axis of the femoral component and then pushing the tibia up. Fix the screw with the hex screwdriver (64-8008/02). Test the prosthesis. Deficits in the flexion and extension gap are compensated with femoral trial segments and/or tibial trial spacers. The components are separated by proceeding in reverse order.

INFORMATION:

A combination of several femoral segments or proximal tibial spacers is not allowed!



41

Remove the trial femoral and tibial components with the extraction instrument for trial prostheses (15-6061/00).

Assembling the Tibial Components



42

The tibial stems are fixed by means of a tapered connection on the tibial component. It should be ensured that the flanges of the prosthetic stems are inserted into the intended slots. The stem is then fixed to the tibial component with screw assembly. **Screws are only to be tightened hand-tight.**

INFORMATION:

When using cemented modular stems or the monobloc tibial component, the use of centering stars is mandatory. They might not be part of the sterile package for tibial components 16-2817/02, /05 and /07 when indicated.

After the underside of the tibial prosthetic component has been coated with a thin layer of bone cement, the prosthesis is inserted into the tibia with the impactor (16-0018/02)

43

By tightening the locking screw (2) located in the taper (3) of the tibial respectively femoral component its pointed tip presses the stem (1) firmly onto the taper. A counter screw (4) secures the stem locking screw against loosening. The screw fixation is performed medially. **Screws are only to be tightened hand-tight.**

INFORMATION:

The locking screw (optionally pre-assembled), the counter screw and one replacement screw each are included separately in the packaging.

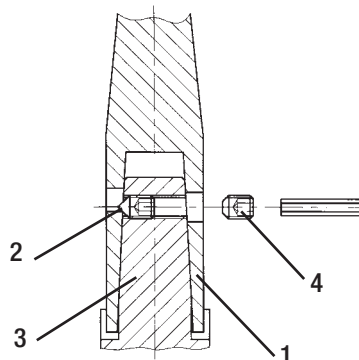
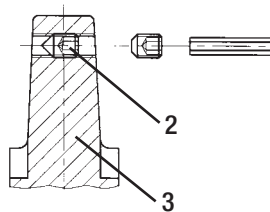

Counter Screw





44

Until the bone cement has set, the trial screw remains in the prosthesis thread in order to protect it (excess bone cement is removed). After the cement has set, the plateau securing screw is removed with the hex screwdriver (64-8008/02).

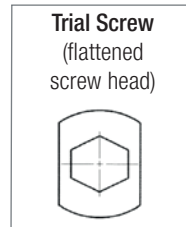

The femoral prosthetic component coated with bone cement is placed on the femur and gently tapped home with the impactor (317-646/01) until the implant fits snugly (excess bone cement is removed).



INFORMATION:

If the intention was to use a tibial component with pre-assembled PE sleeve and tension plate these parts are no longer required, as they are now form part of the connecting components.

INFORMATION:

Bone cement must be used to fix femoral segments onto the intracondylar femoral components.



45

After the bone cement has set, the transport lock is removed by loosening the screw joint with the screwdriver (10-5373/01) and withdrawing the lock with slight rotation.



The PE-Plateau is connected to the inserter (15-8035/03).

If required, the PE plateau can be inserted after the connection component (rotating version) has been assembled.

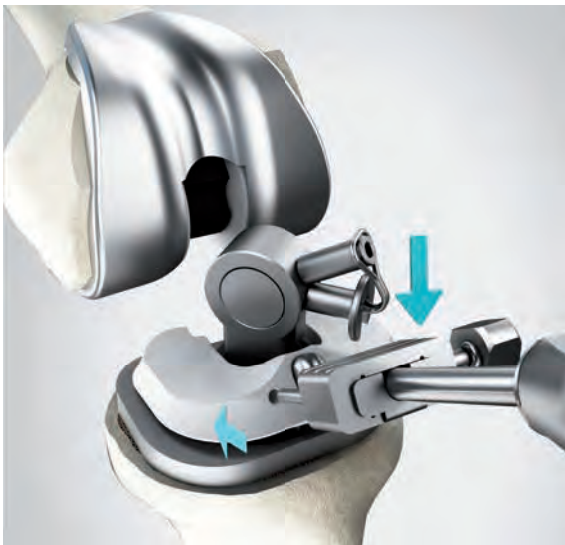

46

The connector with the rotation axis is put on the tibial component, and the PE plateau with the inserter (15-8035/03) is then inserted and screwed home. The self-locking screw is screwed with the hex screwdriver (64-8008/02). For easier access to the plateau retaining screw, the connector is rotated slightly.

Self-locking Screw
(round screw head)

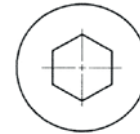

CAUTION:

The self-locking fixation screw may only be used during the final assembly of the plateau. Loosening the fixation screw destroys the screw retention system in the polyethylene plateau, and a new plateau must then be inserted.



47

The connecting component is inserted into the intracondylar slot of the femoral component. The tibia is placed as far posteriorly as possible, relative to the femur. Then the U-shaped opening of the securing sleeve is rotated 180° until the opening faces upwards. The securing sleeve can then be pulled upwards along the spring wire, thereby unloading the spring so that it presses the axis halves outwards. The prosthesis axis is inserted into the bushings by slightly lifting the connecting component and carefully moving the joint components. A 2-mm-torque wrench hex screwdriver (15-2546) is used to tighten the securing screw, which is already in the sleeve. Then the axis lock is removed.



The screw must be tightened until an audible “Click” is heard that indicates that the required torque has been applied, locking the connection component in place.



48

Check the position of the holes. When assembly is complete, the two drill holes in the prosthetic axis are located exactly under the arrow marks. Confirm that the set screw is slightly recessed. If it is not, remove the set screw, deploy the T-bushing with the connecting and separating forceps (16-0020/01 or /02) and reinsert the set screw, with the 2-mm-torque screwdriver (15-2546) until it is recessed.

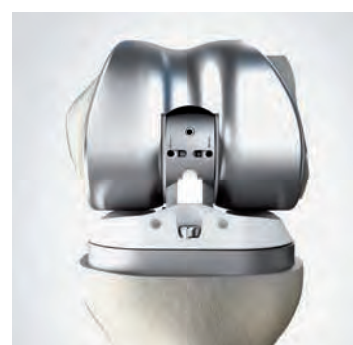
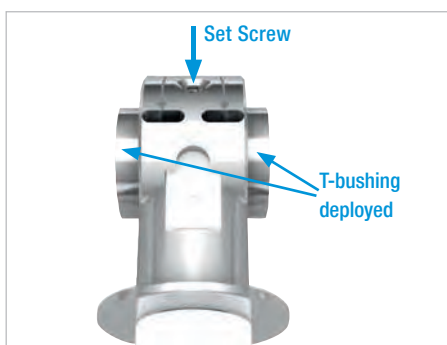
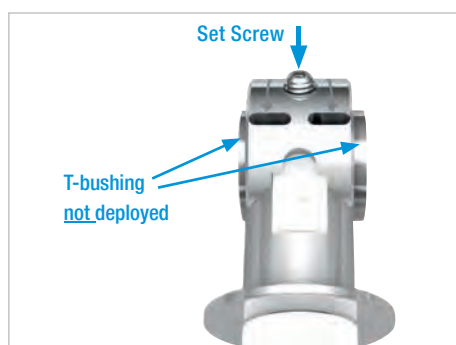

49

If use of a non-rotating hinged knee version is planned, the screws in the tibial plateau must first be removed with the hex screwdriver (15-2546). The connector with hinge axle is placed on the tibial component.

The connector is then screwed in place using the hex screwdriver (10-5373/01) and the PE plateau is inserted.





50

When assembly is complete, the two drill holes in the prosthetic axis are located exactly under the arrow marks. The PE plateau is then screwed home with the hex screwdriver (64-8008/02).

To decouple the connecting component, in the event of a revision, the securing screw is removed, the connecting and separating forceps (16-0020/01 or /02) are inserted, and the prosthetic axis is squeezed together. Then the connecting component can be decoupled ventrally.

Proximal Tibial Replacement



51

Resection of the proximal tibia at the planned level. Optional a support ring or terminal can be used (see page 56).



52

Mount the awl in the planned length (100 mm, 130 mm or 160 mm) in the T-handle (15-6053/00). When cementless modular stems are used, ream with an increasing diameter until the awl makes cortical contact over a continuous distance of approx. 50 mm. The cementless implant that will be used must correspond in length and diameter to the last awl used.

For cemented modular stems, the awl should be at least 2 mm larger than the planned stem diameter.

INFORMATION:

Using the awls with a drive motor is not permitted.



53

When use of a recess ring is planned as a flat attachment of the extramedullary part of the implant to the bone, the awl is inserted deeply into the medullary canal until the cutting edges of the awl are at the same level as the resection level. The handle is removed and connected to the reamer (16-3205/30) (using power tool optional).



54

The resection surface is reamed flat with the reamer, which is guided by the shaft of the awl.



55

The reamer and awl are removed. The saw guide for notching can optionally be used to prepare the notches with an oscillating saw (see pages 30/31).



56

The trial stem and trial prosthesis for proximal tibial replacement are joined by screwing them together and inserted into the prepared tibia.



57

The femoral trial stem and trial prosthesis are joined by thread attachment and inserted into the prepared femur.



58

The femoral trial prosthesis is assembled, inserted and connected as described under “standard preparation of the femur”. By extending, flexing and rotating the treated limb, it is possible to estimate the leg length and degrees of rotation and flexion.

Distal Femoral Replacement



59

Depending on the indication, the distal femoral replacement can be extended in 10 mm increments after an initial further resection of 30 mm. Bone preparation is performed as described above for proximal tibial replacement from resection to planning the resection surface.



60

In this situation, trial prostheses for stem elements (e.g. 16-3100/01) are assembled between the trial stem and trial prosthesis for distal femoral replacement. Depending on the resection length, different trial prostheses for stem elements can be combined together to represent the desired leg length.

When selecting the suitable size for the trial prosthesis (distal femur replacement) and the final implant, the maximum size of the implant component should be taken. Hereby, it is possible to avoid soft tissue atrophies which could complicate further revisions.

INFORMATION:

After positioning the support ring, the set screw must be fixed!

Bone Preparation: without using a recess ring (optional procedure)**61**

Resection of the bone at the desired site. The cutting edges of the awl are then inserted in the medullary canal 10 mm deeper than the resection level and the resection level is prepared with the step reamer (16-3204/18 up to a stem diameter of 18 mm, 16-3204/24 for 19 mm or more).

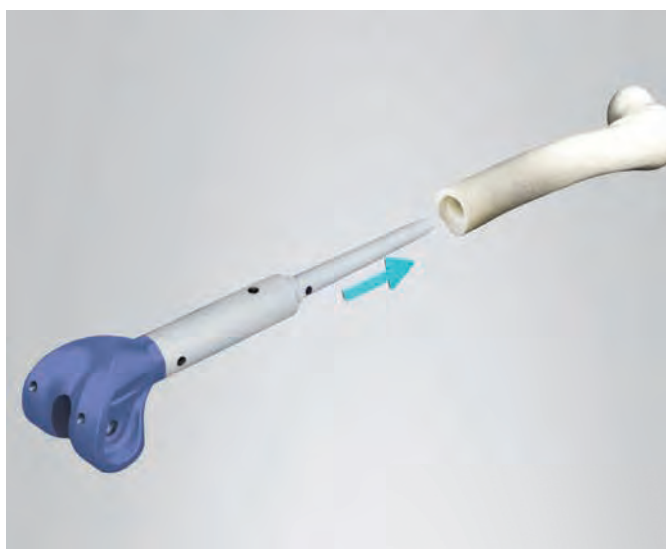
**62**

Assembling the selected trial prostheses.

**63**

The two guide rods (16-3235/00) are screwed into the adapter ring (16-3236/00) and placed from proximal to distal (vice versa in the tibia) through the two holes of the trial joint component.

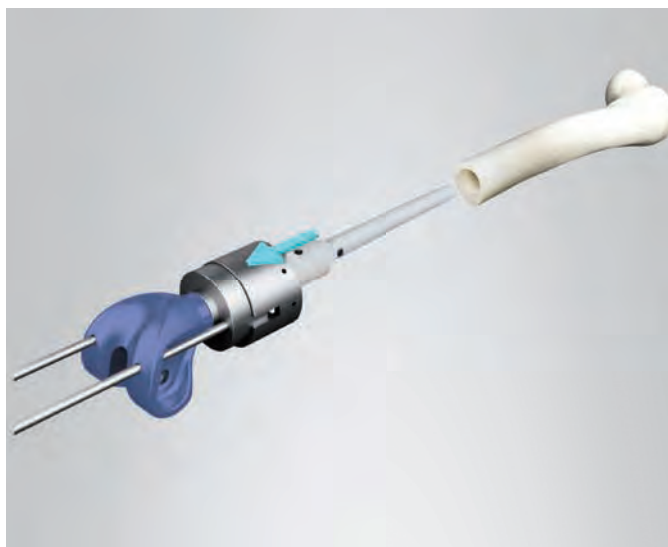

64

The saw guide for notching (16-3237/00) is placed on the adapter ring in such a way that the notch and spring engage.



65

The trial prosthesis is inserted into the bone as far as its final position. It is essential to ensure correct rotational alignment of the trial prosthesis. The adapter ring must sit flush on the resection surface.



66

The saw guide for notching is fixed with two wire pins. The trial implant with the adapter ring is then removed.



67

Preparing the notches with the oscillating saw.



68

Prepared notches.

Push-through Prosthesis



69

Prior to implantation of the push-through stems for total femoral replacement, the medullary cavity is reamed with ball reamers or flexible medullary reamers approx. 1 – 2 mm larger than the diameter of the selected prosthesis (available in 14 mm or 16 mm).

The length of the push-through prosthesis and the level of the femoral shaft resection should be chosen so that the sprocket for accepting the neck components is approximately 15 – 20 mm above the lesser trochanter. If necessary to adjust the length, this can be done by means of the proximal spacers (172-950/10, /20).



70

The push-through stems can be inserted directly with the femoral components as described in example 4 (see page 47) or as shown here, in combination with stem segments. The instruction for assembling the stem segments and modular stems is described on pages 94 ff. Fixation at the resection site is again optional (recess ring or notches).



The proximal part of the push-through prosthesis after implantation.

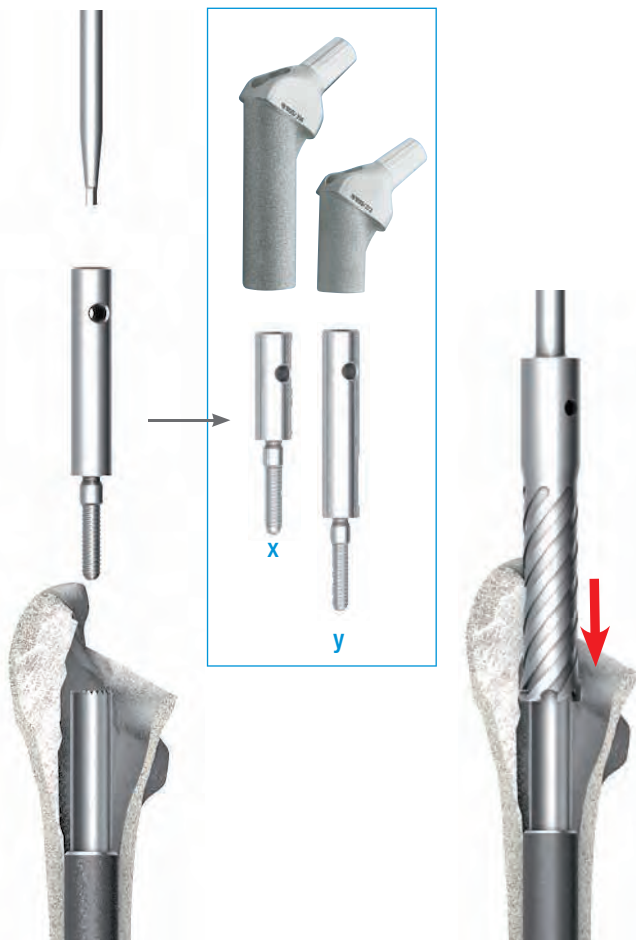

71

Preparation of the Metaphyseal Medullary Space

If required, a special hollow reamer (134-200/00) is used to prepare the implant bed for the neck segment (Fig. right).

There are two guides and stops available for positioning the reamer on the in-situ stem. Their length must be selected according to the neck segment being used (Fig. left).

Short reamer guide --> long neck segment (x)

Long reamer guide --> short neck segment (y)

The reamer guide can be screwed into the stem by hand or using the hex screwdriver (64-8008/02).

The reamer guide also serves as a stop to avoid the teeth of the hollow reamer (134-200/00) from coming into contact with the edge of the lower portion of the stem.

Irrigation is recommended to avoid overheating of the bone.



72

With the tubular reamer (134-200/00) the implant bed is prepared for the neck component. The selected neck component is then pushed on the sprocket of the push-through stem, the desired anteversion is obtained and the neck component is fixed with the trial fixation screw (134-100/41 or /61) using the hex screwdriver (64-8008/02).

73

Trial Reduction

The guide rod (G 134-201/00), which simplifies positioning of the trial neck segment (H) and, where used, the trial proximal spacers, is screwed into the thread of the implanted stem and fixed in place using a hex screwdriver (64-8008/02) (Fig. 01).

For the functional test, a trial neck segment (H) is mounted on the inserter (I 131-379/00), then pushed over the guide rod (G) and onto the implanted prosthesis stem. The teeth inside the trial neck segment must fit into the tothing on the stem.

The trial neck segment can be simply tested by turning it backward and forward (Fig. 02).

The secure seating should be checked with the caliper (K 134-202/00), which is placed on the trial neck segment (H). The connection is secure if – when no trial proximal spacers are used – the “0” gauge mark on the scale of the guide rod is visible in the recess on the caliper. The same applies accordingly for the “10” gauge mark when a 10 mm trial proximal spacer is used (Fig. 03).

The caliper and the guide rod are removed once the trial neck segment is in position. Depending on whether/which trial proximal spacers are used, a short trial screw (for no trial proximal spacer or a 10-mm trial proximal spacer) or a long trial screw (for a 20-mm trial proximal spacer or a combination of 10-mm and 20-mm trial proximal spacers) is screwed through the neck segment and into the stem and tightened with a screwdriver (Fig. 04), ensuring that the neck segment is aligned in the correct antetorsion.

Following positioning of a colored trial head (P), the hip can be reduced and its function checked (Fig. 05):

- Joint stability
- Range of movement
- Impingement





74

Colored plastic trial heads (175-928/11-14, 175-932/11-14, 175-936/11-14) in diameters 28 mm, 32 mm or 36 mm and neck lengths short, medium, long and extra long are used for trial reduction.

If leg lengthening is necessary, spacers can be used in the illustrated combination (see following images) when using neck components with a length of 65 mm. Trial spacers (131-398/10 or /20) are available for trial reduction.

75

Fixation Screws (trial and implant)

Spacers (trial and implant)

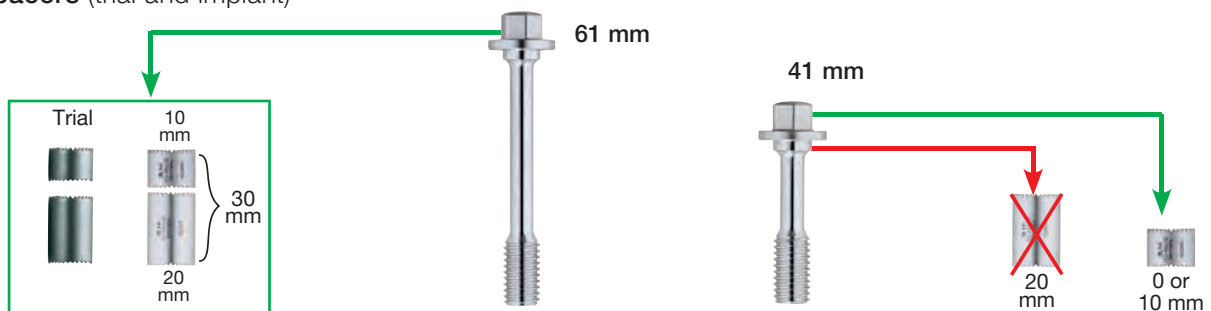

76

Neck Components (trial and implant)

Spacers (trial and implant)

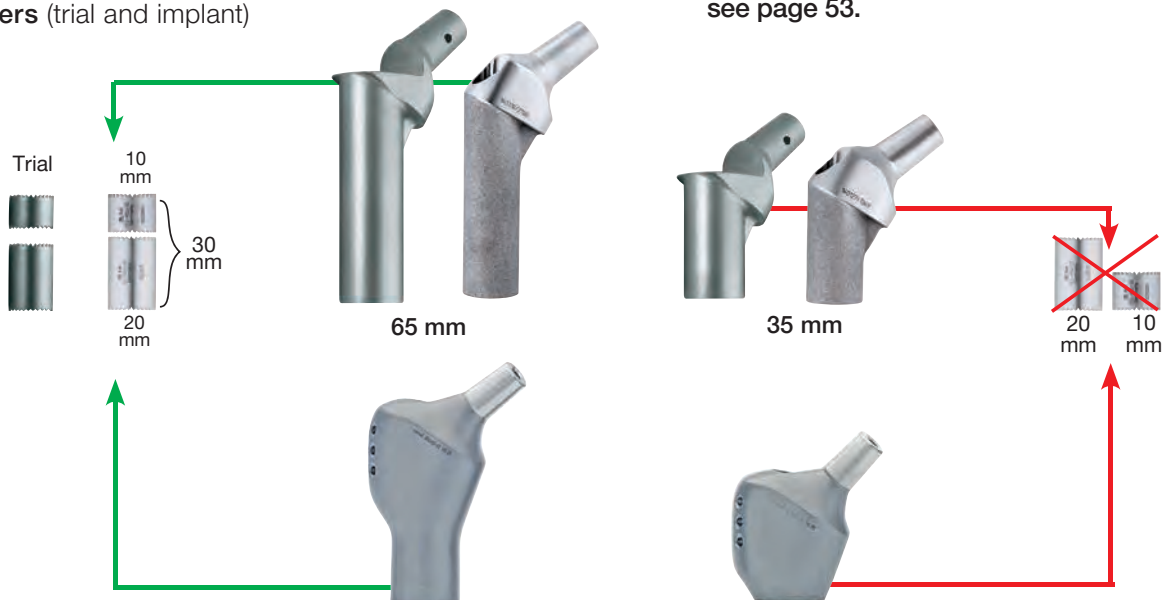

Notice:

Overview of the combination possibilities see page 53.

INFORMATION:

- Only the 65-mm neck segment may be used in combination with proximal spacers.
- A 35-mm neck segment may only be used without proximal spacers.

- Use of the short screw (41 mm): no proximal spacer or a 10-mm proximal spacer
- Use of the long screw (61 mm): a 20-mm proximal spacer or combination of a 10-mm and a 20-mm proximal spacer (30 mm in total)

77

After final leg length, antetorsion and joint stability are checked, the trial prostheses are removed. To assemble the final MP neck segment the same procedure should be used as for the trial prostheses. The guide rod (G) is screwed onto the stem again (Fig. 07). The neck segment and proximal spacers (if used) are placed over the guide rod (G) (134-201/00) onto the stem using the inserter (134-210/00) (Fig. 06). A marking made on the bone during the trial run is used to align the neck segment in the correct antetorsion position. The secure seating of the neck segment is checked with the caliper (K 134-202/00) in the same way as for the trial implant (Fig. 08). The connection is secure if, when no proximal spacers are used, the "0" mark on the scale of the guide rod (G) is visible in the "window" of the caliper. The "10", "20", or "30" scale marking must be visible when 10 mm, 20 mm, or a combination of 10 mm and 20 mm, proximal spacers are used.



78

Expansion bolts (172-947/38 or /58) are used for finally joining the neck component to the push-through stems. The screwdriver is used to screw the expansion bolt in all the way and tighten it gently (Fig. 09).



With loss of the proximal femur, the push-through stems can be combined with the neck segments (massive). The correct position of the implant and fixation with expansion bolts are checked as described previously.

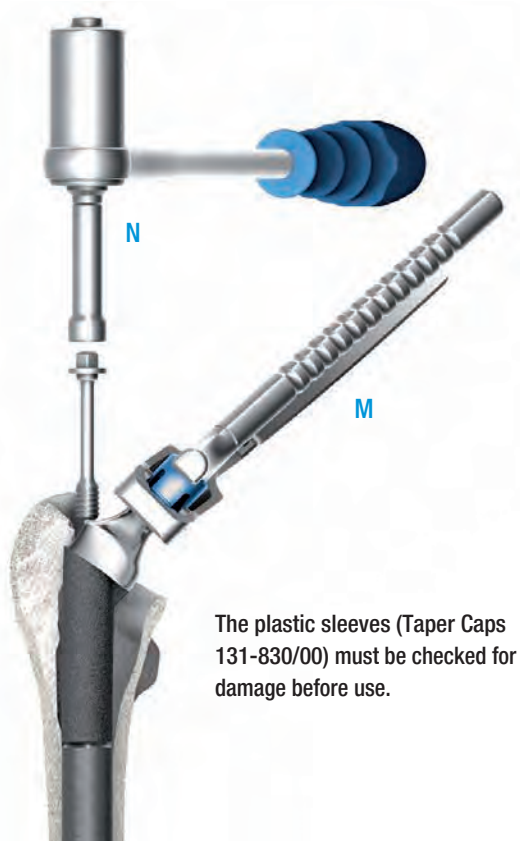

79

Expansion Bolts

The stem, proximal spacers if used, and neck segment are connected with a short (41 mm) or long (61 mm) expansion bolt (172-947/38 or /58), depending on the selected neck segment length and the number of proximal spacers. The bolt fixes the MP neck segments or neck segments (massive) securely to the modular MEGASYSTEM-C components.

INFORMATION:

LINK implants and expansion bolts can only be used once. It is not possible to reuse them because no expansion occurs when the bolt is tightened a second time. The torque wrench (N 134-140/00) is supplied with a calibration certificate and separate instructions for use, and must be subjected to a functional test after 250 uses. To this end, the instrument should be sent to Waldemar Link GmbH & Co. KG. The torque wrench must never be used to loosen screw connections, as this could have a negative effect on its function.

CAUTION:

There are two screw lengths available (41 and 61 mm):

- Use of the short screw (41 mm):
no proximal spacer or a 10-mm proximal spacer
- Use of the long screw (61 mm):
a 20-mm proximal spacer or combination of a 10-mm and a 20-mm proximal spacer (30 mm in total)



80

The neck segment is then gripped by the taper using the insertion forceps (M 134-141/00) and the expansion bolt is tightened using the torque wrench (N 134-100/00). The final prosthesis head is positioned on the carefully cleaned and dried taper of the neck segment and secured in place with a gentle blow on the inserter (130-600).

Proximal Femoral Replacement



81

Resection of the proximal femur at the planned site and preparation of the medullary cavity to accept the selected stem model as described under “Proximal Tibial Replacement“. Optional a support ring or terminal can be used (see page 56). After implantation of the modular stem, attachment of stem elements is optional.



82

Attachment of the coupling component for proximal femur replacement, short or long (15-8522/28 or 15-8522/30).



Attachment of the neck (massive). Fix the implant as described under “Push-through Prosthesis“.



Total Femoral Replacement

The total femoral replacement is a combination of the previously described treatments:

- Proximal femoral replacement
- Optional push-through prosthesis or bone replacement with stem segments
- Distal femoral replacement or intracondylar joint component
- Proximal tibial replacement as needed

Intercalary Diaphyseal Reconstruction



Resection of the femoral diaphysis at the planed sites and preparation of the medullary cavity to accept the selected tibial modular stems as described under “Proximal Tibial Replacement”. Optional a support ring or terminal can be used (see page 56).



Situation after implantation of the interposition components. The two interposition components are joined with the aid of the cross slot screw-driver (16-3290/00) and enclosed screws.

Note for lock bolts:
Beveled side is inserted first!

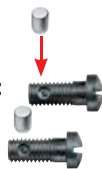

The coupling is intended for diaphyseal replacement.



Optional: Patella Preparation (Patella Resurfacing)

The following operating instructions describe the use of the **LINK Patella Component** and assume the use of the instrument set available for this procedure. Both the “resection” of the patella surface technique and the “reaming” of the patella surface technique are shown.

Determination of patella height/patella resection

Using the calliper (65-2000) allows the height of the patella to be determined (1). The dimension is established and an amount corresponding to the size of the selected implant subtracted. The remainder equals the target dimension following resection. A minimal residual dimension of 12 mm should be maintained.

Example:

For a patella size 2 (patella diameter 28 mm), the following calculation is performed:

1. Patella 25 mm thick,
2. resection 8 mm,
3. 17 mm remaining patella bone.

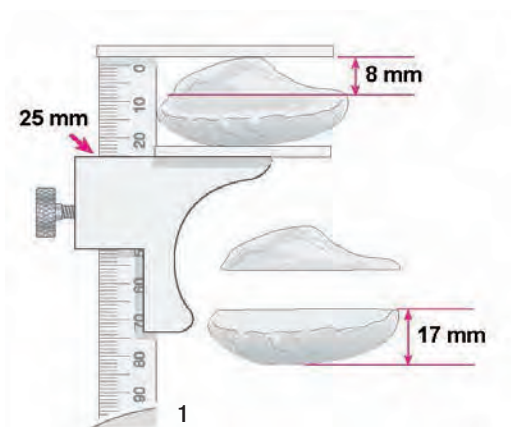

Patella size	Patella-Ø	Patella height
1	25 mm	7 mm
2	28 mm	8 mm
3	31 mm	9 mm
4	34 mm	10 mm

Preparation for Patella Component

The patella surface can be prepared using the onlay technique by resecting with an oscillating saw or by reaming.

Sizing

A patella sizing template (340-010) corresponding to the implants is available (2.1)

The template is selected that most adequately covers the articular surface without any overhang. If bone is deficient on the lateral side, the next smaller size is selected, but positioned slightly to the medial side to enhance patellar tracking (2.2).

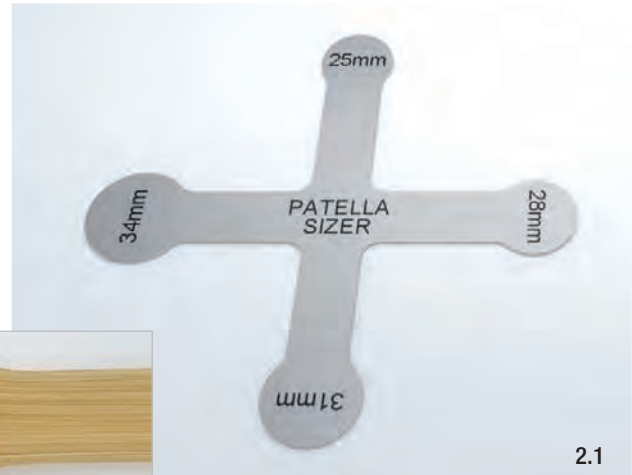

2.1



2.2

Option: Resection

The height of the bone to be resected can be adjusted using the height stylus (a) on the resection clamp (340-006) (3).

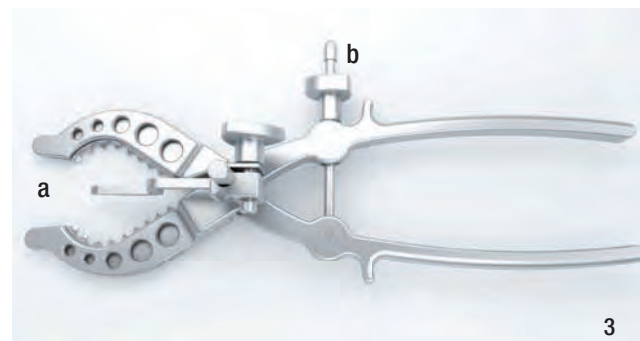

3

In doing this, it is important to ensure that the remaining patella is sufficiently thick. The patella is held using the toothed jaws. The sectional plane must lie parallel to the extended patellar tendon and the height calliper must lie on the bone. In order to clamp the patella firmly, the resection clamp (340-006) is compressed firmly and fixed using the lateral setting screw (b) (4).

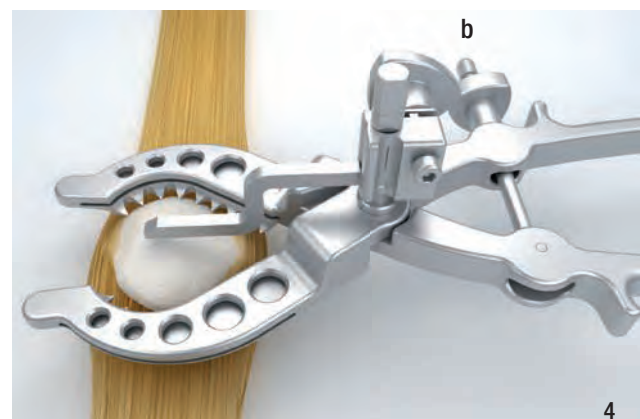

4

The resection is carried out using an oscillating saw with a 1.27 mm thick sawblade. The saw is guided using the cutting slots of the resection clamp (340-006) (5).



Option: Reaming

Reaming Preparation

The reaming guide (340-025 to 340-034) (c) of the appropriate size is inserted into the patella holding clamp (340-005) (d) (6).

INFORMATION:

Press the button on the side to insert and remove the guide.

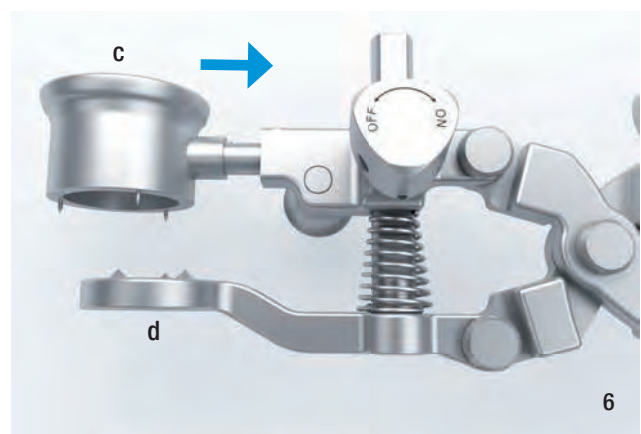

A ratchet can be activated on the patella holding clamp (340-005) with the retaining screw (e). By turning the screw to "ON" the clamp is held shut. By turning the screw to "OFF", the ratchet is released (7).



Following removal of the peripheral osteophytes, the patella is clamped with the patella holding clamp (340-005), aiming at the most central position possible (8). Good fixation is achieved when the spikes on the guide grip into the bone.



Reaming

The patella reamer is selected (f) to match the implant size which was previously determined and the corresponding reaming guide (9).

The patella reamer (340-125B to 340-134B) has a Hudson drill **B** connection for direct fixation with corresponding power tool connection. It is compatible with other machine systems by using an adapter for snap lock chuck.

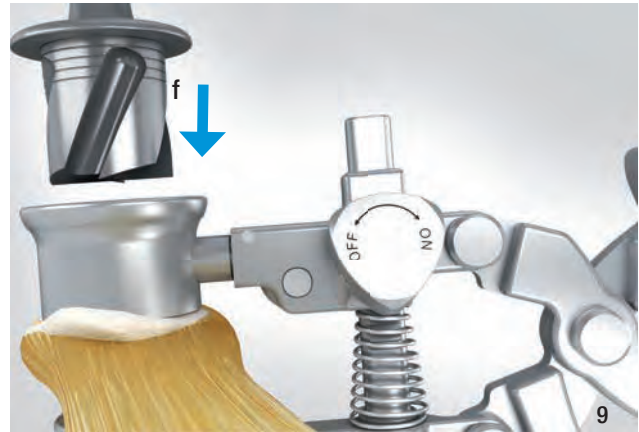

The patella surface is prepared using the patella reamer (f). Reaming depth is verified by means of the mechanical stop on the reamer. In addition, there are marking grooves at 2 mm intervals. The maximum reaming depth is reached when the reamer collar makes contact with the reaming guide (10).



Fixation Hole Drilling

If the sawblade resection option is selected, the patella is to be fixed with the patella holding clamp (340-005) as follows:

- Insert the patella reaming guide into the patella holding clamp,
- ratchet function “ON”,
- clamp the patella firmly.

Following description is for options „resection“ as well as „reaming“.

Insert the patella drill guide (340-225 to 340-234) (g) for the anchoring three holes which corresponds to the chosen implant size into the reaming guide (340-025 to 340-034) (11).

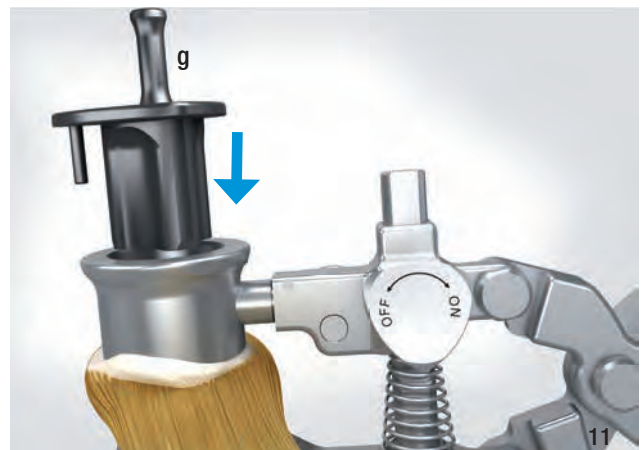

In doing so, ensure that the guide pin on the drill guide lies in the opening made for it in the reaming guide. Using the Ø 6.3 mm patella drill (340-306B) (h) three holes guided by the drill guide are drilled. The patella drill is inserted until stop (12).

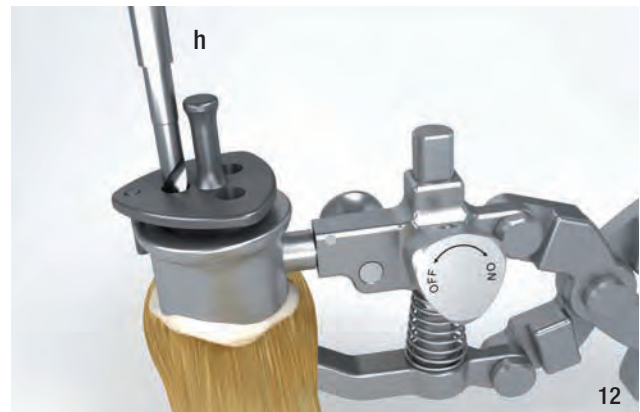

Patella Implantation

The reaming guide is removed from the patella holding clamp (340-005). The patella pusher inserter (340-009) (i) is pressed into the patella pusher attachment (340-007) (j) (13+14) and the pusher inserter is then inserted into the holding clamp (340-005) (15). Appropriate patella tracking can be assessed using patella trial prostheses (340-325 to 340-334).

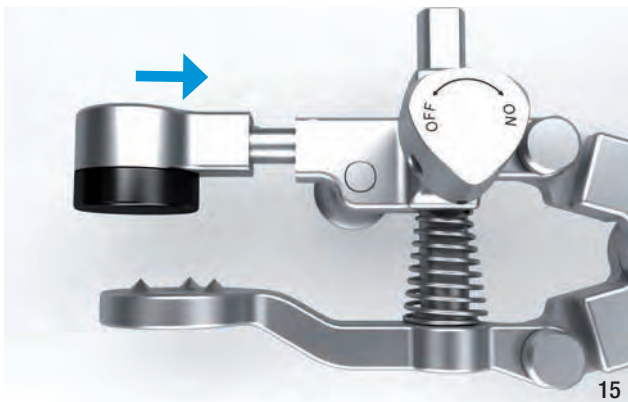
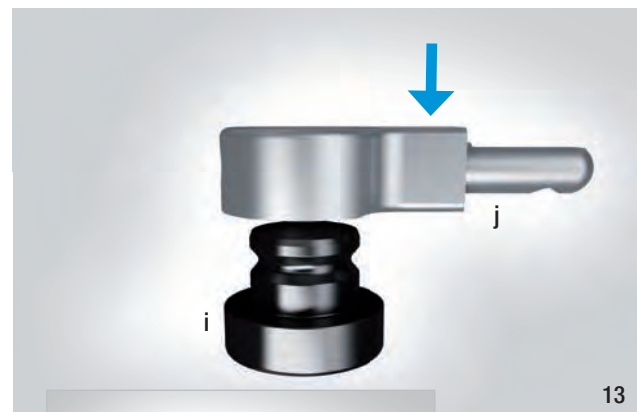

Following extensive rinsing and removal of all impeding soft tissue, the bone cement is applied to the back of the implant, and the patella component is placed by hand and pressed on using the patella holding clamp (340-005) with the patella pusher inserter (340-009) (16).



CAUTION:

Prepare the bone cement according to the manufacturer's instructions.

Ensure that excess bone cement is completely removed and that no loose particles of bone cement remain in the joint.

Variety of Assembly 1

Centralizers

Modular Stems
cementless + cemented

Femoral Components
intracondylar or distal femoral replacement

Connection Components
hinged or rotational version, incl. tibial plateau (UHMWPE)

Proximal Tibial Replacement
modular

Support Ring

Modular Stems
cementless + cemented

Centralizers

Variety of Assembly 2

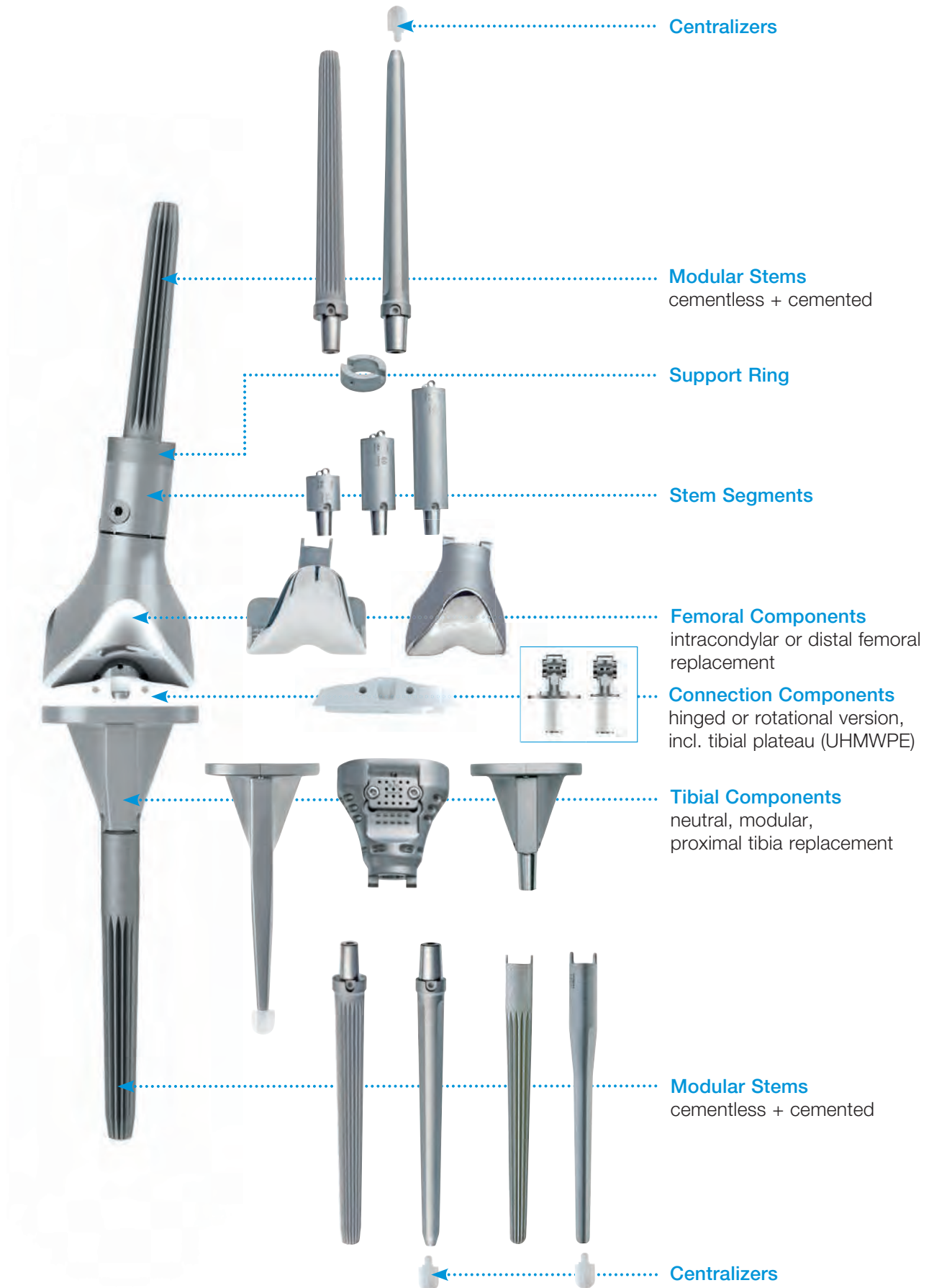

Variety of Assembly 3

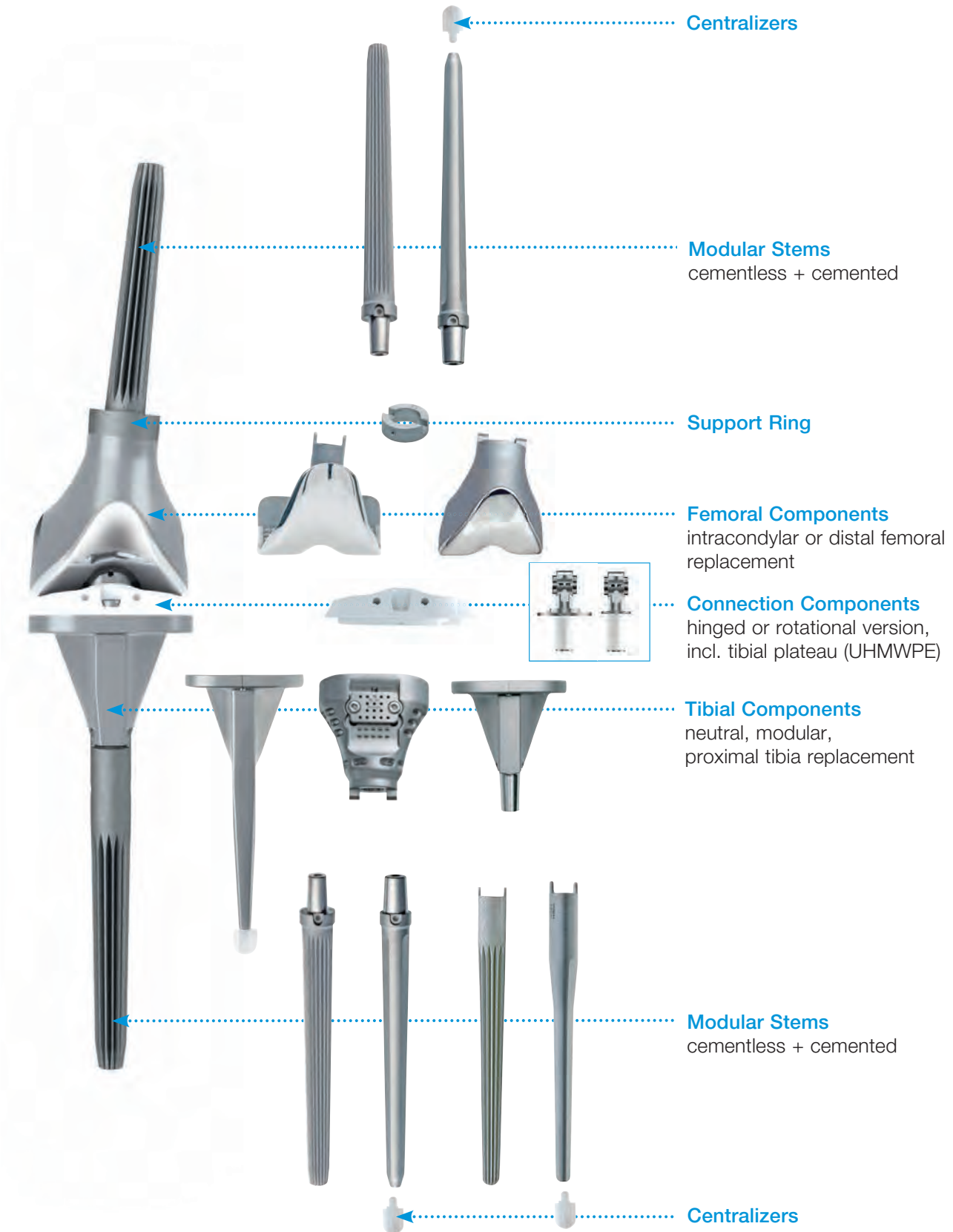



Variety of Assembly 4

Neck Segments
with expansion bolts and proximal spacers

Push-through Stems
for total femur replacement

Support Ring

Stem Segments

Femoral Components
intracondylar or distal femoral replacement

Connection Components
hinged or rotational version, incl. tibial plateau (UHMWPE)

Tibial Components
neutral, modular, proximal tibia replacement

Modular Stems
cementless + cemented

Centralizers

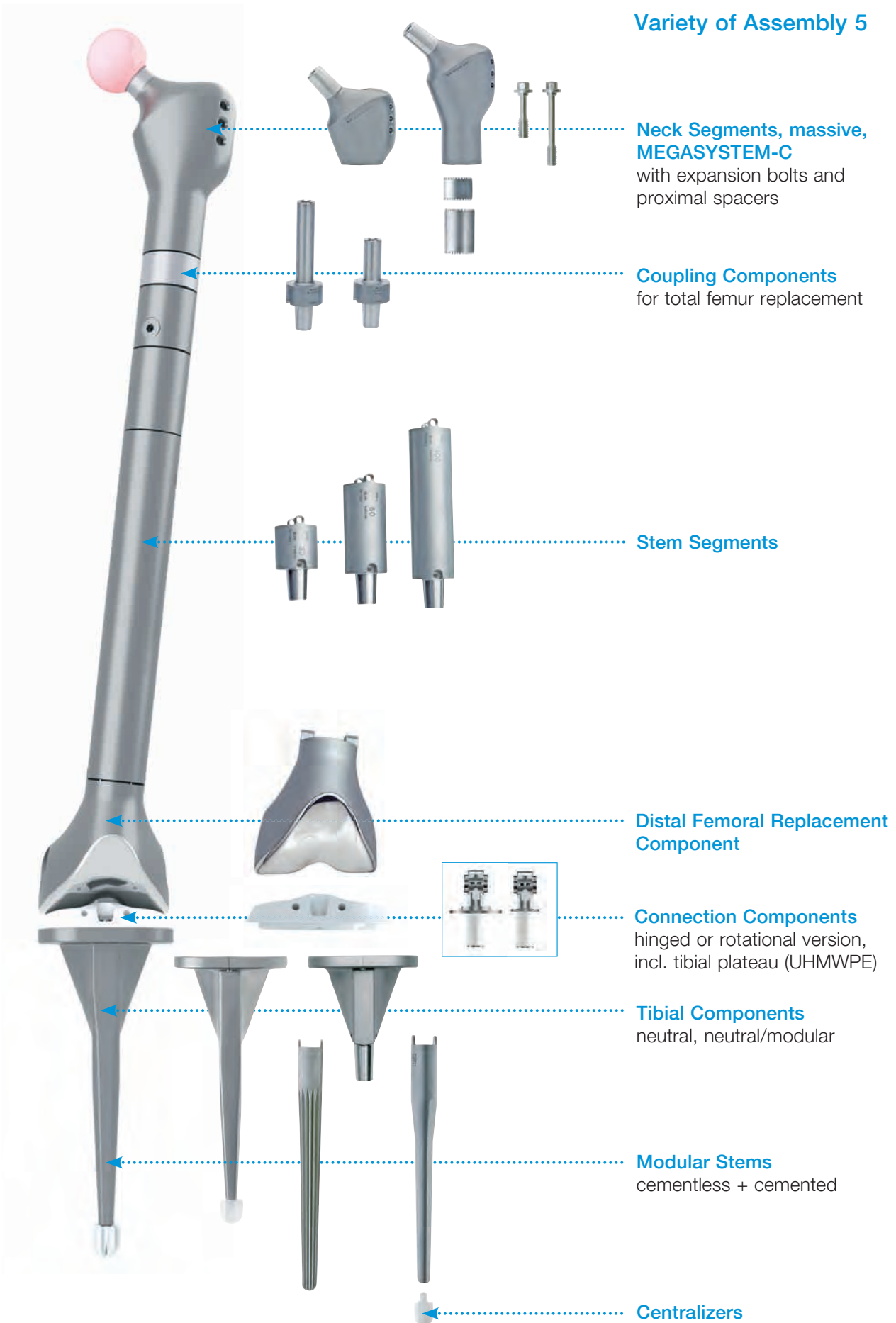

Variety of Assembly 6

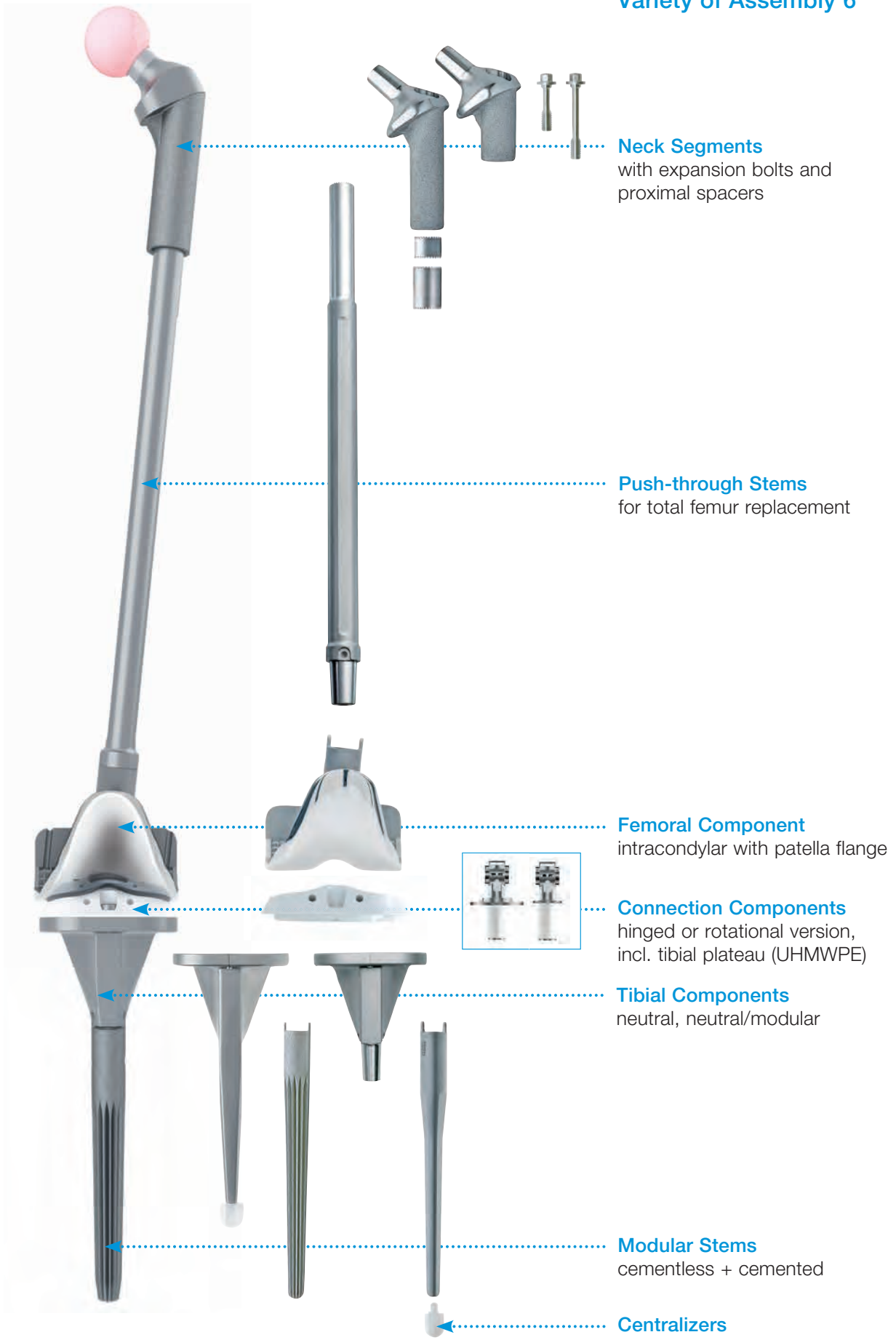

Variety of Assembly 7

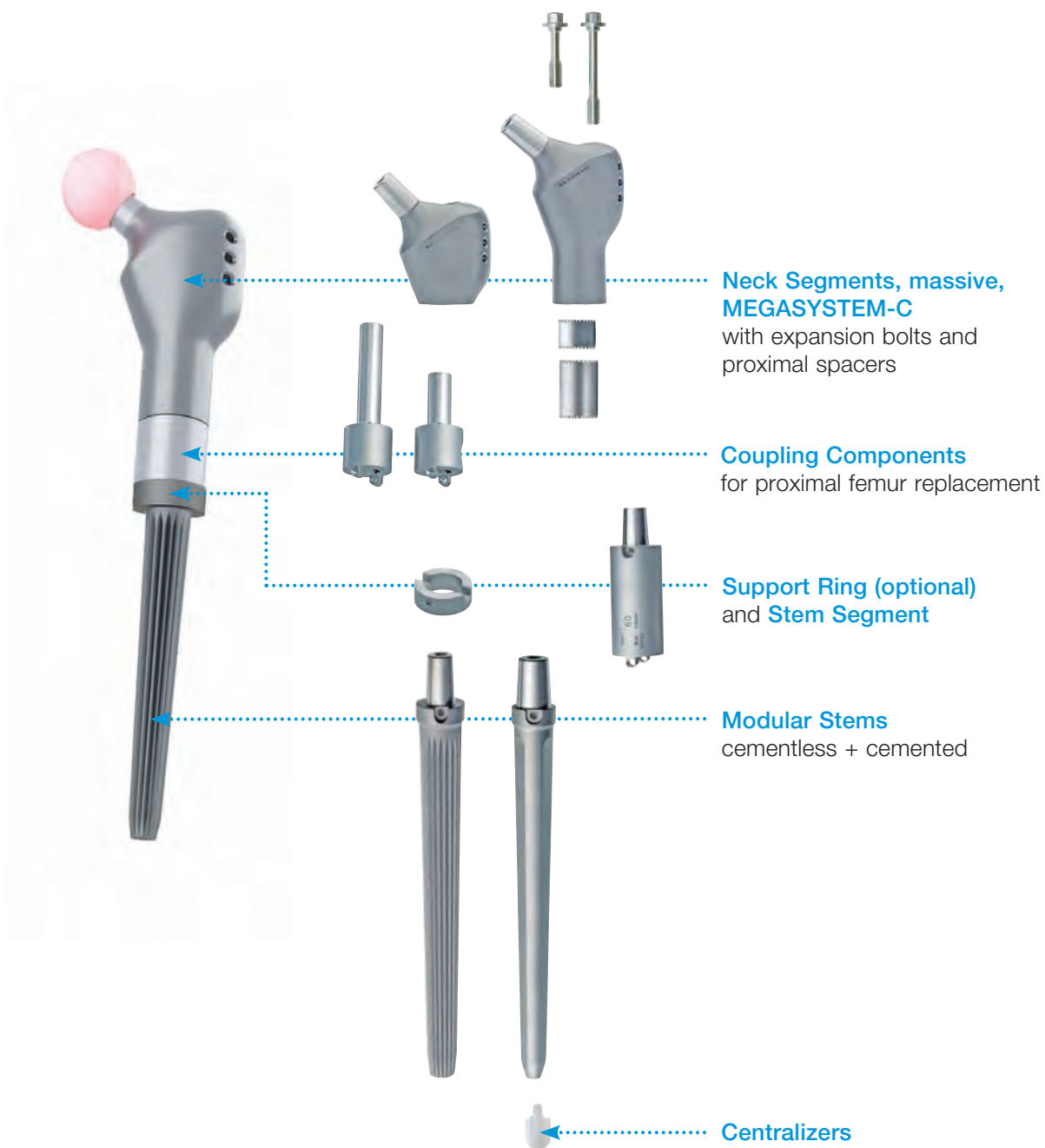

Variety of Assembly 8

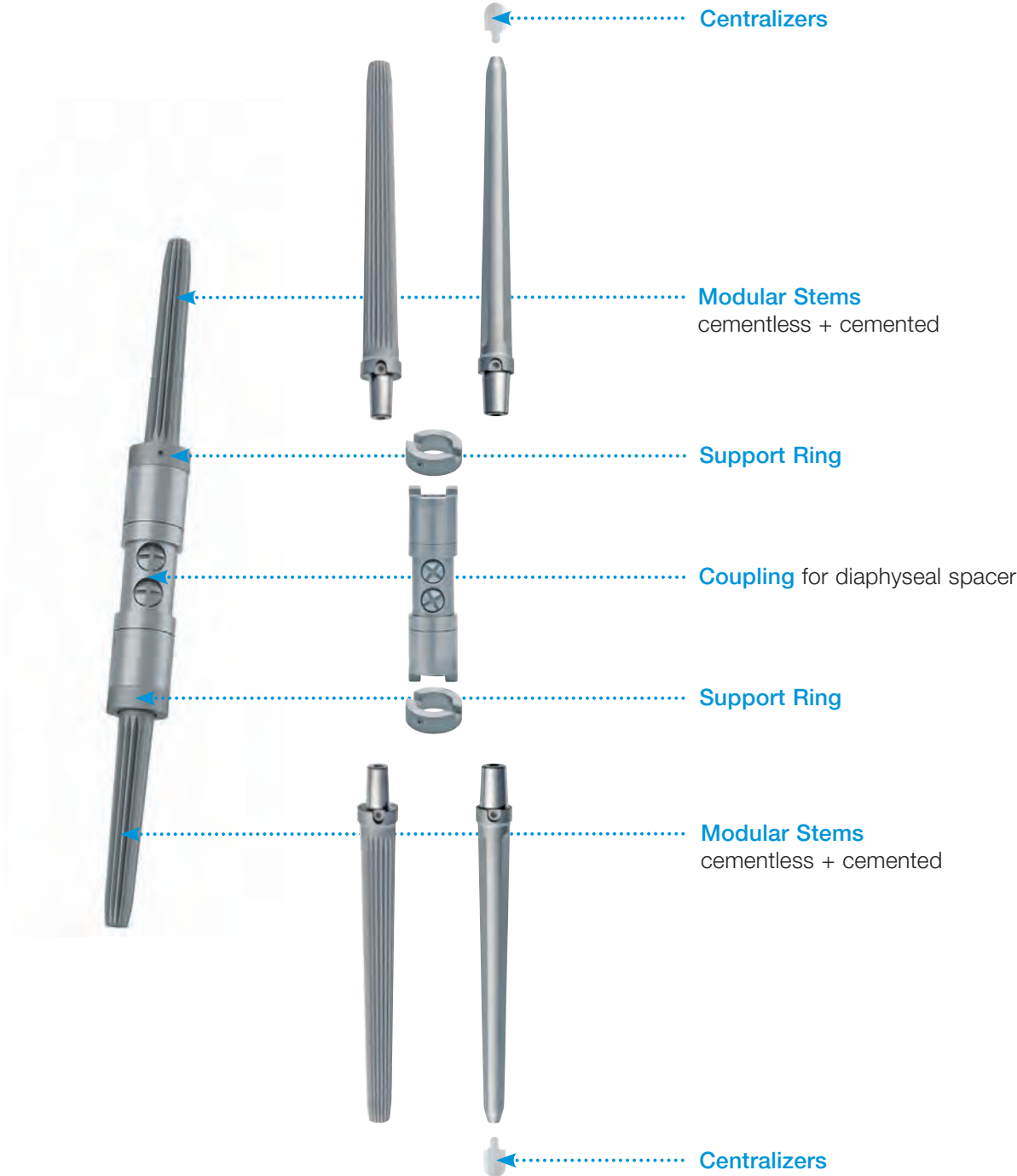

Neck Segments



Neck Segments, massive, MEGASYSTEM-C

MAT Tilastan, CoCrMo

REF	Length	CCD angle
15-8503/35	65 mm	135°
15-8503/26	65 mm	126°
15-8504/35	35 mm	135°
15-8504/26	35 mm	126°



Neck Segments, microporous

MAT Tilastan

without collar REF	with collar REF	Length	CCD angle
172-964/35	172-960/35	65 mm	135°
172-964/26	172-960/26	65 mm	126°
172-965/35	172-961/35	35 mm	135°
172-965/26	172-961/26	35 mm	126°

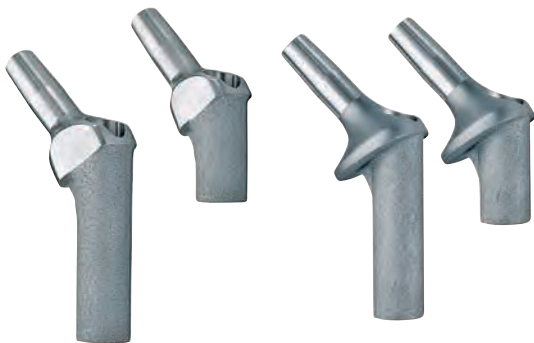

Neck Segments XXL, 40 mm offset, microporous

MAT Tilastan

without collar REF	with collar REF	Length	CCD angle
172-984/35	172-980/35	65 mm	135°
172-984/26	172-980/26	65 mm	126°
172-985/35	172-981/35	35 mm	135°
172-985/26	172-981/26	35 mm	126°

Neck Segments with Suture Holes

MAT Tilastan



microporous REF	Length	CCD angle	Offset
99-0984/30	65 mm	126°	31 mm
99-0984/32	35 mm	126°	31 mm



Neck Segments XXL with Suture Holes

MAT Tilastan

microporous REF	Length	CCD angle	Offset
99-0984/26	65 mm	126°	40 mm
99-0984/28	35 mm	126°	40 mm

Proximal Spacers and Expansion Bolts

Proximal Spacers

MAT CoCrMo

REF	Length
172-950/10	10 mm
172-950/20	20 mm



Expansion Bolts

MAT CoCrMo

REF	Length
172-947/38	41 mm
172-947/58	61 mm



Possible Combinations:

Neck Segments Length (mm)	Proximal Spacers		Extension mm	Expansion Bolt Length (mm)
	10 mm	20 mm		
65	-	-	0	41
65	10	-	10	41
65	-	20	20	61
65	10	20	30	61
35 ¹⁾	-	-	-	41

1) Combination with proximal spacer(s) not possible.



Prosthesis Heads

Prosthesis Heads A, Taper 12/14 mm



BioloX delta*

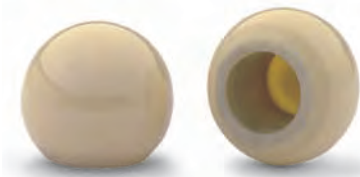

BioloX forte*

Head-Ø	MAT BioloX delta*	MAT BioloX forte*	Neck length
	REF	REF	
28 mm	128-791/01	128-928/01	S (-3.5 mm)
28 mm	128-791/02	128-928/02	M (0 mm)
28 mm	128-791/03	128-928/03	L (+3.5 mm)
32 mm	128-792/01	128-932/01	S (-4 mm)
32 mm	128-792/02	128-932/02	M (0 mm)
32 mm	128-792/03	128-932/03	L (+4 mm)
32 mm	128-792/04		XL (+7 mm)
36 mm	128-793/01	128-936/01	S (-4 mm)
36 mm	128-793/02	128-936/02	M (0 mm)
36 mm	128-793/03	128-936/03	L (+4 mm)
36 mm	128-793/04		XL (+8.0 mm)

All BIOLOX forte* and BIOLOX delta* components are compatible with each other.

(S) short (M) medium (L) long (XL) extra long

* BIOLOX delta and BIOLOX forte are products from CeramTec GmbH, Plochingen, Germany

Prosthesis Heads B, Taper 12/14 mm



CoCrMo

Head-Ø	MAT CoCrMo (Cast alloy)	MAT CoCrMo (Forge alloy)	Neck length
	REF	REF	
28 mm	128-828/01	198-828/01	S (-3.5 mm)
28 mm	128-828/02	198-828/02	M (0 mm)
28 mm	128-828/03	198-828/03	L (+3.5 mm)
28 mm		198-828/04	XL (+7 mm)
28 mm	128-828/04		XL (+10.5 mm)
28 mm		198-828/05	XXL (+10.5 mm)
32 mm	128-832/01	198-832/01	S (-3.5 mm)
32 mm	128-832/02	198-832/02	M (0 mm)
32 mm	128-832/03	198-832/03	L (+3.5 mm)
32 mm	128-832/04	198-832/04	XL (+7 mm)
36 mm	128-836/01	198-836/01	S (-4 mm)
36 mm	128-836/02	198-836/02	M (0 mm)
36 mm	128-836/03	198-836/03	L (+4 mm)
36 mm	128-836/04	198-836/04	XL (+8 mm)

(S) short (M) medium (L) long (XL) extra long (XXL) extra extra long

Stem Components

Push-through Stems for total femur replacement

MAT CoCrMo, UHMWPE



REF	Ø	Length
15-8523/70	14 mm	120 mm
15-8523/71	14 mm	160 mm
15-8523/72	14 mm	200 mm
15-8523/73	14 mm	240 mm
15-8523/74	14 mm	280 mm
15-8523/75	14 mm	320 mm
15-8523/76	14 mm	360 mm
15-8522/70	16 mm	120 mm
15-8522/71	16 mm	160 mm
15-8522/72	16 mm	200 mm
15-8522/73	16 mm	240 mm
15-8522/74	16 mm	280 mm
15-8522/75	16 mm	320 mm
15-8522/76	16 mm	360 mm

15-8522/65

Coupling for diaphyseal spacer, the coupling is intended for diaphyseal replacement, length (L) 103 mm

MAT Tilastan, CoCrMo, UHMWPE

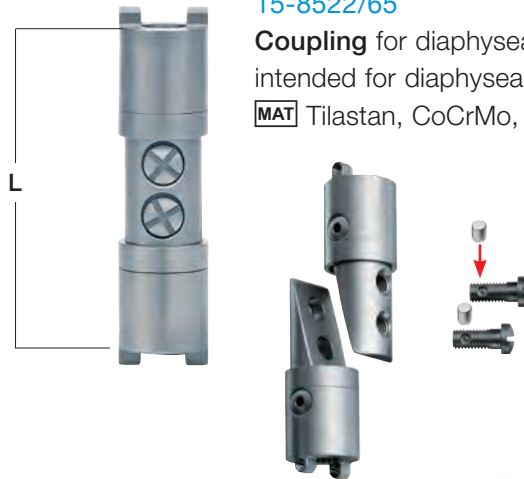

Note for lock bolts:
Bevelled side is inserted first!



Knee Fusion Nail – Coupling Components

modular, 10/12 taper, length (L) 70 mm

MAT CoCrMo, UHMWPE

REF	Side
15-0028/07	left
15-0028/08	right

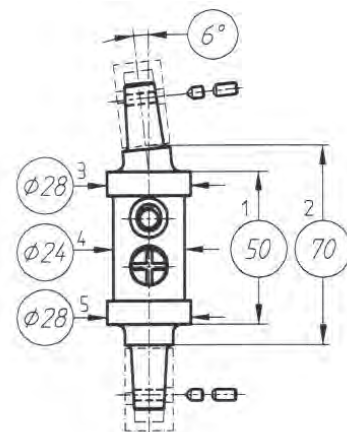

Further information can be found in the product-specific surgical technique for Endo-Model Knee Fusion Nail SK.

Stem Components

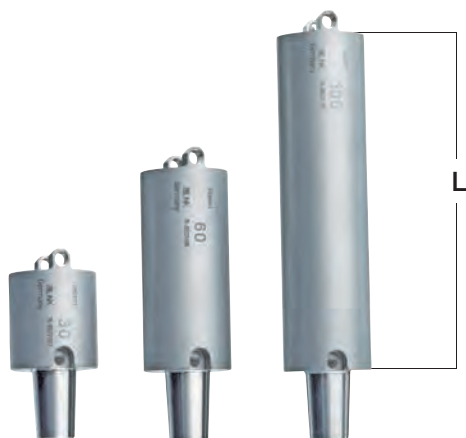

Stem Segments, Ø 28 mm

MAT Tilastan, CoCrMo

REF	Length (L)
15-8522/02	30 mm
15-8522/04	40 mm
15-8522/06	50 mm
15-8522/08	60 mm
15-8522/10	100 mm
15-8522/12	150 mm
15-8522/14	200 mm
15-8522/16	250 mm

Coupling Components for total femur (A) and proximal femur replacement (B)

MAT CoCrMo

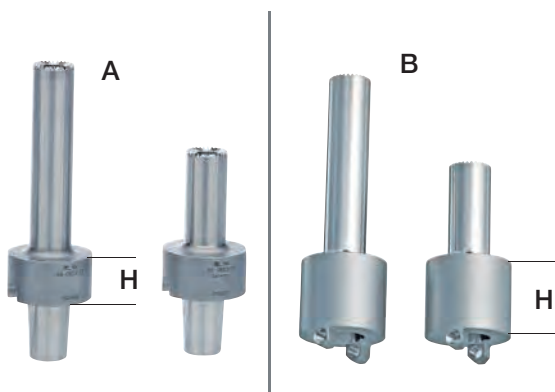

REF	For replacement:	Height (H)
15-8522/24	Total femur replacement (A) short	20 mm
15-8522/26	Total femur replacement (A) long	20 mm
15-8522/28	Proximal femur replacement (B) short	30 mm
15-8522/30	Proximal femur replacement (B) long	30 mm

Support Ring, height (H) 10 mm

MAT Tilastan, CoCrMo

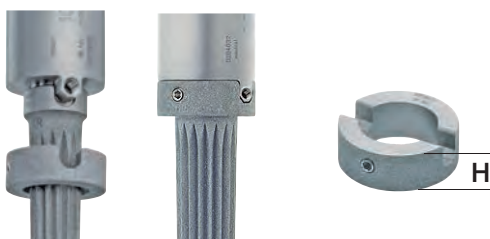

REF	For stem-Ø	Height (H)
15-8502/66	up to Ø 18 mm	10 mm

Note:
After positioning the support ring,
the set screw must be fixed!

Terminals oval, height (H) 10 mm

MAT Tilastan

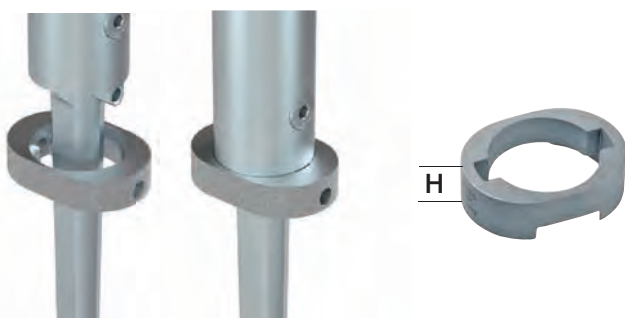

REF	Dimensions:
15-8512/83	26 x 34 mm, 24 mm Inner-Ø
15-8512/84	30 x 44 mm, 24 mm Inner-Ø
15-8512/85	34 x 48 mm, 24 mm Inner-Ø

Note:
No set screw used!



Interprosthetic Sleeves (RescueSleeve)

Custom-made prostheses



- Individually designed sleeves to connect a proximal and distal stem (twin sleeve)
- Proven^{6,7}, ultra-strong and compact LINK PocketBridget technology
- Safe stem fixation in bone cement
- A variety of designs for specific indications – stem anchoring or stem attachment MEGASYSTEM-C

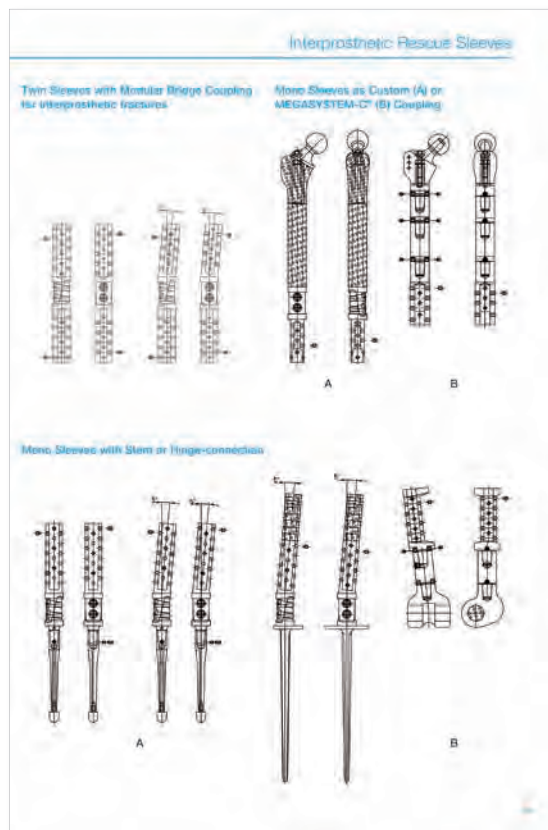

⁶ Duda, Georg et al „Dynamic Examination of an Arthrodesis Nail’s Taper Connection“, TU Hamburg/Harburg, Dept. of Biomechanics, Prof. Dr. E. Schneider, 02/94

⁷ Weiser, L. et al „Interposition sleeve as treatment option for interprosthetic fractures of the femur; a biomechanical in vitro assessment“, Intern. Orthop (SICOT), DOI 10.1007/s00264-015-2788-5

These implants are available as custom-made products.



Interprosthetic Sleeves (RescueSleeve)
Custom-made prostheses

Joint Components Endo-Model SL for Rotating and Non-Rotating Hinge Knee

All size-specific implants for the Endo-Model SL only allow a combination of the same size (applies from page 58 to page 64)



Femoral Components, modular, intracondylar

MAT CoCrMo, UHMWPE

REF	Size	Side	M/L – A/P
16-2821/21	small (S)	right	63 – 57 mm
16-2821/22	small (S)	left	63 – 57 mm
16-2823/21	medium (M)	right	69 – 62 mm
16-2823/22	medium (M)	left	69 – 62 mm
16-2825/21	large (L)	right	72.5 – 65 mm
16-2825/22	large (L)	left	72.5 – 65 mm

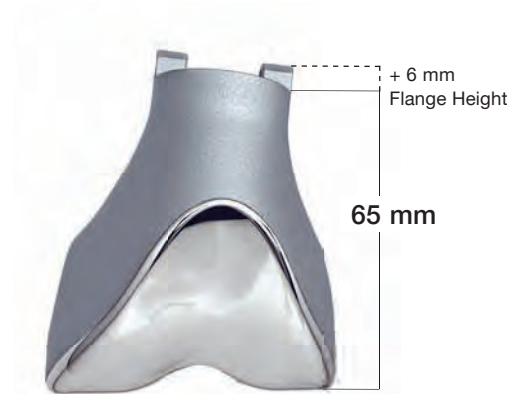

Distal Femoral Replacement Components, slim

MAT CoCrMo, UHMWPE

REF	Size	Side	M/L – A/P
16-2853/31	small (S)	right	60 – 57 mm
16-2853/32	small (S)	left	60 – 57 mm
16-2855/31	medium (M)	right	65 – 62 mm
16-2855/32	medium (M)	left	65 – 62 mm
16-2857/31	large (L)	right	75 – 65 mm
16-2857/32	large (L)	left	75 – 65 mm

Joint Components Endo-Model SL for Rotating and Non-Rotating Hinge Knee

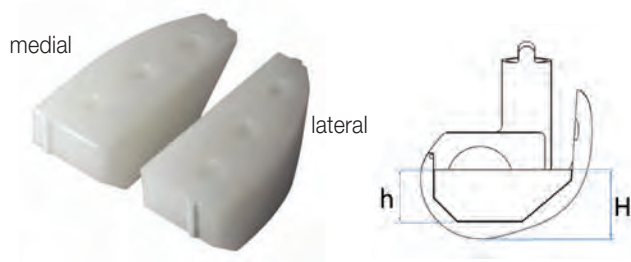

Femoral Segments for femoral components,
to replace distal condyles

MAT UHMWPE

REF	Size	Side		h	H
15-8519/01	small	right	medial	18 mm	25 mm
15-8519/02	medium	right	medial	19 mm	25 mm
15-8519/03	large	right	medial	17 mm	25 mm
15-8519/11	small	right	lateral	18 mm	25 mm
15-8519/12	medium	right	lateral	19 mm	25 mm
15-8519/13	large	right	lateral	17 mm	25 mm
15-8520/01	small	left	medial	18 mm	25 mm
15-8520/02	medium	left	medial	19 mm	25 mm
15-8520/03	large	left	medial	17 mm	25 mm
15-8520/11	small	left	lateral	18 mm	25 mm
15-8520/12	medium	left	lateral	19 mm	25 mm
15-8520/13	large	left	lateral	17 mm	25 mm

Joint Components Endo-Model SL for Rotating and Non-Rotating Hinge Knee

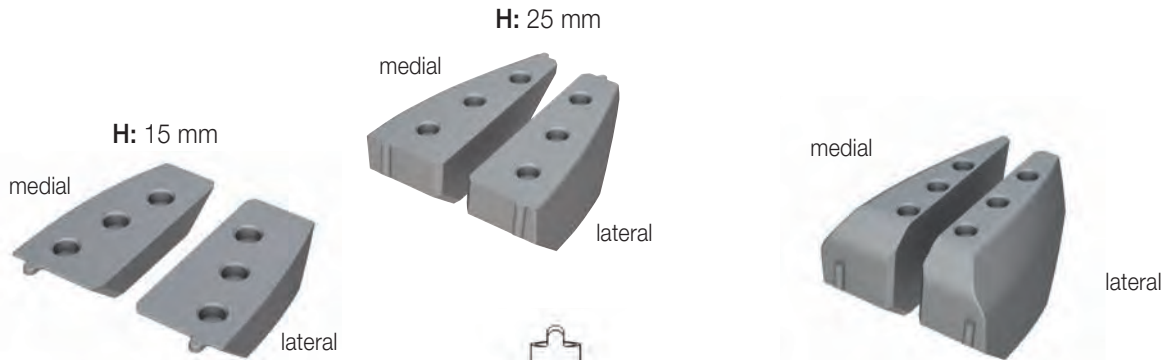

Femoral Segments, cementless for femoral components, to replace distal condyles

MAT Tilastan

Femoral Segments, full, cementless for femoral components, to replace distal condyles

MAT Tilastan

REF	h	H	Size	Side	
15-8570/01	8 mm	15 mm	small	right	medial
15-8570/02	9 mm	15 mm	medium	right	medial
15-8570/03	7 mm	15 mm	large	right	medial
15-8570/11	8 mm	15 mm	small	right	lateral
15-8570/12	9 mm	15 mm	medium	right	lateral
15-8570/13	7 mm	15 mm	large	right	lateral
15-8571/01	8 mm	15 mm	small	left	medial
15-8571/02	9 mm	15 mm	medium	left	medial
15-8571/03	7 mm	15 mm	large	left	medial
15-8571/11	8 mm	15 mm	small	left	lateral
15-8571/12	9 mm	15 mm	medium	left	lateral
15-8571/13	7 mm	15 mm	large	left	lateral
15-8517/01	18 mm	25 mm	small	right	medial
15-8517/02	19 mm	25 mm	medium	right	medial
15-8517/03	17 mm	25 mm	large	right	medial
15-8517/11	18 mm	25 mm	small	right	lateral
15-8517/12	19 mm	25 mm	medium	right	lateral
15-8517/13	17 mm	25 mm	large	right	lateral
15-8518/01	18 mm	25 mm	small	left	medial
15-8518/02	19 mm	25 mm	medium	left	medial
15-8518/03	17 mm	25 mm	large	left	medial
15-8518/11	18 mm	25 mm	small	left	lateral
15-8518/12	19 mm	25 mm	medium	left	lateral
15-8518/13	17 mm	25 mm	large	left	lateral

REF	Size	Side	
15-8572/01	small	right	medial
15-8572/02	medium	right	medial
15-8572/03	large	right	medial
15-8572/11	small	right	lateral
15-8572/12	medium	right	lateral
15-8572/13	large	right	lateral
15-8573/01	small	left	medial
15-8573/02	medium	left	medial
15-8573/03	large	left	medial
15-8573/11	small	left	lateral
15-8573/12	medium	left	lateral
15-8573/13	large	left	lateral

Joint Components Endo-Model SL for Rotating and Non-Rotating Hinge Knee

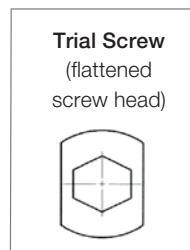
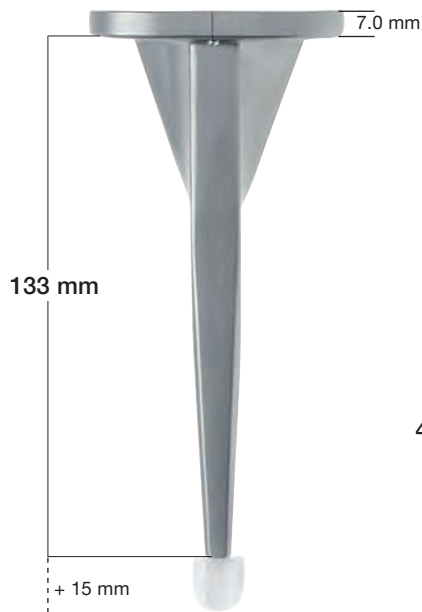

Tibial Components, neutral

MAT CoCrMo, UHMWPE

REF	Size	A x B
16-2817/02	small (S)	60 x 45 mm
16-2817/05	medium (M)	65 x 45 mm
16-2817/07	large (L)	75 x 48 mm

Tibial Components System SL, modular, neutral

MAT CoCrMo, UHMWPE

REF	Size	A x B
16-2817/32	small (S)	60 x 45 mm
16-2817/35	medium (M)	65 x 45 mm
16-2817/37	large (L)	75 x 48 mm

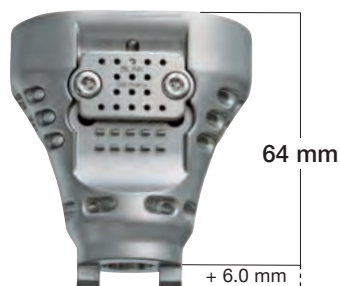
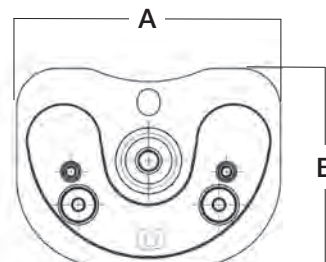

Proximal Tibia Replacement Components, modular, neutral

MAT Tilastan, UHMWPE

REF	Size	A x B
16-2849/22	small (S)	60 x 45 mm
16-2849/25	medium (M)	65 x 45 mm
16-2849/27	large (L)	75 x 48 mm

Joint Components Endo-Model SL for Rotating and Non-Rotating Hinge Knee

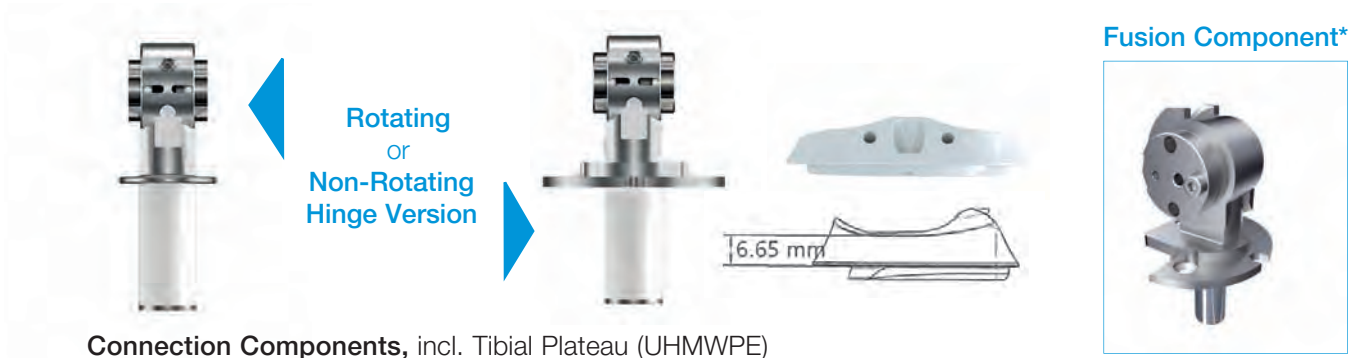

Connection Components, incl. Tibial Plateau (UHMWPE)

REF	Rotating Hinge MAT CoCrMo, UHMWPE	REF	Non-Rotating Hinge MAT CoCrMo, UHMWPE	Arthrodesis Fusion Version* MAT CoCrMo, UHMWPE
16-2840/02	small (S) neutral	16-2841/02	small (S) neutral	Knee fusion option for in-situ femoral and tibial components.
16-2840/05	medium (M) neutral	16-2841/05	medium (M) neutral	
16-2840/07	large (L) neutral	16-2841/07	large (L) neutral	

* only available as custom-made implant

Replacement Sets

Replacement Set: Bearing Boxes for Endo-Model SL

MAT UHMWPE

REF	Side	Size
16-2011/21	right	small
16-2011/22	left	small
16-2013/21	right	medium
16-2013/22	left	medium
16-2015/21	right	large
16-2015/22	left	large



Proximal Tibial Spacers, Tilastan and UHMWPE
for Endo-Model SL Rotating and Non-Rotating Hinge Knee



Proximal Tibial Spacers, full,
for right and left, incl. 2 countersunk screws,
wrench size 2.5 mm

MAT Tilastan

REF	Size	H Height	Width
16-2910/05	small	5 mm	60 mm
16-2910/10	small	10 mm	60 mm
16-2910/15	small	15 mm	60 mm
16-2920/05	medium	5 mm	65 mm
16-2920/10	medium	10 mm	65 mm
16-2920/15	medium	15 mm	65 mm
16-2930/05	large	5 mm	75 mm
16-2930/10	large	10 mm	75 mm
16-2930/15	large	15 mm	75 mm

Proximal Tibial Spacers, full,
for right and left

MAT UHMWPE

REF	Size	H Height	Width
16-3000/05	small	5 mm	60 mm
16-3000/10	small	10 mm	60 mm
16-3000/15	small	15 mm	60 mm
16-3010/05	medium	5 mm	65 mm
16-3010/10	medium	10 mm	65 mm
16-3010/15	medium	15 mm	65 mm
16-3020/05	large	5 mm	75 mm
16-3020/10	large	10 mm	75 mm
16-3020/15	large	15 mm	75 mm

Note:

Proximal tibial spacers may not be combined!

Proximal Tibial Spacers, Tilastan

for Endo-Model SL Rotating and Non-Rotating Hinge Knee

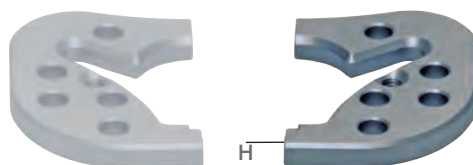

Proximal Tibial Spacers, half,

lateral and medial usable, incl. 1 countersunk screw,
wrench size 2.5 mm

MAT Tilastan

REF	Size	H Height
16-2950/05	small	5 mm
16-2950/10	small	10 mm
16-2950/15	small	15 mm
16-2960/05	medium	5 mm
16-2960/10	medium	10 mm
16-2960/15	medium	15 mm
16-2970/05	large	5 mm
16-2970/10	large	10 mm
16-2970/15	large	15 mm

Note:

**Proximal tibial spacers may not be combined
with each other!**

Modular Stems with male taper

Modular Stems* with male taper (for 6 mm flanges)

MAT Tilastan



Cementless					
REF	Stem length L 100 mm	REF	Stem length L 130 mm	REF	Stem length L 160 mm
15-8524/50	Ø 12/09 mm	15-8523/50	Ø 12/08 mm	15-8522/50	Ø 12/07 mm
15-8524/51	Ø 13/10 mm	15-8523/51	Ø 13/09 mm	15-8522/51	Ø 13/08 mm
15-8524/52	Ø 14/11 mm	15-8523/52	Ø 14/10 mm	15-8522/52	Ø 14/09 mm
15-8524/53	Ø 15/12 mm	15-8523/53	Ø 15/11 mm	15-8522/53	Ø 15/10 mm
15-8524/54	Ø 16/13 mm	15-8523/54	Ø 16/12 mm	15-8522/54	Ø 16/11 mm
15-8524/55	Ø 17/14 mm	15-8523/55	Ø 17/13 mm	15-8522/55	Ø 17/12 mm
15-8524/56	Ø 18/15 mm	15-8523/56	Ø 18/14 mm	15-8522/56	Ø 18/13 mm
15-8524/57	Ø 19/16 mm	15-8523/57	Ø 19/15 mm	15-8522/57	Ø 19/14 mm
15-8524/58	Ø 20/17 mm	15-8523/58	Ø 20/16 mm	15-8522/58	Ø 20/15 mm
15-8524/59	Ø 21/18 mm	15-8523/59	Ø 21/17 mm	15-8522/59	Ø 21/16 mm
15-8524/60	Ø 22/19 mm	15-8523/60	Ø 22/18 mm	15-8522/60	Ø 22/17 mm
15-8524/61	Ø 23/20 mm	15-8523/61	Ø 23/19 mm	15-8522/61	Ø 23/18 mm
15-8524/62	Ø 24/21 mm	15-8523/62	Ø 24/20 mm	15-8522/62	Ø 24/19 mm

Modular Stems* with male taper (for 6 mm flanges)

MAT CoCrMo



Cemented					
REF	Stem length L 100 mm	REF	Stem length L 130 mm	REF	Stem length L 160 mm
15-8524/40	Ø 12/09 mm	15-8523/40	Ø 12/08 mm	15-8522/40	Ø 12/07 mm
15-8524/42	Ø 14/11 mm	15-8523/42	Ø 14/10 mm	15-8522/42	Ø 14/09 mm
15-8524/44	Ø 16/13 mm	15-8523/44	Ø 16/12 mm	15-8522/44	Ø 16/11 mm

* These modular stems can be combined with:

- Coupling device to assemble a proximal partial femur replacement
- Femoral joint component, solid, or a stem segment attached to it to assemble a distal partial femur replacement
- Coupling device for the diaphyseal spacer
- Proximal tibial replacement

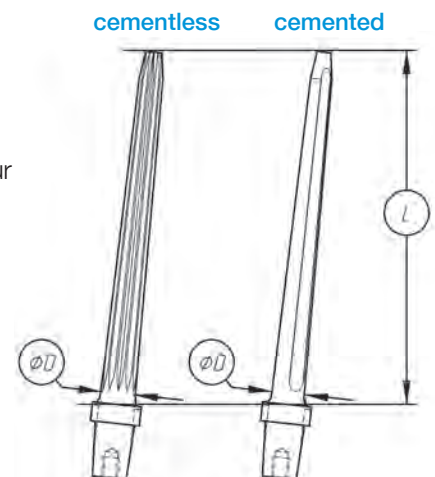

Modular Stems with female taper

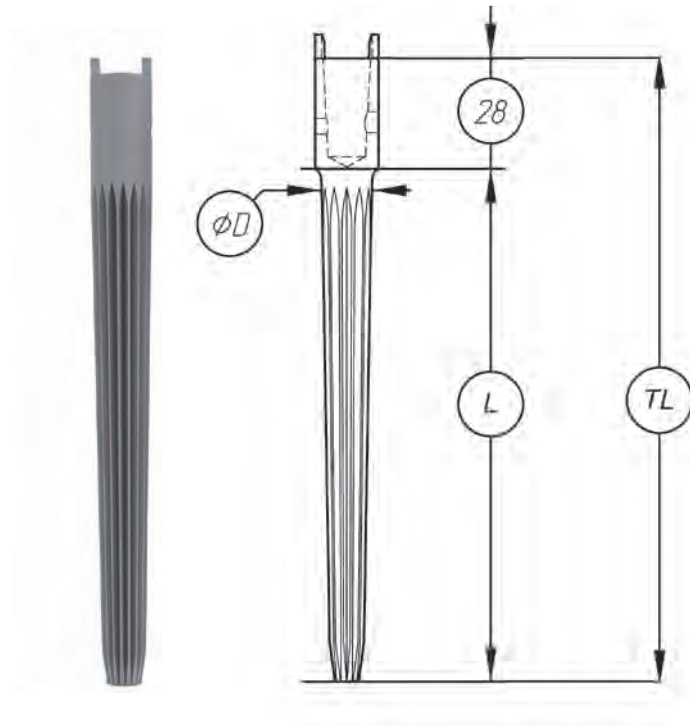

Modular Stems* with female taper (with 6 mm flanges)

MAT Tilastan

Cementless					
REF	Stem length L 100 mm	Total length TL 128 mm	REF	Stem length L 130 mm	Total length TL 158 mm
15-8517/50	Ø 12/09 mm		15-8516/50	Ø 12/08 mm	
15-8517/51	Ø 13/10 mm		15-8516/51	Ø 13/09 mm	
15-8517/52	Ø 14/11 mm		15-8516/52	Ø 14/10 mm	
15-8517/53	Ø 15/12 mm		15-8516/53	Ø 15/11 mm	
15-8517/54	Ø 16/13 mm		15-8516/54	Ø 16/12 mm	
15-8517/55	Ø 17/14 mm		15-8516/55	Ø 17/13 mm	
15-8517/56	Ø 18/15 mm		15-8516/56	Ø 18/14 mm	

REF	Stem length L 160 mm	Total length TL 188 mm
15-8515/50	Ø 12/07 mm	
15-8515/51	Ø 13/08 mm	
15-8515/52	Ø 14/09 mm	
15-8515/53	Ø 15/10 mm	
15-8515/54	Ø 16/11 mm	
15-8515/55	Ø 17/12 mm	
15-8515/56	Ø 18/13 mm	

Modular Stems with female taper

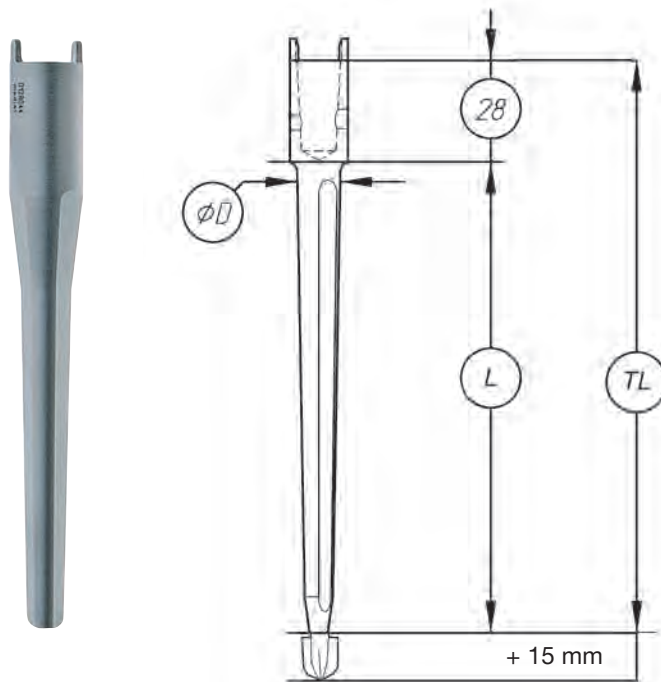

Modular Stems* with female taper (with 6 mm flanges),

MAT CoCrMo

Cemented					
REF	Stem length L 100 mm	Total length TL 128 mm	REF	Stem length L 130 mm	Total length TL 158 mm
15-8527/40	Ø 12/09 mm		15-8526/40	Ø 12/08 mm	
15-8527/42	Ø 14/11 mm		15-8526/42	Ø 14/10 mm	
15-8527/44	Ø 16/13 mm		15-8526/44	Ø 16/12 mm	

REF	Stem length L 160 mm	Total length TL 188 mm
15-8525/40	Ø 12/07 mm	
15-8525/42	Ø 14/09 mm	
15-8525/44	Ø 16/11 mm	

* These modular stems can be combined with: tibial components, neutral, modular (with 6 mm noses)

Modular Stems, short

MAT CoCrMo

Cemented	
REF	Stem length L
15-2950/01	50 mm
15-2950/02	80 mm

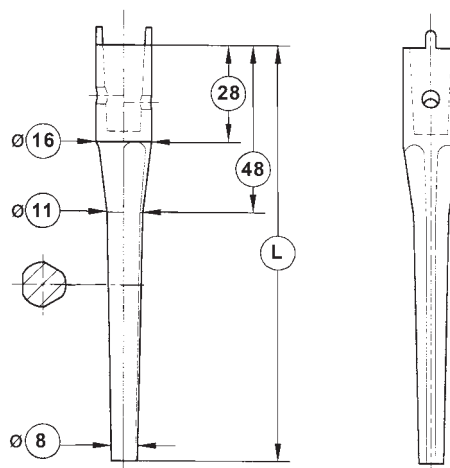

LINK MEGASYSTEM-C – Endo-Model Modular Joint Components with female taper

Condylar Replacement

Rotational Version,  CoCrMo, UHMWPE

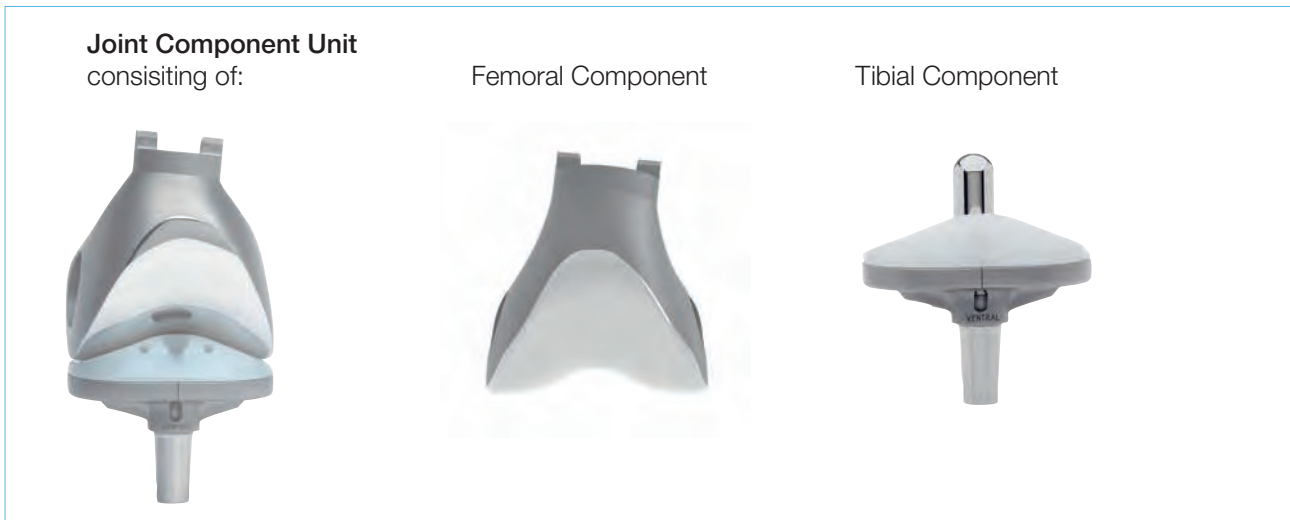

Intracondylar Version

Rotational Version,  CoCrMo, UHMWPE

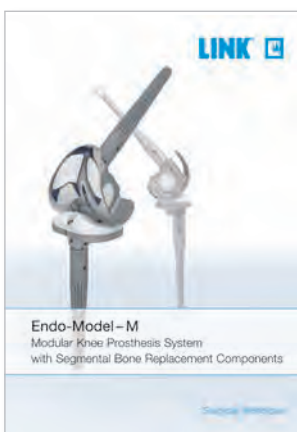
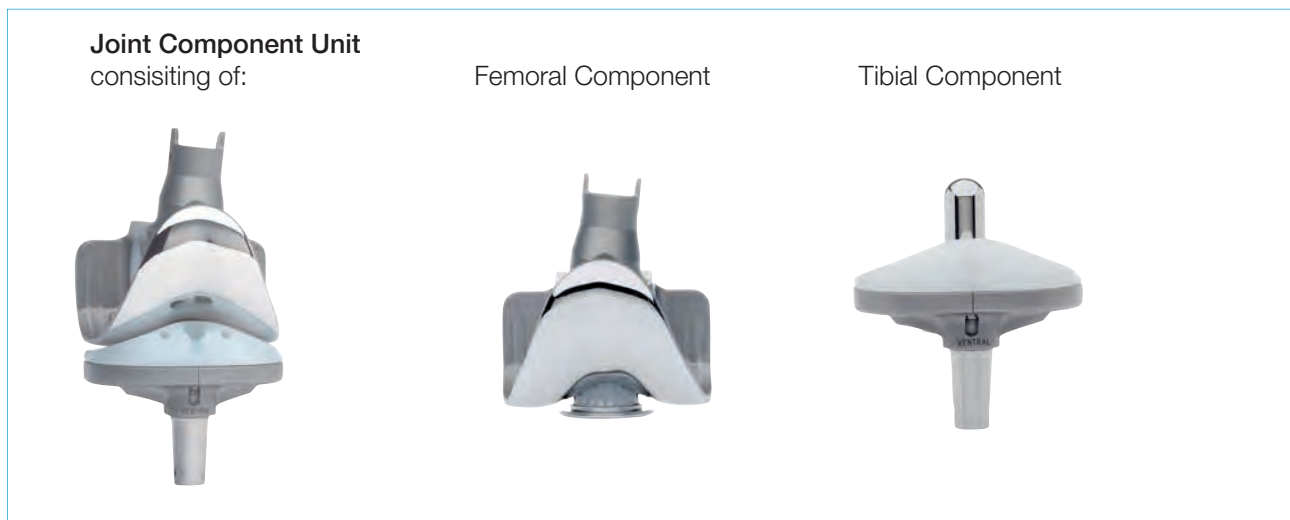

Endo-Model Modular Joint Component with female taper

Centralizers

Centralizers, for modular stems, height 15 mm

MAT UHMWPE

REF	Item no.	Ø
Set	consisting of:	
15-2975/01	15-2975/12	12 mm
	15-2975/14	14 mm
	15-2975/16	16 mm



LINK Patella Components

for Endo-Model SL Rotating and Non-Rotating Hinge Knee



Patella Components, 3-pegs

MAT UHMWPE

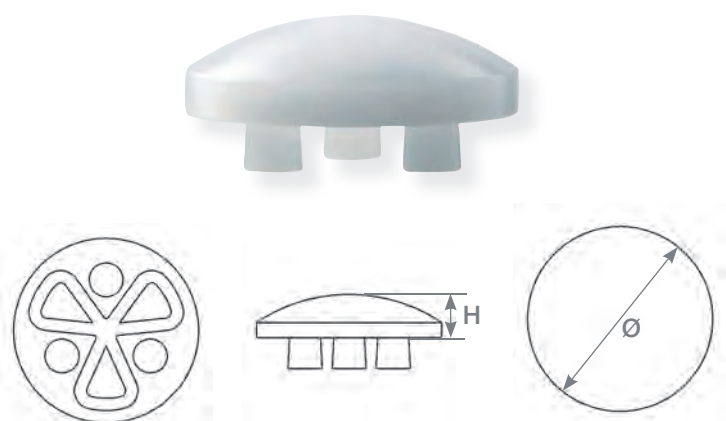
REF	Size	Ø	Height
318-401/25	1	25 mm	7 mm
318-401/28	2	28 mm	8 mm
318-401/31	3	31 mm	9 mm
318-401/34	4	34 mm	10 mm

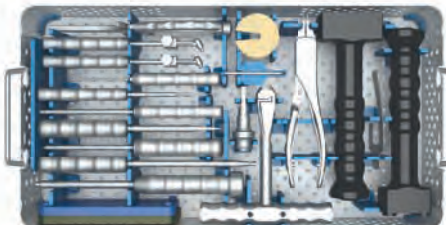

Overview Instrument Sets
for MEGASYSTEM-C Tumor and Revision System

<p>15-8710/02</p>	<p>Instrument Set</p>	<p>Tapered Reamers: 100 mm</p>
<p>consisting of: 15-8711/02</p>	<p>Instrument Tray, empty, 478 x 253 x76 mm</p> <p>Tray with detailed instruments, see page 74</p>	
<p>15-8720/02</p>	<p>Instrument Set</p>	<p>Tapered Reamers: 130 mm</p>
<p>consisting of: 15-8721/02</p>	<p>Instrument Tray, empty, 478 x 253 x76 mm</p> <p>Tray with detailed instruments, see page 75</p>	
<p>15-8730/02</p>	<p>Instrument Set</p>	<p>Tapered Reamers: 160 mm</p>
<p>consisting of: 15-8731/02</p>	<p>Instrument Tray, empty, 478 x 253 x76 mm</p> <p>Tray with detailed instruments, see page 76</p>	
<p>15-8740/02</p>	<p>Instrument Set</p>	<p>General Instruments I</p>
<p>consisting of: 15-8741/02</p>	<p>Instrument Tray, empty, 478 x 253 x76 mm</p> <p>Tray with detailed instruments, see page 77</p>	

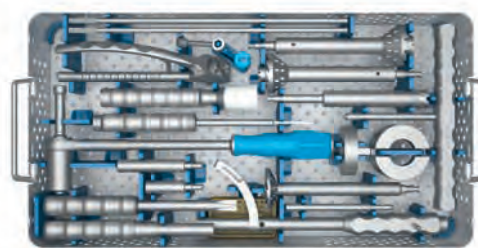
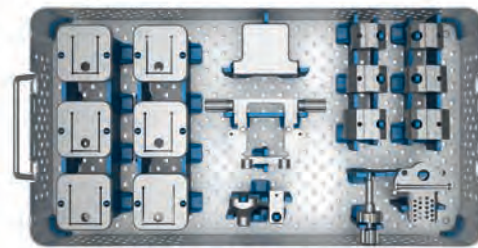
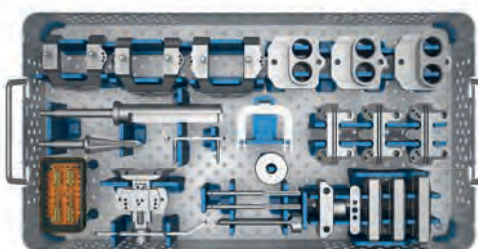
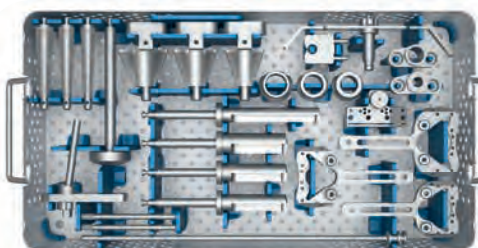
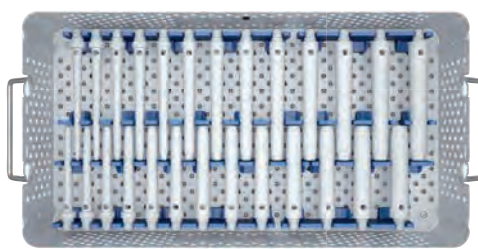
15-8750/02	Instrument Set	General Instruments II
consisting of: 15-8751/02	Instrument Tray , empty, 478 x 253 x76 mm Tray with detailed instruments, see page 78	
15-8760/02	Instrument Set	Femur I
consisting of: 15-8761/02	Instrument Tray , empty, 478 x 253 x76 mm Tray with detailed instruments, see page 79	
15-8770/02	Instrument Set	Femur II
consisting of: 15-8771/02	Instrument Tray , empty, 478 x 253 x 76 mm Tray with detailed instruments, see page 80	
15-8780/02	Instrument Set	Tibia
consisting of: 15-8781/02	Instrument Tray , empty, 478 x 253 x 76 mm Tray with detailed instruments, see page 81	
15-8790/02	Instrument Set (1)	Trial Stems Femur: 100 und 130 mm
consisting of: 15-8791/02	Instrument Tray , empty, lower 478 x 253 x 106 mm Tray with detailed instruments, see page 82	

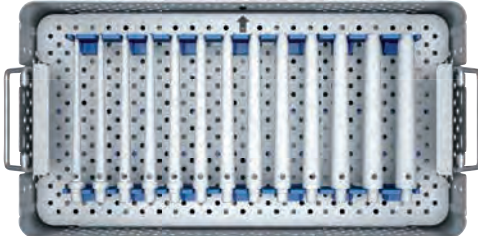
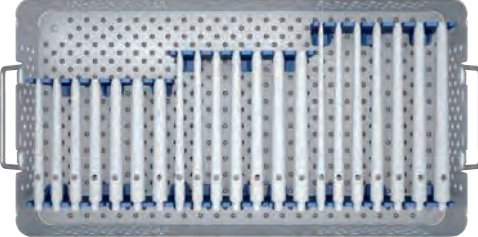
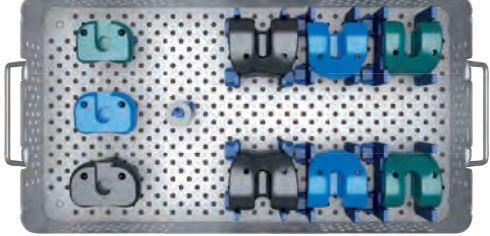
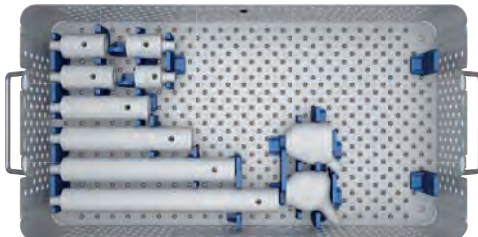
<p>15-8790/02</p>	<p>Instrument Set (2)</p>	<p>Trial Stems Femur: 160 mm</p>
<p>consisting of: 15-8791/02</p>	<p>Instrument Tray, empty, upper 478 x 253 x 106 mm</p> <p>Tray with detailed instruments, see page 83</p>	
<p>15-8810/02</p>	<p>Instrument Set</p>	<p>Trial Stems Tibia: 100, 130 und 160 mm</p>
<p>consisting of: 15-8811/02</p>	<p>Instrument Tray, empty, 478 x 253 x 76 mm</p> <p>Tray with detailed instruments, see page 84</p>	
<p>15-8820/03</p>	<p>Instrument Set</p>	<p>Trial Prostheses: Femur/Tibia, intracondylar</p>
<p>consisting of: 15-8821/03</p>	<p>Instrument Tray, empty, 478 x 253 x 76 mm</p> <p>Tray with detailed instruments, see page 85</p>	
<p>15-8840/03</p>	<p>Instrument Set</p>	<p>Trial Prostheses: Distal Femur and Proximal Tibial Replacement</p>
<p>consisting of: 15-8841/02</p>	<p>Instrument Tray, empty, 478 x 253 x 76 mm</p> <p>Tray with detailed instruments, see page 86</p>	
<p>15-8830/02</p>	<p>Instrument Set (1)</p>	<p>Trial Prostheses: Total Femur Replacement</p>
<p>consisting of: 15-8831/02</p>	<p>Instrument Tray, empty, lower 478 x 253 x 106 mm</p> <p>Tray with detailed instruments, see page 87</p>	

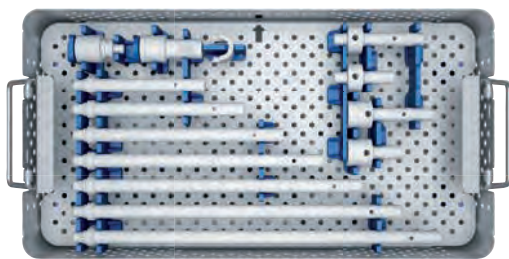
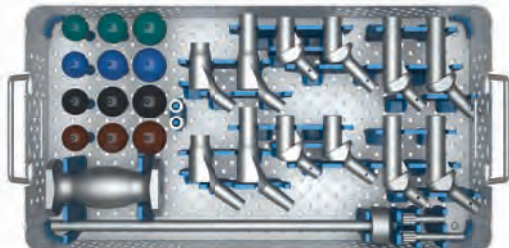
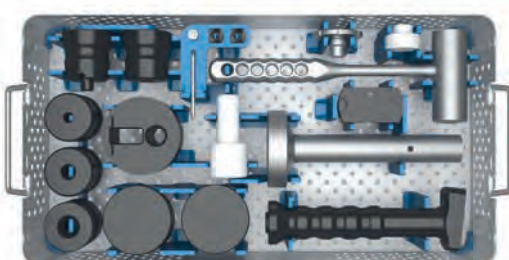
<p>15-8830/02</p>	<p>Instrument Set (2)</p>	<p>Trial Prostheses: Total Femur Replacement</p>
<p>consisting of: 15-8831/02</p>	<p>Instrument Tray, empty, upper 478 x 253 x 106 mm</p> <p>Tray with detailed instruments, see page 88</p>	
<p>134-020/00</p>	<p>Instrument Set</p>	<p>MP Trial Implants</p>
<p>consisting of: 134-021/00</p>	<p>Instrument Tray, empty, 478 x 253 x 76 mm</p> <p>Tray with detailed instruments, see page 89</p>	
<p>16-0100/02</p>	<p>Instrument Set</p>	<p>Assembly</p>
<p>consisting of: 16-0100/03</p>	<p>Instrument Tray, empty, 478 x 253 x 76 mm</p> <p>Tray with detailed instruments, see page 90</p>	

15-8710/02 Instrument Set – Tapered Reamers: 100 mm



1	15-8711/02	Instrument Tray , empty, 478 x 253 x 76 mm	
		Tapered Reamers: for prosthesis stems 100 mm, conical, with fitting B: Hudson	
2	16-5100/12	for: stem-Ø 12 mm	stem length 100 mm
3	16-5100/13	for: stem-Ø 13 mm	stem length 100 mm
4	16-5100/14	for: stem-Ø 14 mm	stem length 100 mm
5	16-5100/15	for: stem-Ø 15 mm	stem length 100 mm
6	16-5100/16	for: stem-Ø 16 mm	stem length 100 mm
7	16-5100/17	for: stem-Ø 17 mm	stem length 100 mm
8	16-5100/18	for: stem-Ø 18 mm	stem length 100 mm
9	16-5100/19	for: stem-Ø 19 mm	stem length 100 mm
10	16-5100/20	for: stem-Ø 20 mm	stem length 100 mm
11	16-5100/21	for: stem-Ø 21 mm	stem length 100 mm
12	16-5100/22	for: stem-Ø 22 mm	stem length 100 mm
13	16-5100/23	for: stem-Ø 23 mm	stem length 100 mm
14	16-5100/24	for: stem-Ø 24 mm	stem length 100 mm

15-8720/02 Instrument Set – Tapered Reamers: 130 mm



1	15-8721/02	Instrument Tray , empty, 478 x 253 x 76 mm	
		Tapered Reamers: for prosthesis stems 130 mm, conical, with fitting B: Hudson	
2	16-5130/12	for: stem-Ø 12 mm	stem length 130 mm
3	16-5130/13	for: stem-Ø 13 mm	stem length 130 mm
4	16-5130/14	for: stem-Ø 14 mm	stem length 130 mm
5	16-5130/15	for: stem-Ø 15 mm	stem length 130 mm
6	16-5130/16	for: stem-Ø 16 mm	stem length 130 mm
7	16-5130/17	for: stem-Ø 17 mm	stem length 130 mm
8	16-5130/18	for: stem-Ø 18 mm	stem length 130 mm
9	16-5130/19	for: stem-Ø 19 mm	stem length 130 mm
10	16-5130/20	for: stem-Ø 20 mm	stem length 130 mm
11	16-5130/21	for: stem-Ø 21 mm	stem length 130 mm
12	16-5130/22	for: stem-Ø 22 mm	stem length 130 mm
13	16-5130/23	for: stem-Ø 23 mm	stem length 130 mm
14	16-5130/24	for: stem-Ø 24 mm	stem length 130 mm

15-8730/02 Instrument Set – Tapered Reamers: 160 mm



1	15-8731/02	Instrument Tray , empty, 478 x 253 x 76 mm	
		Tapered Reamers: for prosthesis stems 160 mm, conical, with fitting B: Hudson	
2	16-5160/12	for: stem-Ø 12 mm	stem length 160 mm
3	16-5160/13	for: stem-Ø 13 mm	stem length 160 mm
4	16-5160/14	for: stem-Ø 14 mm	stem length 160 mm
5	16-5160/15	for: stem-Ø 15 mm	stem length 160 mm
6	16-5160/16	for: stem-Ø 16 mm	stem length 160 mm
7	16-5160/17	for: stem-Ø 17 mm	stem length 160 mm
8	16-5160/18	for: stem-Ø 18 mm	stem length 160 mm
9	16-5160/19	for: stem-Ø 19 mm	stem length 160 mm
10	16-5160/20	for: stem-Ø 20 mm	stem length 160 mm
11	16-5160/21	for: stem-Ø 21 mm	stem length 160 mm
12	16-5160/22	for: stem-Ø 22 mm	stem length 160 mm
13	16-5160/23	for: stem-Ø 23 mm	stem length 160 mm
14	16-5160/24	for: stem-Ø 24 mm	stem length 160 mm

15-8740/02 Instrument Set – General Instruments I

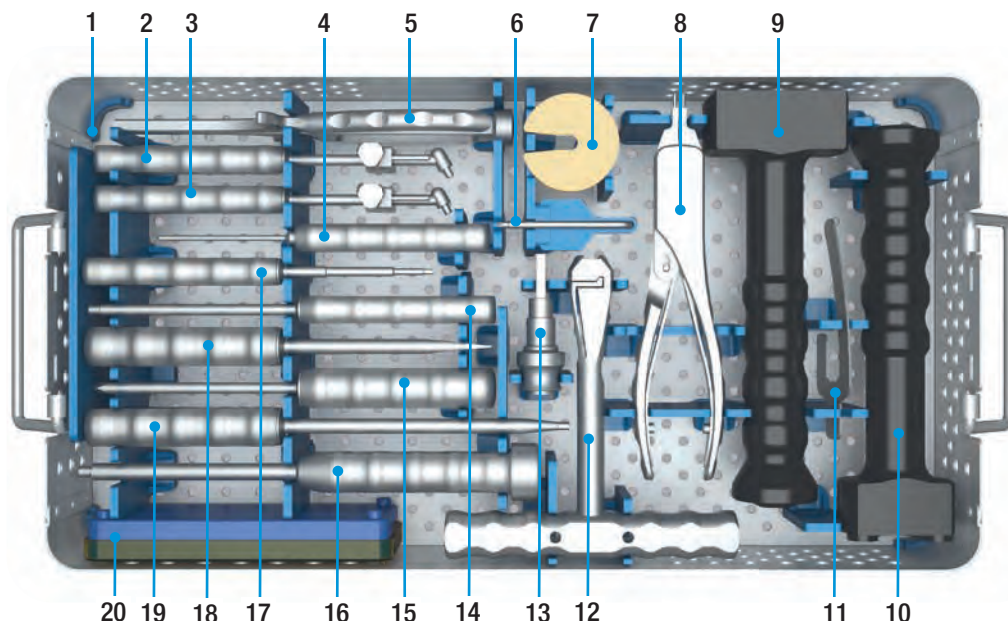

1	15-8741/02	Instrument Tray, empty, 478 x 253 x 76 mm
2	15-8035/02	Insertion Instrument for PE plateaus Endo-Model S, M and L
3	15-8035/03	Insertion Instrument for PE plateaus Endo-Model XS and Endo-Model SL
4	15-2546*	Hex Screwdriver, with torque limiting, wrench size 2.0 mm, 175 mm (for coupling mechanism V02)
5	317-586	Extraction Forceps for fixation pins, 210 mm
6	16-0116/01	Hex Screwdriver, wrench size 2.5 mm
7	16-3203/00	Impaction Plate for tapered reamers
8	16-0020/01*	Connecting/Disconnecting Forceps, 175 mm
9	317-646/01	Grooved Driver for femoral components, 210 mm
10	16-0018/02	Grooved Driver for tibial components SL
11	317-607/50	Cutting Template
12	15-6053/00	T-Handle, with Hudson fitting
13	16-3283/01	Adapter with fitting: Hudson female/Jacobs male Adapter fitting optional (not included in instrument set):
	16-3284/00	Hudson female/AO male
	16-3285/00	Hudson female/Harris male
14	16-0017/01	Separate Rod M5, 220 mm
15	317-658/01	Bone Awl, with trocar point, 215 mm
16	15-8516/45	Driver Extractor, for modular stems, 365 mm
17	10-5373/01	Hex Screwdriver, wrench size 2.5 mm, 180 mm
18	322-145/01	Screwdriver, blade width 8 mm, 210 mm
19	64-8008/02	Hex Screwdriver, wrench size 3.5 mm, 250 mm
	317-585/65	Wire Pins, Ø 3 mm, 65 mm (4 ea. included)
20	317-585/95	Wire Pins, Ø 3 mm, 95 mm (4 ea. included)
	319-602/30	Sterilizing Box

Optional:

* 64-1181/16 Hex Screwdriver, wrench size 2.0 mm, 175 mm (for coupling mechanism V01)

* 16-0020/02 Connecting/Disconnecting Forceps, slim, 175 mm

15-8750/02 Instrument Set – General Instruments II

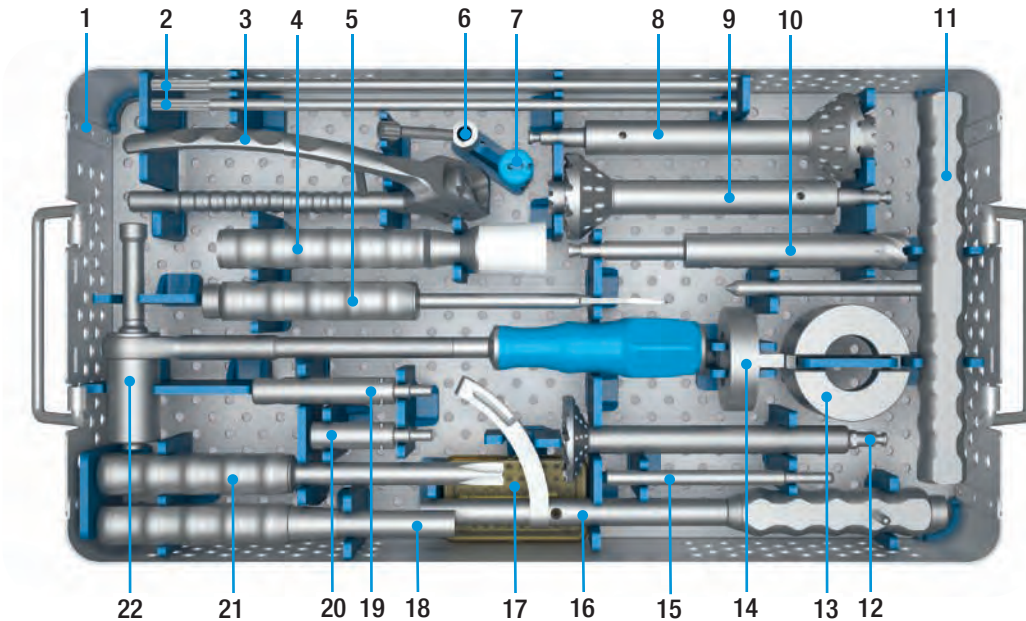

1	15-8751/02	Instrument Tray, empty, 478 x 253 x 76 mm
2	16-3235/00	Guide Rod for saw guide for notching (2 ea. included)
3	134-141/00	Insertion Forceps for MP neck segments
4	130-600	Driver for prosthesis heads
5	15-8516/41	Separator with metal handle, 235 mm
6	134-202/00	Caliper
7	131-830/04	Taper Cap
8	16-3204/24	Step Reamer, Ø 24 mm, with Hudson fitting
9	16-3204/18	Step Reamer, Ø 18 mm, with Hudson fitting
10	134-200/00	Hollow Reamer, with Hudson fitting
11	15-8506/52	Distraction Instrument with metal handle
12	16-3205/30	Reamer, Ø 46 mm, with Hudson fitting, 85 mm
13	16-3237/00	Saw Guide for notching
14	16-3236/00	Adapter Ring for saw guide for notching
15	134-201/00	Guide Rod
16	131-379/00	Inserter Positioner for neck segments standard and XXL
17	319-601/30	Sterilizing Box incl. screws, for insertion instrument 131-379/00
18	131-385/01	Screwdriver, hex 8 mm, 185 mm
19	134-204/35	Reaming Guide for neck segment standard
20	134-204/65	Reaming Guide for neck segment short
21	16-3290/00	Cross Slot Screwdriver with metal handle, 210 mm
22	134-140/00	Torque Wrench, hex 8 mm, 380 mm

15-8760/02 Instrument Set – Femur I

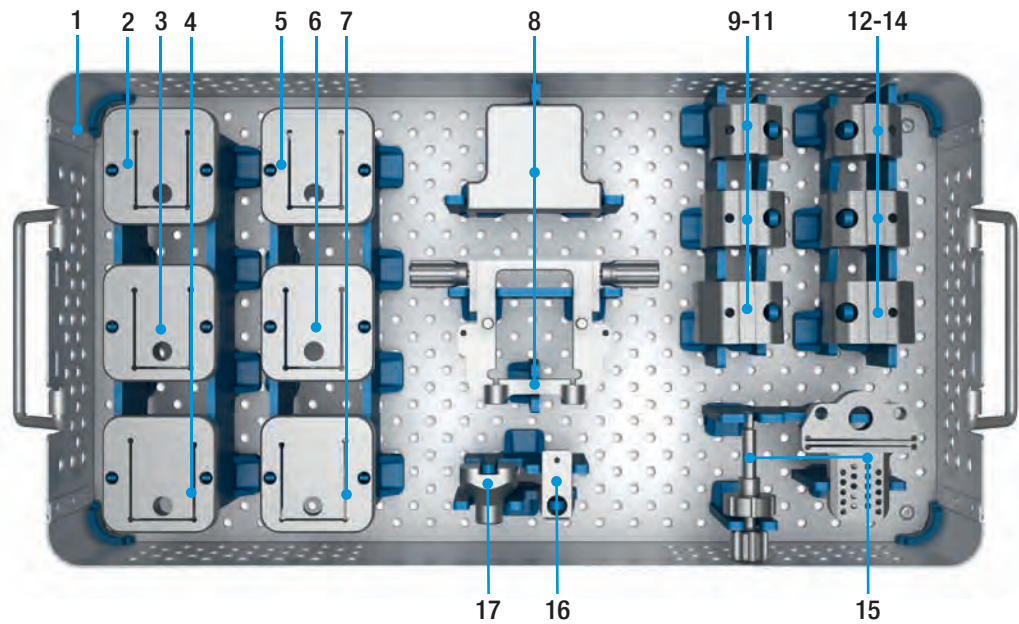

1	15-8761/02	Instrument Tray , empty, 478 x 253 x 76 mm
Saw Attachments for femoral components SL		
2	16-3221/01	small S right
3	16-3223/01	medium M right
4	16-3225/01	large L right
5	16-3221/02	small S left
6	16-3223/02	medium M left
7	16-3225/02	large L left
8	16-3278/00	Revision Alignment Gauge , distal, for femoral components SL (2 parts)
Femoral Trial Box for femoral components SL		
9	16-3261/01	small S right
10	16-3263/01	medium M right
11	16-3265/01	large L right
12	16-3261/02	small S left
13	16-3263/02	medium M left
14	16-3265/02	large L left
15	16-3277/00	Revision Cutting Block , distal, for femoral components SL (2 parts)
16	16-3282/00	Alignment Instrument for femoral trial box
17	16-3271/00	Adapter for femoral trial box

15-8770/02 Instrument Set – Femur II

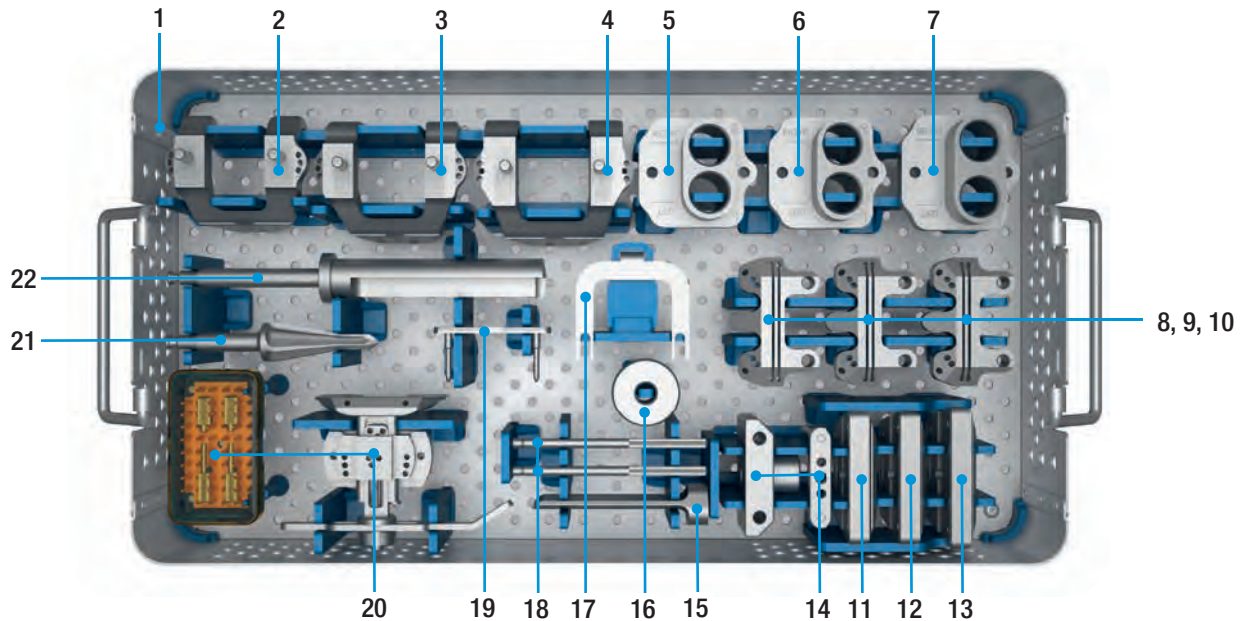

1	15-8771/02	Instrument Tray , empty, 478 x 253 x 76 mm	
Condyles Caps Femur			
2	16-3241/02	size 2	right/left
3	16-3241/03	size 3	right/left
4	16-3241/04	size 4	right/left
Drill Caps Femur, Ø 20 mm			
5	16-3213/02	size 2	right/left
6	16-3213/03	size 3	right/left
7	16-3213/04	size 4	right/left
Femur Cutting Blocks for distal cut			
8	16-3228/02	size 2	
9	16-3228/03	size 3	
10	16-3228/04	size 4	
Femur Cutting Blocks for chamfer cuts			
11	16-3250/02	size 2	
12	16-3250/03	size 3	
13	16-3250/04	size 4	
14	16-3275/00	Alignment Instrument for valgus angulation (2 parts)	
15	317-802/32	Chisel for patella glide, 80 mm	
16	16-3281/00	Center Sleeve for drill cap femur	
17	16-3279/00	Holding Clamp	
18	317-802/58	Alignment Rod for epicondyles, 100 mm (2 ea. included)	
19	317-802/36	Dove Tail Adapter , neutral, for femoral cutting blocks	
20	16-3276/00	Alignment Instrument for determination of external rotation (5 parts)	
	319-601/30	Sterilizing Box incl. screws, for alignment instrument 16-3276/00	
21	15-6037/00	Drill , conical, to open femoral and tibial cavity, with Hudson fitting	
22	16-3206/20	Drill , with stop, with Hudson fitting, Ø 20 mm	

15-8780/02 Instrument Set – Tibia

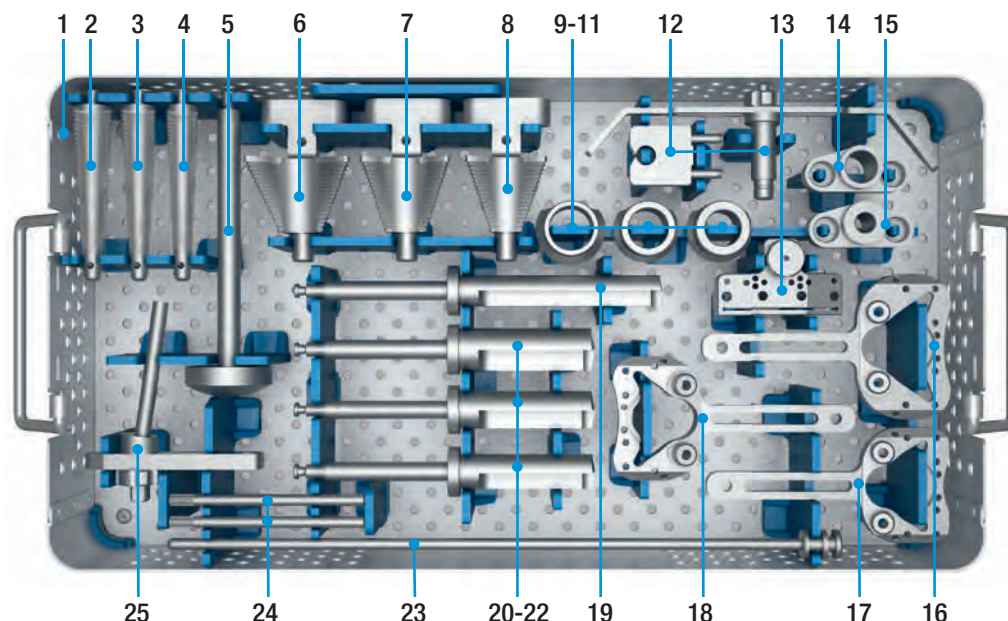

1	15-8781/02	Instrument Tray , empty, 478 x 253 x 76 mm
		Stem Compressors for tibial components SL
2	16-3201/04	large L
3	16-3201/03	medium M
4	16-3201/02	small S
5	16-3197/00	Handle for tibial compressor/femoral trial box
		Compressors for tibial components SL
6	16-3199/14	large L
7	16-3199/13	medium M
8	16-3199/12	small S
		Drill Guides for drill templates
9	16-3270/22	large L
10	16-3270/20	medium M
11	16-3270/18	small S
12	317-802/52	Stylus for tibial saw guide, adjustable (2 parts)
13	16-3241/00	Tibial Saw Guide for tibial components SL
14	16-3267/00	Drill Guide , tibia, for ventral cut, Ø 16 mm
15	16-3266/00	Alignment Gauge , tibia, for drill templates
		Drill Templates for tibial components SL
16	16-3198/14	large L
17	16-3198/12	small S
18	16-3198/13	medium M
19	16-3207/16	Drill with stop , for tibial components SL, ventral side, Ø 16 mm
		Drill with stop , for tibial components SL
20	16-3208/22	large L Ø 22 mm
21	16-3208/20	medium M Ø 20 mm
22	16-3208/18	klein S Ø 18 mm
23	16-3242/00	Alignment Rod Tibia
24	16-3211/00	Guide Rod , tibia, for drill template (2 ea. included)
25	16-3212/08	Connector , size 8°, for tapered reamer/tibial saw guide

15-8790/02 Instrument Set (1) – Femoral Trial Stems: 100 mm und 130 mm

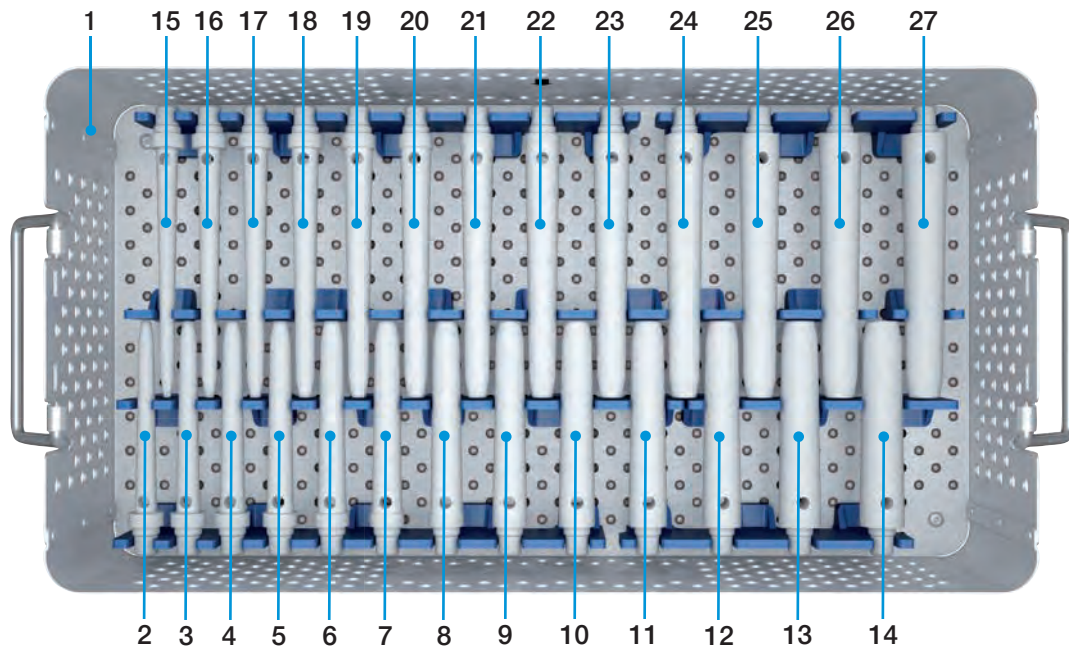

1	15-8791/02	Instrument Tray, below, empty, 478 x 253 x 106 mm	
		Trial Stems for prosthesis stems 100 mm, conical	
2	16-3101/12	for: stem-Ø 12 mm	stem length 100 mm
3	16-3101/13	for: stem-Ø 13 mm	stem length 100 mm
4	16-3101/14*	for: stem-Ø 14 mm	stem length 100 mm
5	16-3101/15	for: stem-Ø 15 mm	stem length 100 mm
6	16-3101/16*	for: stem-Ø 16 mm	stem length 100 mm
7	16-3101/17	for: stem-Ø 17 mm	stem length 100 mm
8	16-3101/18*	for: stem-Ø 18 mm	stem length 100 mm
9	16-3101/19	for: stem-Ø 19 mm	stem length 100 mm
10	16-3101/20	for: stem-Ø 20 mm	stem length 100 mm
11	16-3101/21	for: stem-Ø 21 mm	stem length 100 mm
12	16-3101/22	for: stem-Ø 22 mm	stem length 100 mm
13	16-3101/23	for: stem-Ø 23 mm	stem length 100 mm
14	16-3101/24	for: stem-Ø 24 mm	stem length 100 mm
		Trial Stems for prosthesis stems 130 mm, conical	
15	16-3131/12	for: stem-Ø 12 mm	stem length 130 mm
16	16-3131/13	for: stem-Ø 13 mm	stem length 130 mm
17	16-3131/14*	for: stem-Ø 14 mm	stem length 130 mm
18	16-3131/15	for: stem-Ø 15 mm	stem length 130 mm
19	16-3131/16*	for: stem-Ø 16 mm	stem length 130 mm
20	16-3131/17	for: stem-Ø 17 mm	stem length 130 mm
21	16-3131/18*	for: stem-Ø 18 mm	stem length 130 mm
22	16-3131/19	for: stem-Ø 19 mm	stem length 130 mm
23	16-3131/20	for: stem-Ø 20 mm	stem length 130 mm
24	16-3131/21	for: stem-Ø 21 mm	stem length 130 mm
25	16-3131/22	for: stem-Ø 22 mm	stem length 130 mm
26	16-3131/23	for: stem-Ø 23 mm	stem length 130 mm
27	16-3131/24	for: stem-Ø 24 mm	stem length 130 mm

* also for cemented stems 12, 14 und 16 mm

15-8790/02 Instrument Set (2) – Femoral Trial Stems: 160 mm

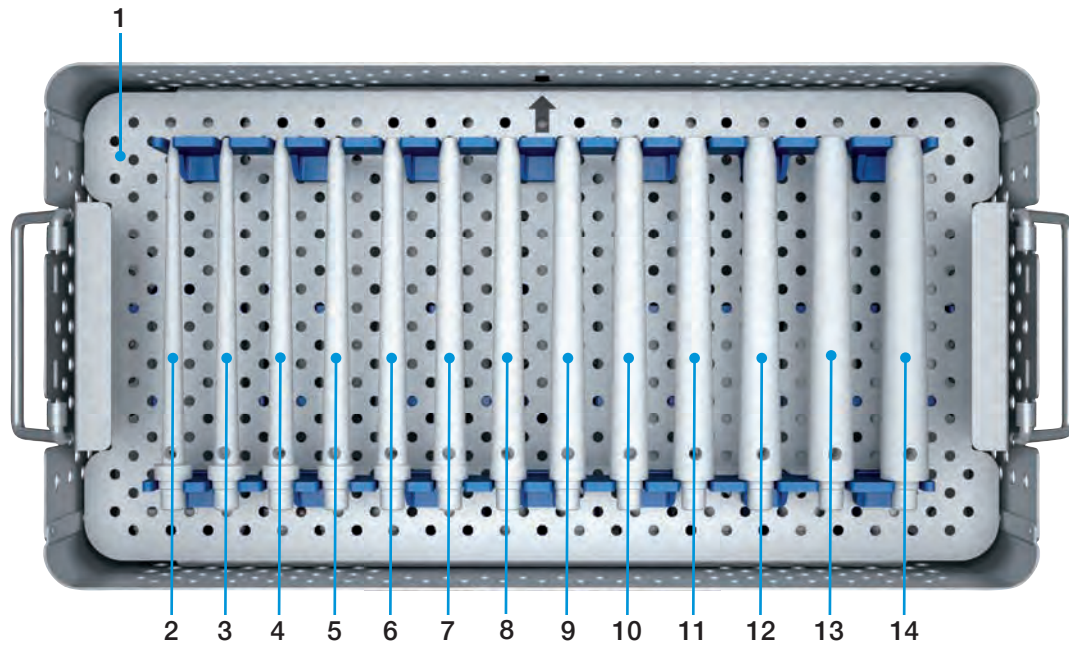

1	15-8791/02	Instrument Tray, above, empty, 478 x 253 x 106 mm	
Trial Stems for prosthesis stems 160 mm, conical			
2	16-3161/12	for: stem-Ø 12 mm	stem length 160 mm
3	16-3161/13	for: stem-Ø 13 mm	stem length 160 mm
4	16-3161/14*	for: stem-Ø 14 mm	stem length 160 mm
5	16-3161/15	for: stem-Ø 15 mm	stem length 160 mm
6	16-3161/16*	for: stem-Ø 16 mm	stem length 160 mm
7	16-3161/17	for: stem-Ø 17 mm	stem length 160 mm
8	16-3161/18*	for: stem-Ø 18 mm	stem length 160 mm
9	16-3161/19	for: stem-Ø 19 mm	stem length 160 mm
10	16-3161/20	for: stem-Ø 20 mm	stem length 160 mm
11	16-3161/21	for: stem-Ø 21 mm	stem length 160 mm
12	16-3161/22	for: stem-Ø 22 mm	stem length 160 mm
13	16-3161/23	for: stem-Ø 23 mm	stem length 160 mm
14	16-3161/24	for: stem-Ø 24 mm	stem length 160 mm

* also for cemented stems 12, 14 und 16 mm

15-8810/02 Instrument Set – Tibial Trial Stems: 100, 130 und 160 mm

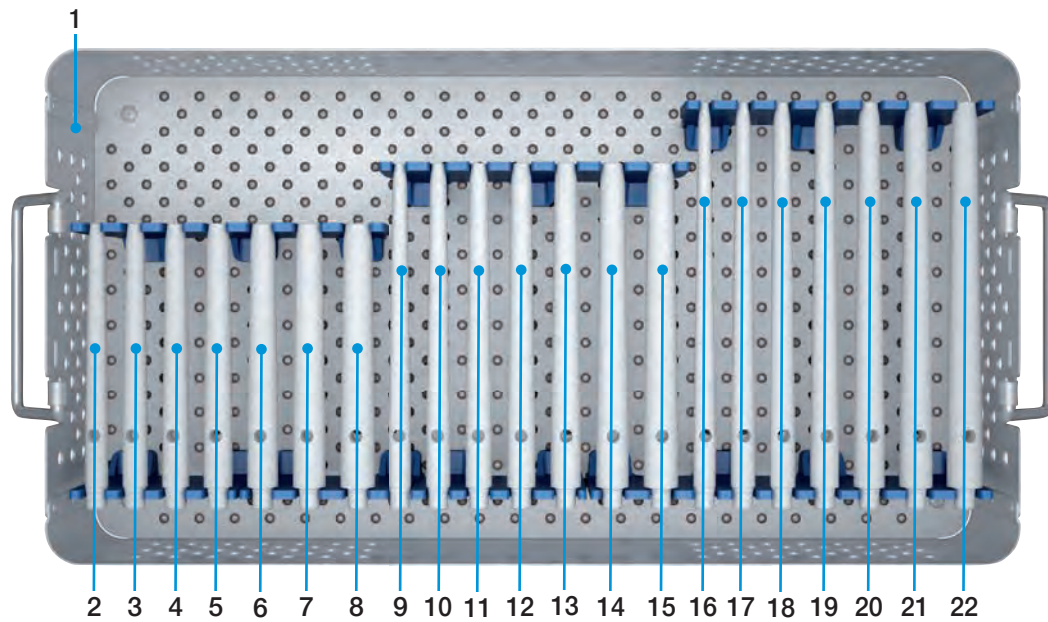

1	15-8811/02	Instrument Tray , empty, 478 x 253 x 76 mm	
Trial Stems for modular tibia: 100 mm, conical			
2	16-4101/12	for: stem-Ø 12 mm	for modular tibia 100 mm
3	16-4101/13	for: stem-Ø 13 mm	for modular tibia 100 mm
4	16-4101/14*	for: stem-Ø 14 mm	for modular tibia 100 mm
5	16-4101/15	for: stem-Ø 15 mm	for modular tibia 100 mm
6	16-4101/16*	for: stem-Ø 16 mm	for modular tibia 100 mm
7	16-4101/17	for: stem-Ø 17 mm	for modular tibia 100 mm
8	16-4101/18*	for: stem-Ø 18 mm	for modular tibia 100 mm
Trial Stems for modular tibia: 130 mm, conical			
9	16-4131/12	for: stem-Ø 12 mm	for modular tibia 130 mm
10	16-4131/13	for: stem-Ø 13 mm	for modular tibia 130 mm
11	16-4131/14*	for: stem-Ø 14 mm	for modular tibia 130 mm
12	16-4131/15	for: stem-Ø 15 mm	for modular tibia 130 mm
13	16-4131/16*	for: stem-Ø 16 mm	for modular tibia 130 mm
14	16-4131/17	for: stem-Ø 17 mm	for modular tibia 130 mm
15	16-4131/18*	for: stem-Ø 18 mm	for modular tibia 130 mm
Trial Stems for modular tibia: 160 mm, conical			
16	16-4161/12	for: stem-Ø 12 mm	for modular tibia 160 mm
17	16-4161/13	for: stem-Ø 13 mm	for modular tibia 160 mm
18	16-4161/14*	for: stem-Ø 14 mm	for modular tibia 160 mm
19	16-4161/15	for: stem-Ø 15 mm	for modular tibia 160 mm
20	16-4161/16*	for: stem-Ø 16 mm	for modular tibia 160 mm
21	16-4161/17	for: stem-Ø 17 mm	for modular tibia 160 mm
22	16-4161/18*	for: stem-Ø 18 mm	for modular tibia 160 mm

* also for cemented stems 12, 14 und 16 mm

15-8820/03 Instrument Set – Trial Prostheses: Femur/Tibia, intracondylar

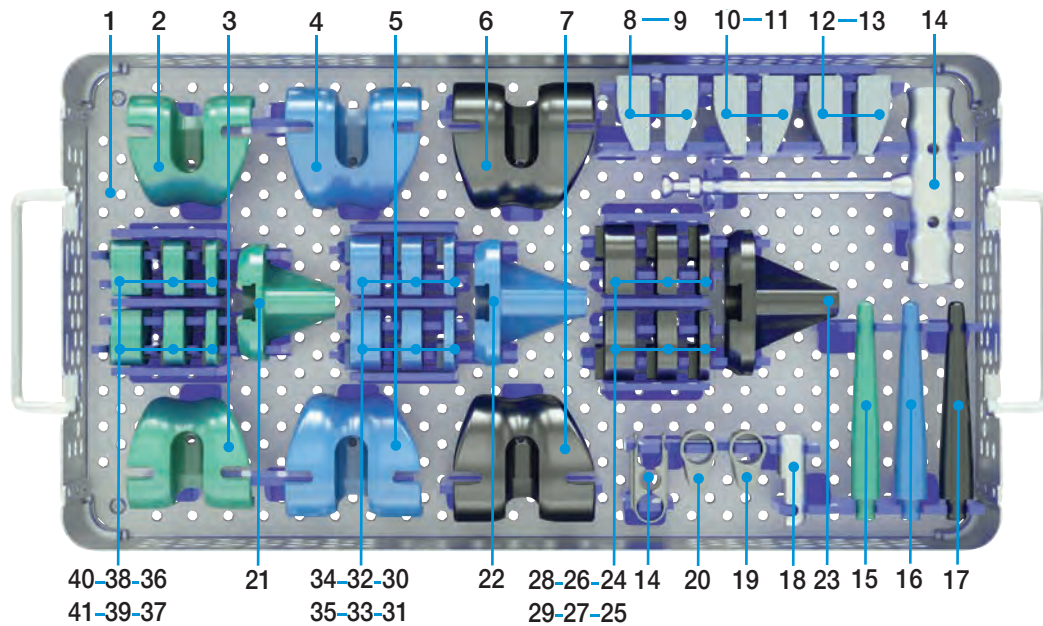

1	15-8821/03	Instrument Tray , empty, 478 x 253 x 76 mm			
Trial Prostheses Femur, intracondylar					
2	16-3181/12	left	small S		green
3	16-3181/11	right	small S		green
4	16-3183/12	left	medium M		blue
5	16-3183/11	right	medium M		blue
6	16-3185/12	left	large L		black
7	16-3185/11	right	large L		black
Femoral Trial Segments					
8	16-4368/12	left	S/M/L	15 mm height	
9	16-4368/11	right	S/M/L	15 mm height	
10	16-4368/02	left	S/M/L	25 mm height	
11	16-4368/01	right	S/M/L	25 mm height	
12	16-4368/22	left	S/M/L	full	
13	16-4368/21	right	S/M/L	full	
14	15-6061/00	Extraction Instrument for trial prostheses (2 parts)			
15	16-3170/12	Tibial Trial Stems , small S			green
16	16-3170/13	Tibial Trial Stems , medium M			blue
17	16-3170/14	Tibial Trial Stems , large L			black
18	16-4367/20	Trial Axis for mobile and hinged versions			
19	16-4367/00	Trial Connection Component for hinge knee			
20	16-4367/10	Trial Connection Component for rotational knee			
21	16-3175/12	Tibial Trial Prostheses , intracondylar, small S			green
22	16-3175/13	Tibial Trial Prostheses , intracondylar, medium M			blue
23	16-3175/14	Tibial Trial Prostheses , intracondylar, large L			black
Tibial Trial Spacers, intracondylar					
24	16-4361/03	right	large L	5 mm height	black
25	16-4362/03	left	large L	5 mm height	black
26	16-4363/03	right	large L	10 mm height	black
27	16-4364/03	left	large L	10 mm height	black
28	16-4365/03	right	large L	15 mm height	black
29	16-4366/03	left	large L	15 mm height	black
30	16-4361/02	right	medium M	5 mm height	blue
31	16-4362/02	left	medium M	5 mm height	blue
32	16-4363/02	right	medium M	10 mm height	blue
33	16-4364/02	left	medium M	10 mm height	blue
34	16-4365/02	right	medium M	15 mm height	blue
35	16-4366/02	left	medium M	15 mm height	blue
36	16-4361/01	right	small S	5 mm height	green
37	16-4362/01	left	small S	5 mm height	green
38	16-4363/01	right	small S	10 mm height	green
39	16-4364/01	left	small S	10 mm height	green
40	16-4365/01	right	small S	15 mm height	green
41	16-4366/01	left	small S	15 mm height	green

15-8840/03 Instrument Set – Trial Instruments: Distal Femur and Proximal Tibial Replacement

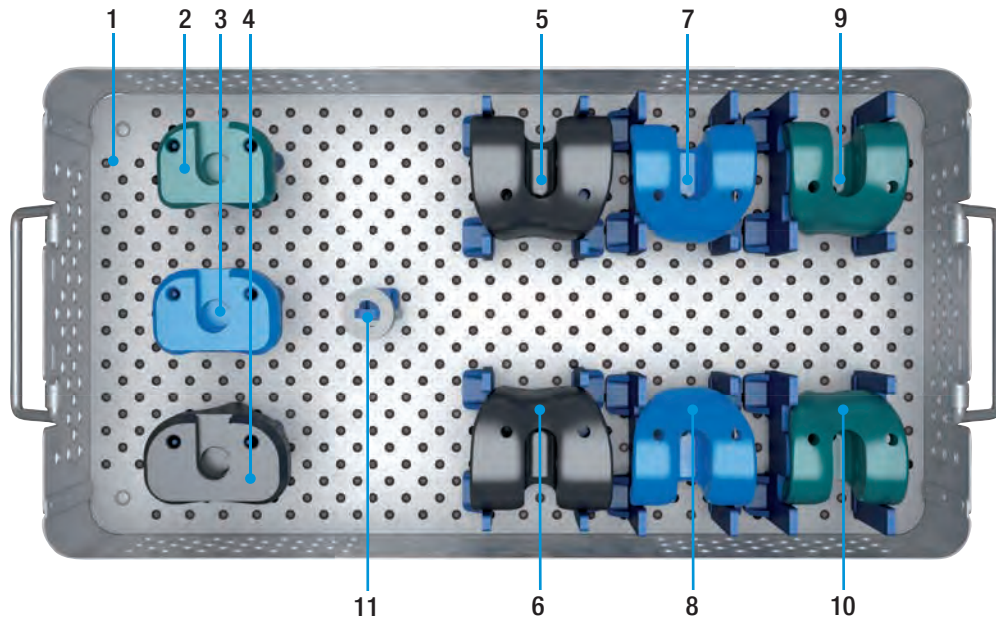

1	15-8841/02	Instrument Tray , empty, 478 x 253 x 76 mm			
		Trial Prostheses for proximal tibia replacement			
2	16-3180/12	small S	green		
3	16-3180/13	medium M	blue		
4	16-3180/14	large L	black		
		Trial Prostheses for distal femur replacement, slim, X-ray opaque			
5	16-3195/21	large L	right	black	
6	16-3195/22	large L	left	black	
7	16-3193/21	medium M	right	blue	
8	16-3193/22	medium M	left	blue	
9	16-3191/21	small S	right	green	
10	16-3191/22	small S	left	green	
11	15-6094/00	Trial Support Ring , Ø 28 mm, height 10 mm			

		Optional: X-ray opaque Trial Prostheses			
		Femoral Trial Prostheses , intracondylar, X-ray opaque			
	16-3181/21	small S	right	green	
	16-3181/22	small S	left	green	
	16-3183/21	medium M	right	blue	
	16-3183/22	medium M	left	blue	
	16-3185/21	large L	right	black	
	16-3185/22	large L	left	black	
		Tibial Trial Prostheses , intracondylar, X-ray opaque			
	16-3175/22	small S	green		
	16-3175/23	medium M	blue		
	16-3175/24	large L	black		
		Trial Prostheses for proximal tibia replacement, X-ray opaque			
	16-3180/22	small S	green		
	16-3180/23	medium M	blue		
	16-3180/24	large L	black		

15-8830/02 Instrument Set (1) – Trial Prostheses: Total Femur Replacement

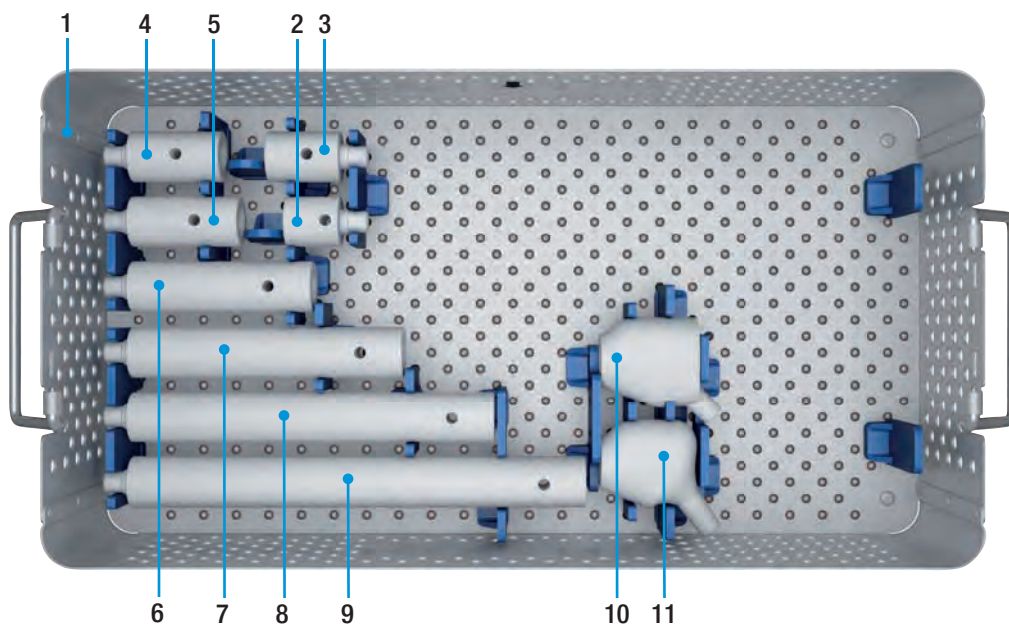

1	15-8831/02	Instrument Tray, below, empty, 478 x 253 x 106 mm
Trial Prostheses for stem segments		
2	16-3030/01	30 mm
3	16-3040/01	40 mm
4	16-3050/01	60 mm
5	16-3060/01	60 mm
6	16-3100/01	100 mm
7	16-3150/01	150 mm
8	16-3200/01	200 mm
9	16-3250/01	250 mm
Trial Neck Segments		
10	16-3213/35	135° CCD-Angle
11	16-3213/26	126° CCD-Angle

15-8830/02 Instrument Set (2) – Trial Prostheses: Total Femur Replacement

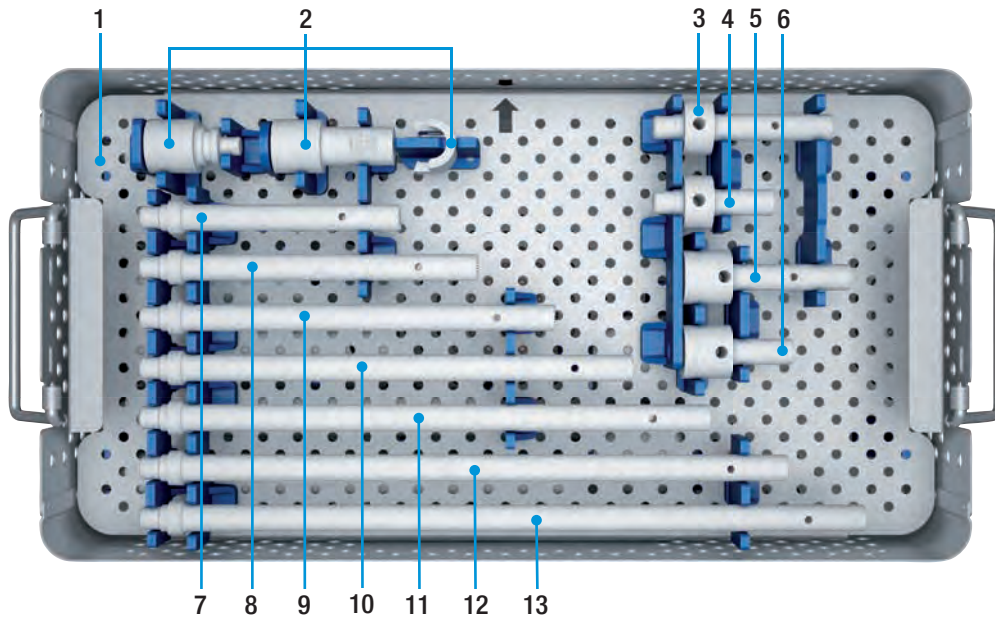

1	15-8831/02	Instrument Tray, above, empty, 478 x 253 x 106 mm
2	16-3204/01	Trial Prostheses for coupling for diaphyseal spacer (3 parts) Couplings
3	16-3212/26	for total femur replacement, long
4	16-3212/24	for total femur replacement, short
5	16-3212/30	for proximal femur replacment, long
6	16-3212/28	for proximal femur replacment, short
		Trial Prostheses for push-through stems
7	16-4120/01	120 mm
8	16-4160/01	160 mm
9	16-4200/01	200 mm
10	16-4240/01	240 mm
11	16-4280/01	280 mm
12	16-4320/01	320 mm
13	16-4360/01	360 mm

134-020/00 Instrument Set – MP Trial Prostheses

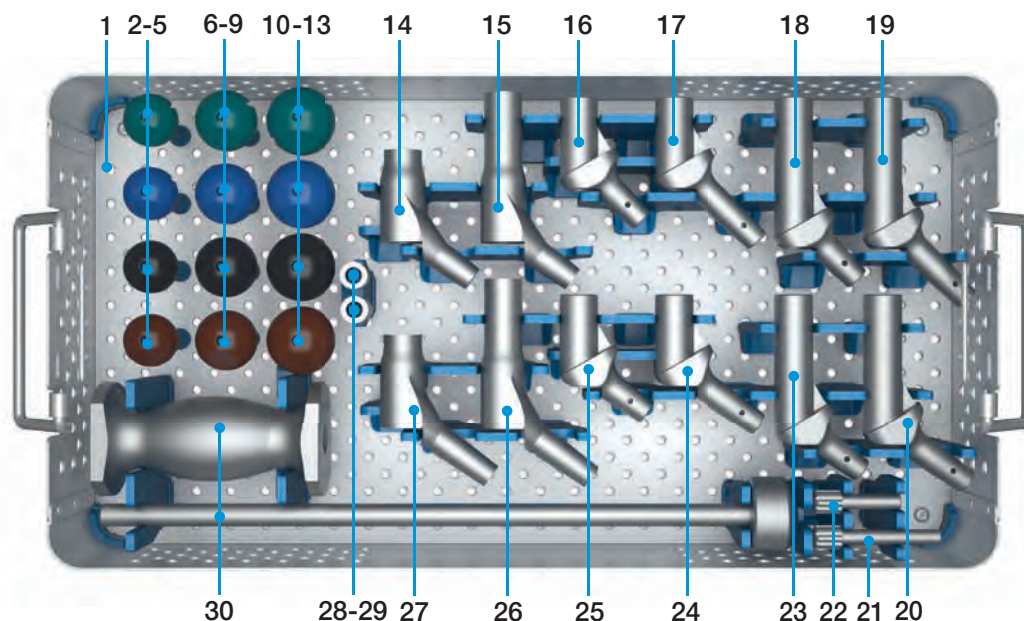

1	134-021/00	Instrument Tray, empty, 478 x 253 x 76 mm
		Trial Heads, Ø 28 mm
2	175-928/11	size S
3	175-928/12	size M
4	175-928/13	size L
5	175-928/14 *	size XL
		Trial Heads, Ø 32 mm
6	175-932/11	size S
7	175-932/12	size M
8	175-932/13	size L
9	175-932/14	size XL
		Trial Heads, Ø 36 mm
10	175-936/11	size S
11	175-936/12	size M
12	175-936/13	size L
13	175-936/14	size XL
14	99-0984/33	Trial Neck Segment, 35 mm, 126° with suture hole
15	99-0984/31	Trial Neck Segment, 65 mm, 126° with suture hole
16	131-395/35	Trial Neck Segment, 35 mm, 135°
17	131-393/35	Trial Neck Segment XXL, 35 mm, 135°
18	131-396/35	Trial Neck Segment, 65 mm, 135°
19	131-394/35	Trial Neck Segment XXL, 65 mm, 135°
20	131-394/26	Trial Neck Segment XXL, 65 mm, 126°
21	134-100/61	Trial Fixation Screw, long
22	134-100/41	Trial Fixation Screw, short
23	131-396/26	Trial Neck Segment, 65 mm, 126°
24	131-393/26	Trial Neck Segment XXL, 35 mm, 126°
25	131-395/26	Trial Neck Segment, 35 mm, 126°
26	99-0984/27	Trial Neck Segment, 65 mm, 126° with suture hole
27	99-0984/29	Trial Neck Segment, 35 mm, 126° with suture hole
28	131-398/10	Trial Proximal Spacer, 10 mm
29	131-398/20	Trial Proximal Spacer, 20 mm
30	317-661	Threaded Rod with Slap Hammer, 365 mm

* Optional: Trial Heads XL 175-928/15 and XXL 175-928/16 are available – corresponding to implants 198-828/04 and /05.

16-0100/02 Instrument Set – Assembling

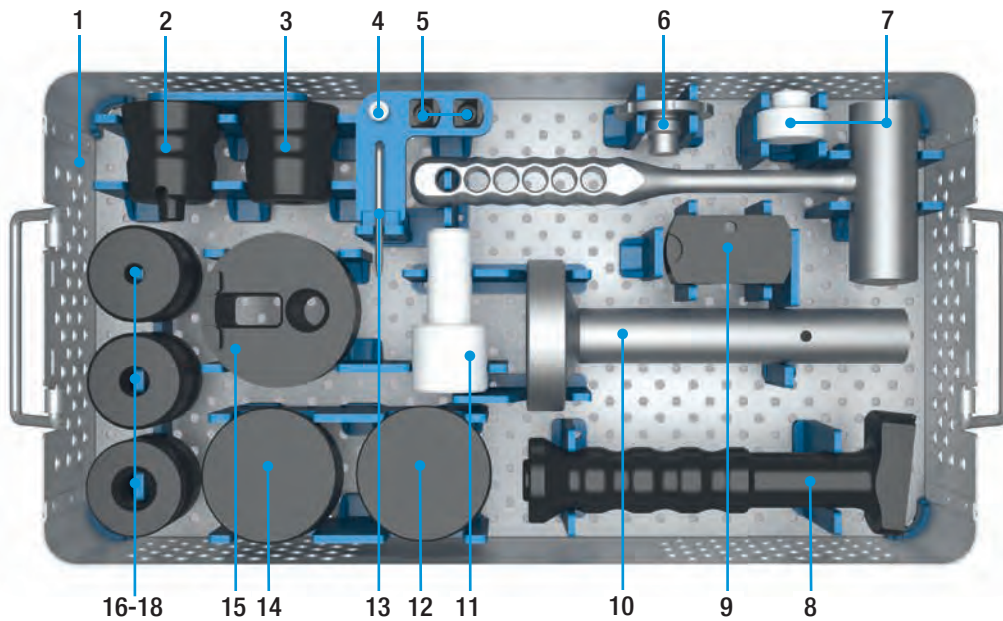

1	16-0100/03	Instrument Tray, empty, 478 x 253 x 76 mm
2	16-0111/02	Assembling Protector for male taper
3	16-0111/01	Assembling Protector for female taper
4	16-0114/04	Screw for assembling protectors femur
5	16-0114/02	Block, spare part for femur assembling protector 16-0114/01 (2 ea. included)
6	16-0113/01	Metal Core for assembling protector, for modular stem (size 1 – 3)
7	16-0115/01	Mallet, non-resilient, 800 g, complete
8	16-0114/01	Handle for femur assembling protector
9	16-0114/03	Plate, spare part for femur assembling protector 16-0114/01
10	16-0118/01	Assembling Table: upper part
11	16-0118/03	Assembling Table: silencer
12	16-0110/02	Tibia Assembling Plate for Endo-Model SL knee prostheses
13	16-0116/02	Hex Screwdriver, wrench size 5 mm, conical
14	16-0110/01	Femur Assembling Plate
15	16-0110/03	Tibia Assembling Plate for Endo-Model knee prostheses
16	16-0112/01	Assembling Protectors, size 1
17	16-0112/02	Assembling Protectors, size 2
18	16-0112/03	Assembling Protectors, size 3
	16-0118/02*	Assembling Table: lower part

* Not included in Instrument Set 16-0100/02

Assembling Instruments

for MEGASYSTEM-C Tumor and Revision System



16-0118/01

Assembling Table: Superior Component



16-0118/02

Assembling Table: Inferior Component
with fixed base plate



16-0118/03

Assembling Table: Silence



16-0110/01
Femur Assembling Plate



16-0110/02
Tibia Assembling Plate
 for Endo-Model SL Knee Prostheses

16-0110/03
Tibia Assembling Plate
 for Endo-Model Knee Prostheses



16-0111/01
Assembling Protector for female taper



16-0111/02
Assembling Protector for male taper



Assembling Protectors
16-0112/01 for modular stem, size 1
16-0112/02 for modular stem, size 2
16-0112/03 for modular stem, size 3



16-0113/01
Metal Core for assembling protector,
 for modular stem (size 1-3)



16-0114/01
Femur Assembling Protector,
 complete



16-0114/02
Block, for femur assembling protector
 (Spare part included in 16-0114/01)



16-0114/03
Plate, for femur assembling protector
 (Spare part included in 16-0114/01)



16-0115/01
Mallet, non-resilient proof, 800 g,
 complete

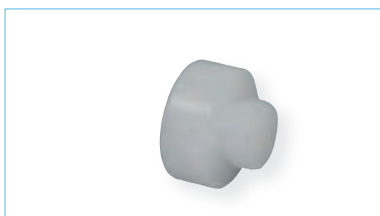

16-0115/02
Spare Mallet Head
 (Spare part included in 16-0115/01)



16-0116/02
Hex Screwdriver,
 SW 5 mm

Description of Use: Mounting the Assembling Table

The assembling table is mounted before the operation as illustrated below.

The superior component (16-0118/01) and the silencer (16-0118/03) are assembled in sterile condition. The inferior component (16-0118/02) with fixed base plate may be kept non-sterile.



The silencer is screwed onto the inferior component.



The superior component is attached.

In use of the assembling table, place foot on base plate to prevent the table from toppling over.

The table is dismantled in reverse order.

Description of Use: Connecting modular Stems to Modular Femoral and Tibial Components



The femur assembling plate (16-0110/01) is placed into the reception of the superior component of the assembling table (16-0118/01).



According to the chosen size of modular stem, the metal core (16-0113/01) is screwed into assembling protector modular stem, size 1-3 (16-0112/01-03).



Prosthesis stem and femoral joint component are connected by hand (the taper surfaces must be clean and dry) and, observing



the 6° valgus alignment of the femoral implant, placed on the assembling plate so that the prosthesis stem is vertical. If not, the implant assembly must be rotated 180°.

As shown in the picture, the components are struck with two powerful blows of the non-resilient mallet (16-0115/01) in order to firmly engage the taper connection (the second blow is a safety measure). The metal face of the mallet must only be used.



When using modular tibial implants, the tibial assembling plate (16-0110/02 or 16-0110/03) is first placed into the reception of the superior table component.



Proceed according to the assembly of modular femoral implant. Before using the locking screws, the taper connections must be connected firmly as described, using the assembling instruments.

Description of Use: Connecting Stem Elements



The assembling protector for female taper (16-0111/01) is placed into the reception of the assembling table superior component.



Attaching the selected stem element.



Attaching the stem element to be connected and the assembling protector for male taper (16-0111/02).



Assemble the elements with two blows of the non-resilient mallet, using the metal face of the mallet only.

Use and Mounting of the Femur Assembling Protector

Use

The femur assembling protector is always used if the surgical procedure does not permit assembly of implant components outside the operating field (e.g. connecting femoral joint components to push-through stems). The instrument compensates for the valgus geometry of the knee implant and permits the engagement of the tapers in axial alignment in the transverse and sagittal plane.

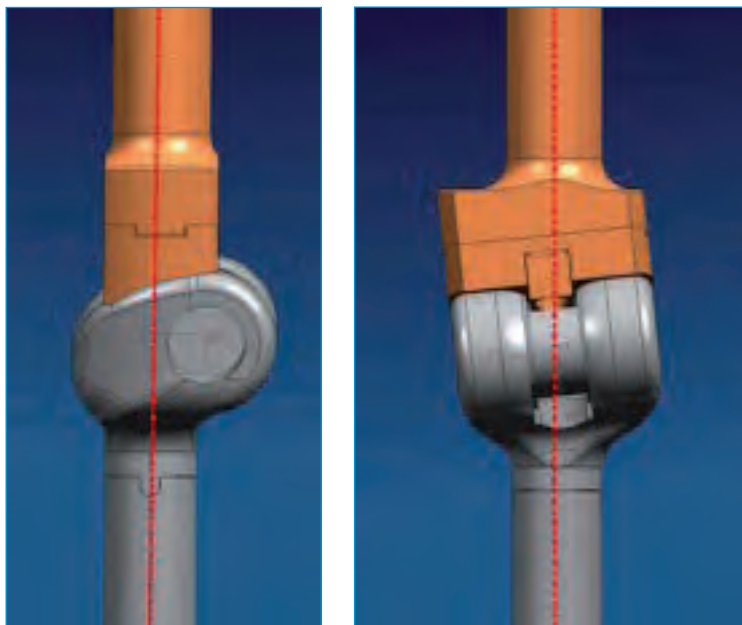

Its use enables taper engagement in axial alignment.

Assembly

The femur assembling protector is mounted as shown in below illustration. First the plate is connected to the handle so that, depending on the side being operated on, the letters “R” for the right side or the letters “L” for the left side are lined up. In the illustration the right side is chosen. Consecutively the block for assembling protector is secured using the hex screwdriver. The two arrows (of block and plate) must point toward each other.



340-200/01 Instrument Set for Patella Components, 3-pegs
for LINK Knee Family SL

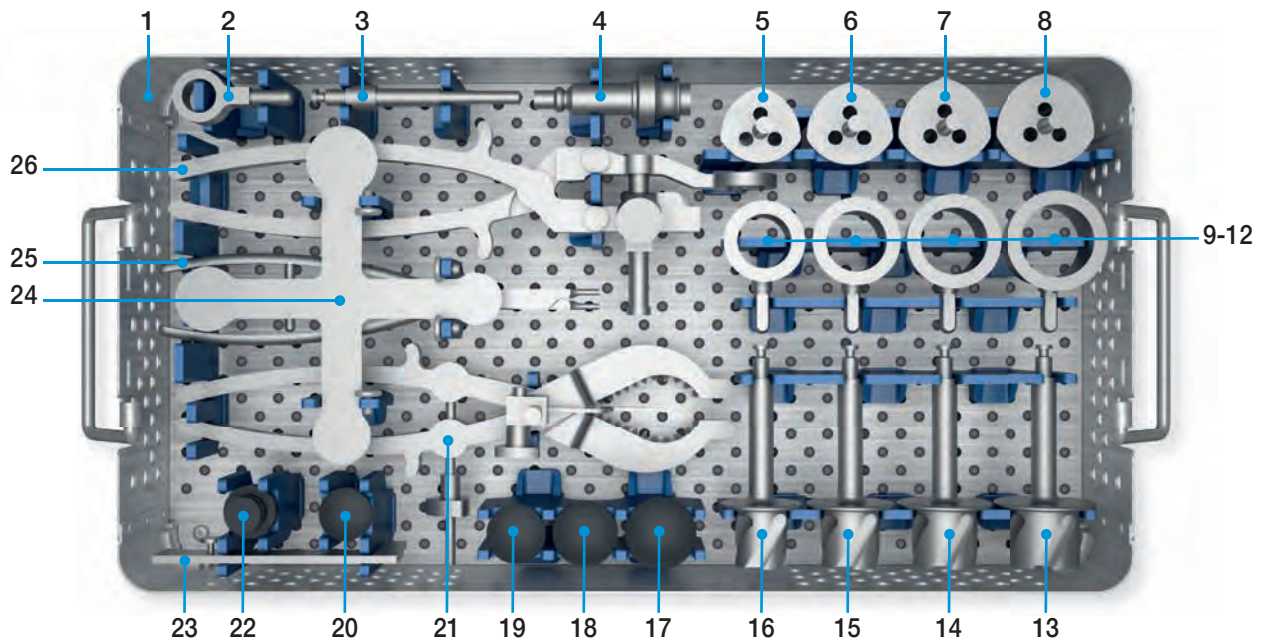



1	340-015/01	Tray, empty, 485 x 253 x 100 mm (incl. lid)
2	340-007	Patella Pusher Attachment
3	340-306B	Patella Drill, Ø 6.3 mm, with Hudson B fitting
4	optional*	Adapter for snap lock chuck, optional
		Patella Drill Guides for patella holding clamp
5	340-225	Size 25 for 318-401/25
6	340-228	Size 28 for 318-401/28
7	340-231	Size 31 for 318-401/31
8	340-234	Size 34 for 318-401/34
		Patella Reaming Guides for patella holding clamp
9	340-025	Size 25 for 318-401/25
10	340-028	Size 28 for 318-401/28
11	340-031	Size 31 for 318-401/31
12	340-034	Size 34 for 318-401/34
		Patella Reamers for patella reaming guides, with Hudson B fitting
13	340-134B	Size 34 for 318-401/34
14	340-131B	Size 31 for 318-401/31
15	340-128B	Size 28 for 318-401/28
16	340-125B	Size 25 for 318-401/25
		Patella Trial Prostheses for Patella Component 3-pegs
17	340-334	Size 34 for 318-401/34
18	340-331	Size 31 for 318-401/31
19	340-328	Size 28 for 318-401/28
20	340-325	Size 25 for 318-401/25
21	340-006	Patella Resection Clamp
22	340-009	Patella Pusher Inserter
23	65-2000	Townley Femur Caliper, 115 mm
24	340-010	Patella Sizing Template
25	15-2042	Inserting Forceps for inserting the manipulating bearings, 215 mm
26	340-005	Patella Holding Clamp

* Adapter optional: 16-3283/01, 16-3284/00, 16-3285/00

Additional Instruments

Adapter for Snap Lock Chuck with Hudson Fitting (B)

Various adapters to enable compatibility with other equipment connections.

Item no.	Fitting	
16-3283/01	Jacobs Fitting (E)	
16-3284/00	AO Fitting (D)	
16-3285/00	Harris Fitting (C)	

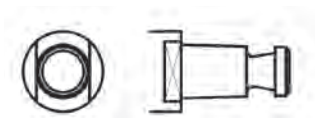





Hudson Fitting (B)
Basic tool connection

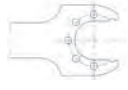

Sawblades,

without offset teeth, 1.24 mm thick

Wide (A) 25 mm	Wide (A) 13 mm	Fitting	
317-654/10	317-656/10	Synthes	
317-654/11	317-656/11	Aesculap combi	
317-654/13	317-656/13	Zimmer / Hall Kombi	
317-654/14	317-656/14	Stryker System 4	

Additional Instruments



Revision Drill Guide

for mobile and hinged version, to support the axis decoupling when changing the Endo-Model SL connection components

REF	complete
16-3295/00	consisting of 4 components: Retainer, Drill Rod, 2 Rods with handle



Extractor

for modular stems with female taper, taper 12/10 mm (for 3 mm + 6 mm noses)

REF	Length
15-0036/81	230 mm

Guide Rod with Slap Hammer

(without illustration)

(optional for stem extraction: Guide Rod 317-661 in combination with Driver Extractor 15-8516/45 or 15-0036/81)

REF	Length
317-661	365 mm

Hex Screwdriver,

hex 2.5 mm, 90°

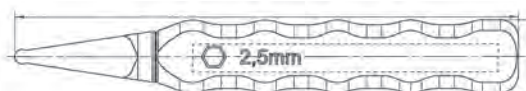

REF	Length
16-1230/00	139 mm

X-ray Templates

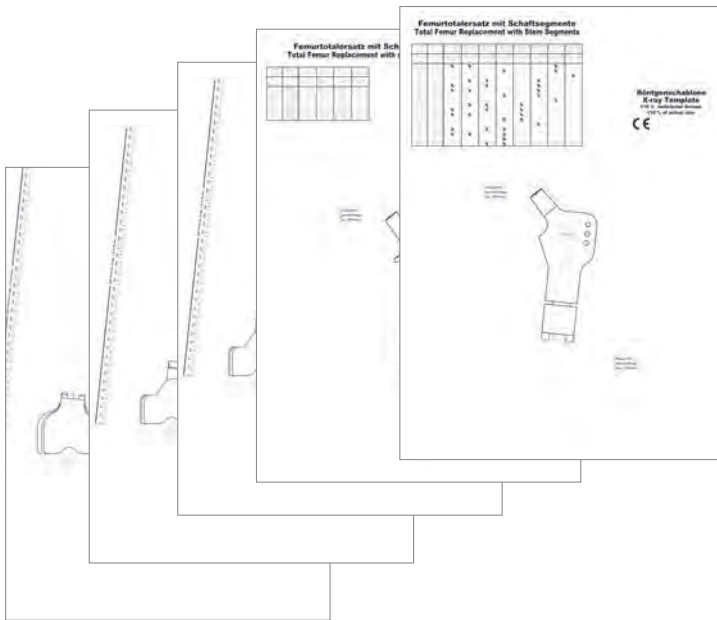

X-ray Templates,
110% of actual size, set = 22 sheets

Item no.	
15-8516/62	for LINK MEGASYSTEM-C with SL Knee Components

Surface Modifications (available as custom-made prosthesis on request)

a) Cementless Modular Stems PoroLink* optional with HX** coating.

- * PoroLink: grid blasted titanium surface Ra ~7µm
- ** HX: CaP = Calcium Phosphate coating

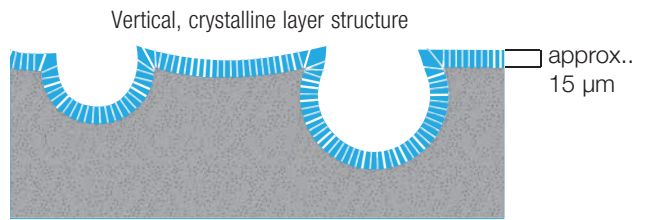

Fig.: PoroLink* with HX** coating. Schematic cross-section of coated surfaces.



b) Bone Replacement Components CoCrMo for metal hypersensitive patients, optional with LINK PorEx*** Technology.

*** LINK PorEx: TiNbN = Titanium Niobium Nitride

c) Bone Replacement Components (no intramedullary stems) with PorAg****

- **** PorAg: antimicrobial surface modification
- TiAgN/Ag = titanium silver nitride/silver surface modification

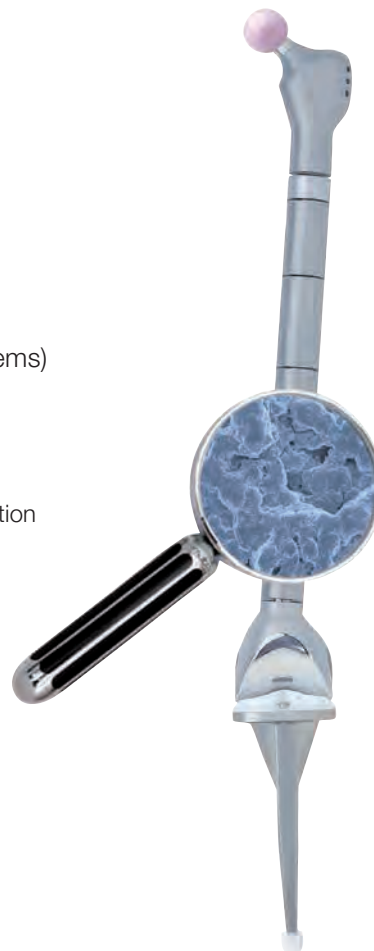



TrabecuLink Tibial Cones

- Surgical Technique
- Product Rationale
- Teaserflyer

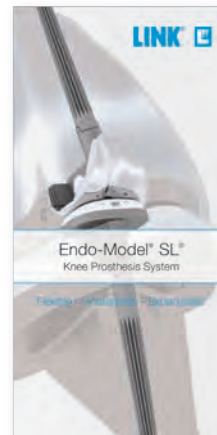
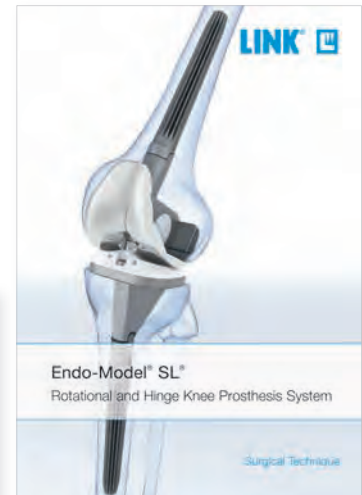
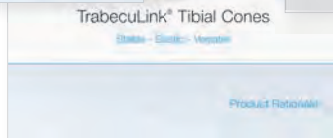

**Endo-Model SL
Rotational and Hinge
Knee Prosthesis System**

- Teaserflyer
- Surgical Technique

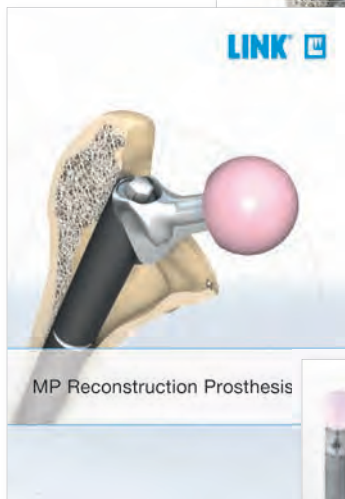
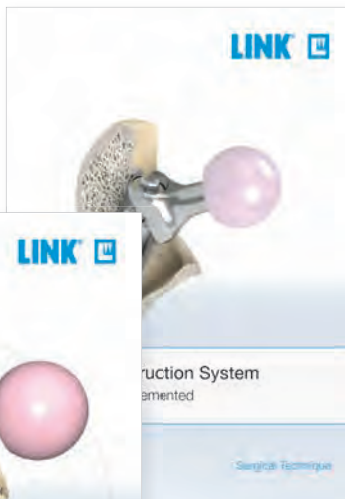

**MP Reconstruction
Prosthesis System**

- Surgical Technique
- Product Rationale
- Teaserflyer

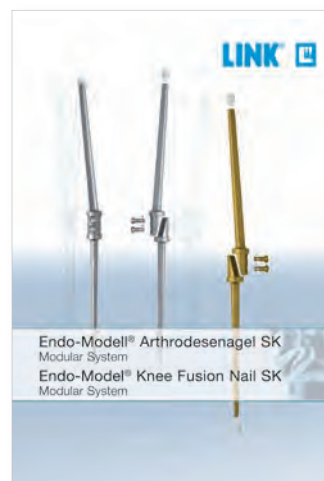

**Endo-Model
Knee Fusion Nail SK,**
• Modular System

LinkSpacer
PMMA/Gentamicin



Specified indications and contraindications:

<p>General Indications</p> <p>Mobility-limiting diseases, fractures or defects of the hip joint, the proximal and distal femur through the proximal tibia, in combination with Endo-Model SL rotational and hinge knee or modular as well as femoral use of Endo-Model–W und MP Neck Segments, which cannot be treated by conservative or osteosynthetic procedures.</p>
<p>Indications</p> <p>Revision arthroplasty due to juxta-articular bone defects.</p> <p>Revision of loosened femoral prosthesis components by peri-/subprosthetic fracture.</p> <p>Deformed proximal femur due to fractures or osteotomies.</p> <p>Bone deficiencies, e.g. due to tumors, as well as in large post-revision and post-trauma segmental bone defects.</p> <p>Oncological and revision surgery from tibial to hip area (in conjunction with Endo-Model SL Rotational and Hinge Knee Prostheses or modular as well as femoral use of Endo-Model–W and MP Neck Segments).</p>
<p>Contraindications</p> <p>Acute or chronic infections, local and systemic insofar as they compromise the successful implantation of a tumor- and revision endoprosthesis .</p> <p>Allergies to (implant) materials.</p> <p>For preparation of the prosthesis bearing insufficient length of intact diaphysis (less than 80 mm) in a planned distal or proximal femoral restoration.</p> <p>Distinctive muscular, nerve, vascular or other diseases which put the affected limb at risk.</p> <p>Insufficient bone integrity which prevents a stable anchorage of the prosthesis.</p>

Please note:

These indications/contraindications refer to standard cases. The ultimate decision on whether or not an implant is suitable for a patient must be made by the surgeon based on his/her individual analysis and his/her experience.

Please note the following regarding the use of our implants:

1. Choosing the right implant is very important.

The size and shape of the human bone determines the size and shape of the implant and also limits the load capacity. Implants are not designed to withstand unlimited physical stress. Demands should not exceed normal functional loads.

2. Correct handling of the implant is very important.

Under no circumstances should the shape of a finished implant be altered, as this shortens its life span. Our implants must not be combined with implants from other manufacturers. The instruments indicated in the Surgical Technique must be used to ensure safe implantation of the components.

3. Implants must not be reused.

Implants are supplied sterile and are intended for single use only. Used implants must not be used again.

4. After-treatment is also very important.

The patient must be informed of the limitations of the implant. The load capacity of an implant cannot compare with that of healthy bone!

5. Unless otherwise indicated, implants are supplied in sterile packaging.

Note the following conditions for storage of packaged implants:

- Avoid extreme or sudden changes in temperature.
- Sterile implants in their original, intact protective packaging may be stored in permanent buildings up until the "Use by" date indicated on the packaging.
- They must not be exposed to frost, dampness or direct sunlight, or mechanical damage.
- Implants may be stored in their original packaging for up to 5 years after the date of manufacture. The "Use by" date is indicated on the product label.
- Do not use an implant if the packaging is damaged.

6. Traceability is important.

Please use the documentation stickers provided to ensure traceability.

7. Further information on the material composition is available on request from the manufacturer.

Follow the instructions for use!

Waldemar Link GmbH & Co. KG, Hamburg

All content in this catalog, including text, pictures and data, is protected by law. Every instance of use, whether in part or in whole and which is not permitted by law, is subject to our prior consent. In particular, this applies to the reproduction, editing, translation, publishing, saving, processing, or passing on of content stored in databases or other electronic media and systems, in any manner or form. The information in the catalogs is solely intended to describe the products and does not constitute a guarantee.

The Surgical Technique described has been written to the best of our knowledge and belief, but it does not relieve the surgeon of his/her responsibility to duly consider the particularities of each individual case.

Products shown in this document may not be available in your country. The product availability is subject to the approval and/or registration regulations of the respective country. Please contact Waldemar Link GmbH & Co. KG if you have questions about the availability of LINK products in your country.

Waldemar Link GmbH & Co. KG and/or other corporate affiliated entities own, use or have applied for the following trademarks in many jurisdictions: LINK, BiMobile, SP II, Modell Lubinus, E-Dur, EndoDur, T.O.P. II, BetaCup, CombiCup PF, CombiCup SC, CombiCup R, MobileLink, C.F.P., LCU, SP-CL, LCP, MIT-H, Endo-Model, Endo-Model SL, MP, MEGASYSTEM-C, GEMINI SL, SPAR-K, LCK, Link OptiStem, HX, TiCaP, X-LINKed, PorAg, LINK PorEx, BiPorEx, PorEx-Z, TrabecuLink, Tilastan, customLINK, RescueSleeve, Stactip, VACUCAST.

Other trademarks and trade names may be used in this document to refer to either the entities claiming the marks and/or names or their products and are the property of their respective owners.

