

Earthing Terminal

Topraklama Klemensi

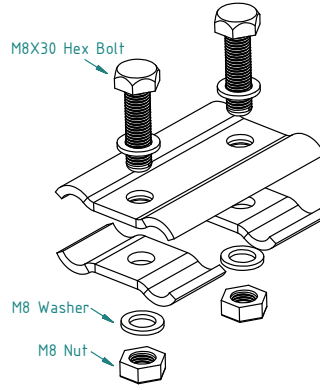

HDG-Steel, hot-dip galv. to TS-EN ISO 1461:2011 (HDG)

PS 1-1							
CODE	Height	Width	Thickness	Distances Between Circle Centers	Bolts & Nuts	Length	1 pc
	H mm	W mm	T mm	D mm	E Metric	L mm	
PS 1-1	35	40	3	28	M8 Hex nut & M8 Hex Bolt	72	0,153

Aluminium Earthing Terminal

Aluminyum Topraklama Klemensi

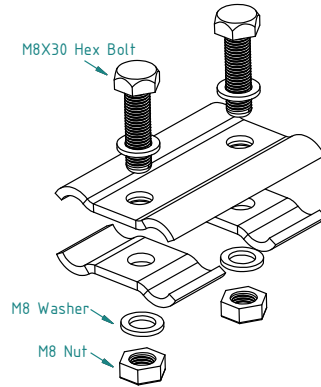

HDG-Steel, hot-dip galv. to TS-EN ISO 1461:2011 (HDG)

PS 2-1							
CODE	Height	Width	Thickness	Distances Between Circle Centers	Bolts & Nuts	Length	1 pc
	H mm	W mm	T mm	D mm	E Metric	L mm	
PS 2-1	35	50	3	34	M8 Hex nut & M8 Hex Bolt	72	0,182

Mounting Example

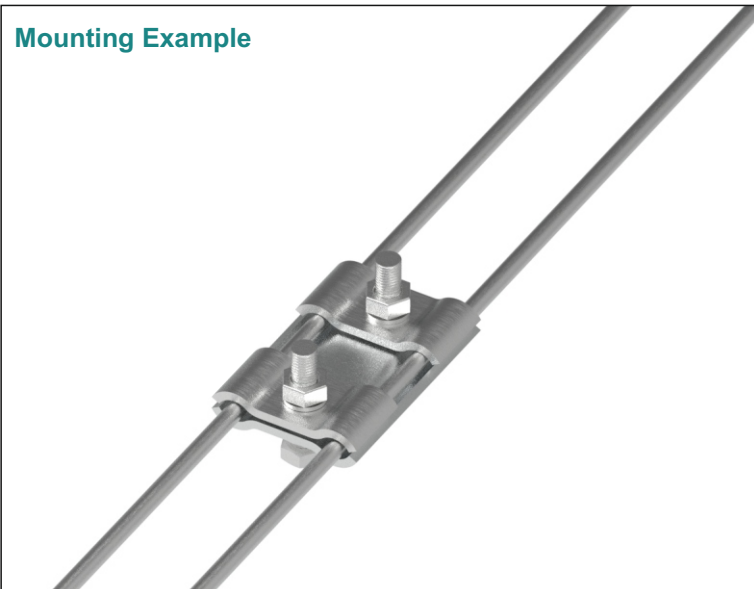

PS 1-1

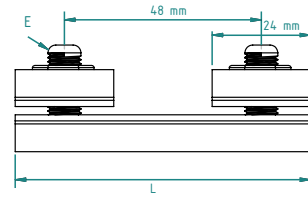
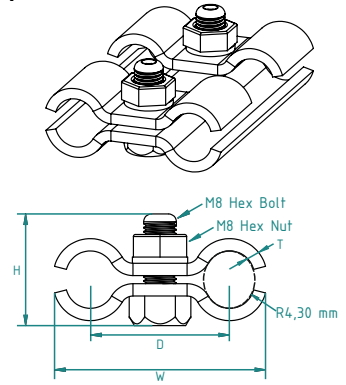

PS 2-1

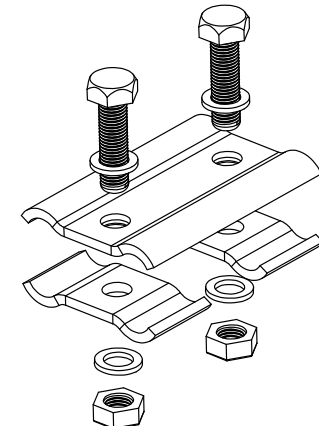
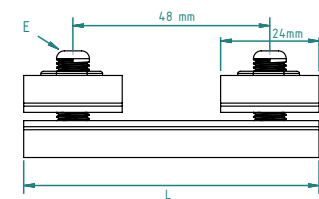
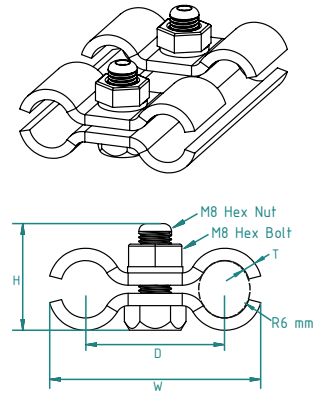

HDG-Steel, hot-dip galv. to TS-EN ISO 1461:2011 (HDG)
Steel: ST37 or S235JR / EN 10025-2