

**ANNEX 5,6 & 7**

**MANUFACTURER'S AUTHORIZATION**

Date: 06.12.2022

Tender Reference:

**Construcția apeductului magistral Sărata-Răzeși – Voinescu – Mingir din r-nul Hîncești (REPETAT)”**

MTender ID: **ocds-b3wdp1-MD-1669013317453**

To: **AGENȚIA DE DEZVOLTARE REGIONALA CENTRU**

We, **UT4FB CONTROL LTD**, based in Romania, Iasi, str. Islaz nr.41, legally represented by Mr. Tudor Ioan Ursache, as General Manager having production facilities in Romania, Iasi, str. Islaz nr.41, as manufacturer of:

- WASTEWATER PUMPING STATIONS AND MIXING SYSTEM
- COMPACT UNIT TREATMENTS
- FLOW CONTROL UNITS
- CONTAINERIZED PUMPING STATIONS FOR POTABLE WATER
- CONTAINERIZED AUTOMATIC DEZINFECTION STATIONS

We authorize consortium of companies **VEGAN-COM S.R.L. - PROSPERUS-CONS S.R.L** with the headquarters in Republic of Moldova, raion Straseni, or.Vorniceni str.E.Coca nr.6 and Republic of Moldova, mun.Chisinau, s.Hulboaca, str.Alba Iulia nr.5, to submit a complete offer which purpose is the supply of the above-mentioned products.

Innovation, professionalism, and quality of service are solid values that underlie our entire business.

**INOVATION** - We promote innovation at the heart of our strategy to create competitive and long-lasting solutions to increase customer profitability.

**PROFESSIONALISM** - We constantly invest in the professional development of our specialists. Know-how is the guarantee of the execution of any type of project, regardless of its complexity.

**QUALITY** - We use state-of-the-art equipment, state-of-the-art technology and products of the highest quality and durability.

We also agree that consortium of companies **VEGAN-COM S.R.L. - PROSPERUS-CONS S.R.L** shall submit to this tender the technical documentation, the sanitary certifications and approvals, the specific technical approvals and approvals to put into operation the products mentioned above.

Signed by: Mr. Tudor Ioan Ursache

as: General Manager

Signature: & Stamp:



Utilajul, echipamentul tehnologic: **Statia de dezinfectie containerizata automatizata s. Voinescu (Platforma B)**

Nr.crt.	Specificații tehnice impuse prin caietul de sarcini	Correspondența propunerii tehnice cu specificațiile tehnice impuse prin caietul de sarcini	Producător
1	<p><b>Parametri tehnici si functionali Container</b>                      Statia de dezinfectie a apei cu hipoclorit de sodiu va fi amplasata intr-un container, cu o singura incapere. cu dimensiunile 3500 x 2400 x 2700 mm. cu stilpi de sustinere profilati la rece din tabla zincata cu grosimea de min 2 mm. pereti din panou sandwich poliuretan tip C 1 RAL 9002 (garantat min 10 ani), acoperis cu rezistenta portanta de min 250 kg/m<sup>2</sup>, format din structura metalica zincata profilata la rece, grunduita reactiv si vopsita, tabla zincata dublu faltuita, grosime min 0,5 mm, folie anticondens, vata minerala grosime min 100 mm norma C1, tavan PVC RAL 9002. Accesul in container se va realiza printr-o usa laterala cu dimensiunile 900x2000 mm, PVC/metalia.</p> <p><b>Instalatii climatizare</b>                      Containerul va fi incalzit utilizind un convector electric cu termostat cu puterea de min 2000 W, cu montare pe perete. Pentru prevenirea aparitiei condensului si a supraincalzirii, va fi prevazut un ventilator axial, cu montare murala, cu functionare temporizata, cu debitul de min 1300 m<sup>3</sup>/h, 230 Va.c., max 60 W. Grila de admisie a aerului in zona tehnologica va fi montata in jumatatea inferioara a usii de acces sau pe peretele opus peretelui pe care se monteaza ventilatorul.</p> <p><b>Instalatii electrice</b>                      Statia de dezinfectie a apei cu hipoclorit de sodiu va fi prevazuta cu un singur tablou electric si de automatizare si control al procesului, cu dimensiunile max 800 x 260 x 600 mm..</p> <p>Tabloul electric va fi prevazut cu:</p>	<p><b>Parametri tehnici si functionali Container</b>                      Statia de dezinfectie a apei cu hipoclorit de sodiu va fi amplasata intr-un container, cu o singura incapere, cu dimensiunile 3500 x 2400 x 2700 mm. cu stilpi de sustinere profilati la rece din tabla zincata cu grosimea de min 2 mm. pereti din panou sandwich poliuretan tip C 1 RAL 9002 (garantat min 10 ani), acoperis cu rezistenta portanta de min 250 kg/m<sup>2</sup>, format din structura metalica zincata profilata la rece. grunduita reactiv si vopsita. tabla zincata dublu faltuita, grosime min 0,5 mm, folie anticondens, vata minerala grosime min 100 mm norma C1, tavan PVC RAL 9002. Accesul in container se va realiza printr-o usa laterala cu dimensiunile 900x2000 mm, PVC/metalia.</p> <p><b>Instalatii climatizare</b>                      Containerul va fi incalzit utilizind un convector electric cu termostat cu puterea de min 2000 W. cu montare pe perete. Pentru prevenirea aparitiei condensului si a supraincalzirii, va fi prevazut un ventilator axial, cu montare murala, cu functionare temporizata, cu debitul de min 1300 m<sup>3</sup>/h, 230 Va.c., max 60 W. Grila de admisie a aerului in zona tehnologica va fi montata in jumatatea inferioara a usii de acces sau pe peretele opus peretelui pe care se monteaza ventilatorul.</p> <p><b>Instalatii electrice</b>                      Statia de dezinfectie a apei cu hipoclorit de sodiu va fi prevazuta cu un singur tablou electric si de automatizare si control al procesului. cu dimensiunile max 800 x 260 x 600 mm..</p> <p>Tabloul electric va fi prevazut cu:</p>	<p>UT4FB CONTROL LTD</p>

Utilajul, echipamentul tehnologic: **Statia de dezinfectie containerizata automatizata s. Voinescu (Platforma B)**

<p>- inversor manual de sursa, pentru posibilitatea conectarii unui grup generator portabil (in sursa 1 se va conecta alimentarea din reseaua electrica, iar in sursa 2 se va conecta o fisa industriala monofazata (230 V), montata aparent pe peretele exterior al tabloului electric);</p> <p>- echipamente pentru protectia si comanda dozatoarelor de hipoclorit;</p> <p>- echipamente de protectie pentru debitmetre;</p> <p>- sigurante automate diferentiale pentru circuitele de iluminat si incalzire;</p> <p>- priza 230 Vc.a. monofazata pentru serviciile interne;</p> <p>- modul de protectie la supratensiuni atmosferice si de comutatie;</p> <p>Pentru iluminatul statiei de clorinare se va utiliza o lampa cu LED, max 30 W, 3500 lm, 4000 K, 230 Vc.a., IP65, IK08.</p> <p>Instalatii tehnologice</p> <p>Se va instala o linie de masurare a debitului si de injectie a hipocloritului, care va fi prevazuta cu urmatoarele echipamente:</p> <p>- robinet de izolare la intrare;</p> <p>- debitmetru (cu tronsoanele amonte si aval necesare);</p> <p>- sistem de analiza clor rezidual in timp real;</p> <p>- sistem de dozare hipoclorit;</p> <p>- robinet actionat electric la iesirea liniei controlat de senzori de nivel din cadrul castelului de apa potabila;</p> <p>- senzorii de nicel (min 3 buc.);</p> <p>- lavoar total echipat pentru spalare ochi in caz de incident;</p> <p>- sifon de pardoseala.</p> <p>Linia de masura se va realiza utilizand conducte din otel inoxidabil.</p> <p>Caracteristici statii de dezinfectie a apei cu hipoclorit de sodiu localitatea Voinescu:</p> <ul style="list-style-type: none"> <li><input type="checkbox"/> dimensiuni container: 3500 x 2400 x 2700;</li> <li><input type="checkbox"/> diametru intrare: Dn65 (PEHD De75);</li> <li><input type="checkbox"/> diametru iesire: Dn65 (PEHD De75);</li> <li><input type="checkbox"/> debitmetru: Dn50.</li> </ul>	<p>- inversor manual de sursa, pentru posibilitatea conectarii unui grup generator portabil (in sursa 1 se va conecta alimentarea din reseaua electrica, iar in sursa 2 se va conecta o fisa industriala monofazata (230 V), montata aparent pe peretele exterior al tabloului electric);</p> <p>- echipamente pentru protectia si comanda dozatoarelor de hipoclorit;</p> <p>- echipamente de protectie pentru debitmetre;</p> <p>- sigurante automate diferentiale pentru circuitele de iluminat si incalzire;</p> <p>- priza 230 Vc.a. monofazata pentru serviciile interne;</p> <p>- modul de protectie la supratensiuni atmosferice si de comutatie;</p> <p>Pentru iluminatul statiei de clorinare se va utiliza o lampa cu LED, max 30 W, 3500 lm, 4000 K, 230 Vc.a., IP65, IK08.</p> <p>Instalatii tehnologice</p> <p>Se va instala o linie de masurare a debitului si de injectie a hipocloritului, care va fi prevazuta cu urmatoarele echipamente:</p> <p>- robinet de izolare la intrare;</p> <p>- debitmetru (cu tronsoanele amonte si aval necesare);</p> <p>- sistem de analiza clor rezidual in timp real;</p> <p>- sistem de dozare hipoclorit;</p> <p>- robinet actionat electric la iesirea liniei controlat de senzori de nivel din cadrul castelului de apa potabila;</p> <p>- senzorii de nicel (min 3 buc.);</p> <p>- lavoar total echipat pentru spalare ochi in caz de incident;</p> <p>- sifon de pardoseala.</p> <p>Linia de masura se va realiza utilizand conducte din otel inoxidabil.</p> <p>Caracteristici statii de dezinfectie a apei cu hipoclorit de sodiu localitatea Voinescu:</p> <ul style="list-style-type: none"> <li><input type="checkbox"/> dimensiuni container: 3500 x 2400 x 2700;</li> <li><input type="checkbox"/> diametru intrare: Dn65 (PEHD De75);</li> <li><input type="checkbox"/> diametru iesire: Dn65 (PEHD De75);</li> <li><input type="checkbox"/> debitmetru: Dn50.</li> </ul>	
---	---	--

Utilajul, echipamentul tehnologic: **Statia de dezinfectie containerizata automatizata s. Voinescu (Platforma B)**

<p>Masurarea debitelor  Caracteristici debitmetru:  - principiul de masurare: inductie electromagnetica;  - conectarea la proces: flansa EN 1092-1;  - grad de protectie: IP 67;  - carcasa si flanse: otel carbon, acoperire anticoroziune cu vopsea epoxidica (min. 150 µm);  - teava de masura: inox AISI 304/1.4301;  - electrozi: hastelloy C;  - transmiter, montaj compact, precizie de masurare ± 0,4 %, o iesire analogica 4÷20mA, o iesire digitala, o iesire pe releu, display retroiluminat cu text alfanumeric 3x20 caractere, IP67, alimentare 115-230 Vc.a., temperatura de operare - 20÷50 °C. Corectia concentratiei de clor in apa  In statia de dezinfectie a apei cu hipoclorit de sodiu se va face o corectie a concentratiei de clor din apa in functie de concentratia de clor din conducta de aspiratie si debitul vehiculat.  Caracteristici sistem analiza clor rezidual:  - alimentare: 220 Vc.a.;  - sistem preasamblat al unitatii de control si al celulei de masura (instalare pe perete);  - sistem de prelevare a probei de apa pentru analiza concentratiei de clor rezidual;  - masurarea si controlul continuu a concentratiei clorului rezidual, cu posibilitatea de compensare a temperaturii;  - gama de masura a clorului rezidual: 0÷2 mg/l;  - senzor de temperatura a apei;  - presiune maxima de lucru: 3 bar.  Sistem de dozare: se va instala un sistem de dozare pe conducta de refulare.  Componenta sistem de dozare:  - pompa dozatoare digitala, cu functionare automata in functie de debitul apei pompate si de valoarea clorului rezidual masurata de instalatia de analiza;</p>	<p>Masurarea debitelor  Caracteristici debitmetru:  - principiul de masurare: inductie electromagnetica;  - conectarea la proces: flansa EN 1092-1;  - grad de protectie: IP 67;  - carcasa si flanse: otel carbon, acoperire anticoroziune cu vopsea epoxidica (min. 150 µm);  - teava de masura: inox AISI 304/1.4301;  - electrozi: hastelloy C;  - transmiter, montaj compact, precizie de masurare ± 0,4 %, o iesire analogica 4÷20mA, o iesire digitala, o iesire pe releu, display retroiluminat cu text alfanumeric 3x20 caractere, IP67, alimentare 115-230 Vc.a., temperatura de operare - 20÷50 °C. Corectia concentratiei de clor in apa  In statia de dezinfectie a apei cu hipoclorit de sodiu se va face o corectie a concentratiei de clor din apa in functie de concentratia de clor din conducta de aspiratie si debitul vehiculat.  Caracteristici sistem analiza clor rezidual:  - alimentare: 220 Vc.a.;  - sistem preasamblat al unitatii de control si al celulei de masura (instalare pe perete);  - sistem de prelevare a probei de apa pentru analiza concentratiei de clor rezidual;  - masurarea si controlul continuu a concentratiei clorului rezidual, cu posibilitatea de compensare a temperaturii;  - gama de masura a clorului rezidual: 0÷2 mg/l;  - senzor de temperatura a apei;  - presiune maxima de lucru: 3 bar.  Sistem de dozare: se va instala un sistem de dozare pe conducta de refulare.  Componenta sistem de dozare:  - pompa dozatoare digitala, cu functionare automata in functie de debitul apei pompate si de valoarea clorului rezidual masurata de instalatia de analiza;</p>	
--	--	--

**Utilajul, echipamentul tehnologic: Statia de dezinfectie containerizata automatizata s. Voinescu (Platforma B)**

<ul style="list-style-type: none"> <li>- dozatorul va avea intrari si iesiri digitale (pentru comanda si citire stare pompa dozatoare), precum si intrari si iesiri analogice, 4÷20mA (pentru prescrierea referintei, respectiv, citirea reactiei dozatorului de clor);</li> <li>- rezervor de stocare solutie de hipoclorit, min 200 litri, material PE, prevazut cu robinet de golire;</li> <li>- agitator manual;</li> <li>- linie de aspiratie rigida, cu: sorb aspiratie, clapeta de sens si senzor de rezervor gol;</li> <li>- supapa multifunctionala, pentru: prevenirea sifonarii, mentinerea constanta a contrapresiunii si reducerea manuala a presiunii;</li> <li>- furtun dozare hipoclorit;</li> <li>- unitate de injectie hipoclorit, cu supapa pentru prevenirea cristalizarii si blocarii dozarii hipocloritului in apa care are un continut ridicat de carbonati.</li> </ul> <p>Caracteristici pompa dozatoare:</p> <ul style="list-style-type: none"> <li>- alimentare: 220 Vc.a.;</li> <li>- debit maxim 7.5 l/h si debit minim 2,5 ml/h;</li> <li>- presiune de lucru: max. 16 bari;</li> <li>- meniu de lucru in limba romana;</li> <li>- afisaj LCD, cu iluminarea fundalului in culori specifice starii de functionare;</li> <li>- sistem de auto-dezaerare;</li> <li>- sistem de auto-adaptare;</li> <li>- senzor de monitorizare a presiunii;</li> <li>- afisare informatii de service;</li> <li>- relee de iesire semnal (programabile);</li> <li>- suport (placa) de montaj inclusa;</li> <li>- modul de interfatare comunicatie SCADA (Modbus-RTU TCP, Profinet).</li> </ul> <p>Echipamente de automatizare Pentru monitorizarea/controlul parametrilor procesului tehnologic, precum si pentru comunicatia cu sistemul</p>	<ul style="list-style-type: none"> <li>- dozatorul va avea intrari si iesiri digitale (pentru comanda si citire stare pompa dozatoare), precum si intrari si iesiri analogice, 4÷20mA (pentru prescrierea referintei, respectiv, citirea reactiei dozatorului de clor);</li> <li>- rezervor de stocare solutie de hipoclorit, min 200 litri, material PE, prevazut cu robinet de golire;</li> <li>- agitator manual;</li> <li>- linie de aspiratie rigida, cu: sorb aspiratie, clapeta de sens si senzor de rezervor gol;</li> <li>- supapa multifunctionala, pentru: prevenirea sifonarii, mentinerea constanta a contrapresiunii si reducerea manuala a presiunii;</li> <li>- furtun dozare hipoclorit;</li> <li>- unitate de injectie hipoclorit, cu supapa pentru prevenirea cristalizarii si blocarii dozarii hipocloritului in apa care are un continut ridicat de carbonati.</li> </ul> <p>Caracteristici pompa dozatoare:</p> <ul style="list-style-type: none"> <li>- alimentare: 220 Vc.a.;</li> <li>- debit maxim 7.5 l/h si debit minim 2,5 ml/h;</li> <li>- presiune de lucru: max. 16 bari;</li> <li>- meniu de lucru in limba romana;</li> <li>- afisaj LCD, cu iluminarea fundalului in culori specifice starii de functionare;</li> <li>- sistem de auto-dezaerare;</li> <li>- sistem de auto-adaptare;</li> <li>- senzor de monitorizare a presiunii;</li> <li>- afisare informatii de service;</li> <li>- relee de iesire semnal (programabile);</li> <li>- suport (placa) de montaj inclusa;</li> <li>- modul de interfatare comunicatie SCADA (Modbus-RTU TCP, Profinet).</li> </ul> <p>Echipamente de automatizare Pentru monitorizarea/controlul parametrilor procesului tehnologic, precum si pentru comunicatia cu sistemul</p>	
--	--	--

Utilajul, echipamentul tehnologic: **Statia de dezinfectie containerizata automatizata s. Voinescu (Platforma B)**

<p>SCADA, in tabloul electric si de automatizare se va prevedea un PLC cu router GSM/GPRS integrat. Pe usa tabloului electric va fi amplasat un afisaj pentru urmarirea parametrilor procesului de catre operator, precum si pentru programarea valorilor de referinta.</p> <p>Caracteristicile PLC-ului:</p> <ul style="list-style-type: none"> <li>- procesor: 64 MHz;</li> <li>- memorie program: 512 kByte;</li> <li>- memorie nevolatila retentiva: 48 kByte (NVRAM);</li> <li>- memorie de stocare: 512 kByte;</li> <li>- ceas de timp real;</li> <li>- alimentare: 24 Vc.c. (19,2÷30 Vc.c.);</li> <li>- consumul tipic de curent: 210 mA;</li> <li>- curent maxim consumat: 860 mA (360 mA – comunicare + 500 mA – alimentare I/O analogice);</li> <li>- cantitatea de date de proces suportata: max. 4096 Bit (INTERBUS);</li> <li>- numarul de dispozitive suportate: max. 128;</li> <li>- numarul de dispozitive locale care pot fi conectate: max. 63;</li> <li>- limbaje de programare conform IEC 61631-3 (LD, FBD, ST, IL);</li> <li>- optiuni comunicare: Ethernet (10/100 Mbit/s), RS485, RS422;</li> <li>- router GSM/GPRS integrat. port card SIM, conexiune antena SMA;</li> <li>- grad de protectie: IP20;</li> <li>- temperatura ambientala operare/transport-depozitare: -25 ÷ +55 °C / -25 ÷ +85 °C;</li> <li>- umiditate permisa operare/transport-depozitare: 10 ÷ 95 %;</li> <li>- presiunea aerului: 70 ÷ 106 kPa (max. 3000 m deasupra nivelului marii);</li> <li>- port pentru card SD (max. 2 GB);</li> <li>- webserver integrat;</li> <li>- 16 intrari digitale (conectare 2, 3, 4 conductoare, tip NPN/PNP EN 61131-2) si 4</li> </ul>	<p>SCADA, in tabloul electric si de automatizare se va prevedea un PLC cu router GSM/GPRS integrat. Pe usa tabloului electric va fi amplasat un afisaj pentru urmarirea parametrilor procesului de catre operator, precum si pentru programarea valorilor de referinta.</p> <p>Caracteristicile PLC-ului:</p> <ul style="list-style-type: none"> <li>- procesor: 64 MHz;</li> <li>- memorie program: 512 kByte;</li> <li>- memorie nevolatila retentiva: 48 kByte (NVRAM);</li> <li>- memorie de stocare: 512 kByte;</li> <li>- ceas de timp real;</li> <li>- alimentare: 24 Vc.c. (19,2÷30 Vc.c.);</li> <li>- consumul tipic de curent: 210 mA;</li> <li>- curent maxim consumat: 860 mA (360 mA – comunicare + 500 mA – alimentare I/O analogice);</li> <li>- cantitatea de date de proces suportata: max. 4096 Bit (INTERBUS);</li> <li>- numarul de dispozitive suportate: max. 128;</li> <li>- numarul de dispozitive locale care pot fi conectate: max. 63;</li> <li>- limbaje de programare conform IEC 61631-3 (LD, FBD, ST, IL);</li> <li>- optiuni comunicare: Ethernet (10/100 Mbit/s), RS485, RS422;</li> <li>- router GSM/GPRS integrat. port card SIM, conexiune antena SMA;</li> <li>- grad de protectie: IP20;</li> <li>- temperatura ambientala operare/transport-depozitare: -25 ÷ +55 °C / -25 ÷ +85 °C;</li> <li>- umiditate permisa operare/transport-depozitare: 10 ÷ 95 %;</li> <li>- presiunea aerului: 70 ÷ 106 kPa (max. 3000 m deasupra nivelului marii);</li> <li>- port pentru card SD (max. 2 GB);</li> <li>- webserver integrat;</li> <li>- 16 intrari digitale (conectare 2, 3, 4 conductoare, tip NPN/PNP EN 61131-2) si 4</li> </ul>	
--	--	--

**Utilajul, echipamentul tehnologic: Statia de dezinfectie containerizata automatizata s. Voinescu (Platforma B)**

<p>iesiri digitale (conectare 2, 3, 4 conductoare, consum maxim pe canal 500 mA) integrate.  Modul cu 8 intrari digitale:  - alimentare: 19,2÷30 Vc.c.);  - consum curent: max. 30 mA;  - consum putere: max. 0,25 W;  - LED-uri semnalizare stare intrari;  - timp tipic de raspuns: 1 ms;  - tensiune de intrare pentru semnal „0”: -3 ÷ +5 Vc.c.;  - tensiune de intrare pentru semnal „1”: 11 ÷ 30 Vc.c.  Modul cu 8 iesiri digitale:  - sarcina inductiva nominala: 12 VA (1,2 H; 50 Ω);  - sarcina rezistiva nominala: 12 W (48 Ω);  - curentul maxim de iesire per canal: 500 mA;  - tensiune de iesire: 24 Vc.c.;  - protectie la suprasarcina si scurtcircuit;  - tensiune de alimentare: 24 Vc.c. (19,2÷30 Vc.c.);  - consum de curent: max. 45 mA;  - consum de putere: max. 0,34 W;  - LED-uri semnalizare stare iesiri.  Modul cu 4 intrari analogice in curent (0/4 ÷ 20 mA):  - timp de conversie analogic/digital: max. 6,5 μs;  - rezolutie analogic/digital: 12 bit;  - consum curent: 55 mA;</p> <p>Panou operator:  - diagonala: minim 17,8 cm/7”;  - rezolutie: 800 x 480 pixeli (WVGA);  - tehnologie touch: rezistiv;  - iluminare fundal: LED;  - MTBF: 20000 h;  - numar culori: 262144  - procesor: 454 MHz;  - sistem de operare: MS Windows® CE 6.0;  - memorie RAM: 128 MB SDRAM;</p>	<p>iesiri digitale (conectare 2, 3, 4 conductoare, consum maxim pe canal 500 mA) integrate.  Modul cu 8 intrari digitale:  - alimentare: 19,2÷30 Vc.c.);  - consum curent: max. 30 mA;  - consum putere: max. 0,25 W;  - LED-uri semnalizare stare intrari;  - timp tipic de raspuns: 1 ms;  - tensiune de intrare pentru semnal „0”: -3 ÷ +5 Vc.c.;  - tensiune de intrare pentru semnal „1”: 11 ÷ 30 Vc.c.  Modul cu 8 iesiri digitale:  - sarcina inductiva nominala: 12 VA (1,2 H; 50 Ω);  - sarcina rezistiva nominala: 12 W (48 Ω);  - curentul maxim de iesire per canal: 500 mA;  - tensiune de iesire: 24 Vc.c.;  - protectie la suprasarcina si scurtcircuit;  - tensiune de alimentare: 24 Vc.c. (19,2÷30 Vc.c.);  - consum de curent: max. 45 mA;  - consum de putere: max. 0,34 W;  - LED-uri semnalizare stare iesiri.  Modul cu 4 intrari analogice in curent (0/4 ÷ 20 mA):  - timp de conversie analogic/digital: max. 6,5 μs;  - rezolutie analogic/digital: 12 bit;  - consum curent: 55 mA;</p> <p>Panou operator:  - diagonala: minim 17,8 cm/7”;  - rezolutie: 800 x 480 pixeli (WVGA);  - tehnologie touch: rezistiv;  - iluminare fundal: LED;  - MTBF: 20000 h;  - numar culori: 262144  - procesor: 454 MHz;  - sistem de operare: MS Windows® CE 6.0;  - memorie RAM: 128 MB SDRAM;</p>	
--	--	--



Utilajul, echipamentul tehnologic: **Statia de dezinfectie containerizata automatizata s. Voinescu (Platforma B)**

<ul style="list-style-type: none"> <li>- interfata: 1 x Ethernet (10/100 Mbps, RJ45), 2 x RS-232/422/485, 1 x USB tip A, 1 x USB tip B, 1 x SD;</li> <li>- tensiune de alimentare: 24 Vc.c. <math>\pm 15\%</math>;</li> <li>- curent consumat: 0,4 A;</li> <li>- grad de protectie: IP 66 (fata), IP 20 (spate);</li> <li>- temperatura ambientală operare/depozitare-transport: 0 ÷ 50 °C / -20 ÷ +85 °C;</li> <li>- umeditate permisa operare/transport-depozitare: 10 ÷ 95 %.</li> </ul> <p>Sursa cu UPS integrat:</p> <ul style="list-style-type: none"> <li>- tensiune de intrare: 85 ÷ 264 Vc.a. / 100 ÷ 350 Vc.a.;</li> <li>- consum curent: 1,8 A la 230 Vc.a. / 1,8 A la 120 Vc.a.;</li> <li>- factor de putere: aprox. 0,5</li> <li>- curent limita de pornire in sarcina/I2t: &lt; 1,3 A2s;</li> <li>- timp tipic de raspuns: 150 ms (230 Vc.a.) / 200 ms (120 Vc.a.);</li> <li>- circuit de protectie: varistor integrat pentru protectia la regim tranzitoriu;</li> <li>- siguranta intrare: 6,3 A, integrate;</li> <li>- tensiune nominala de iesire: 24 Vc.c.;</li> <li>- curent nominal de iesire: 5 A (-25 ÷ 55°C);</li> <li>- curent maxim de iesire: 6 A;</li> <li>- scadere curent de iesire cu temperatura: 2,5%/K pentru 55 ÷ 70 °C;</li> <li>- eficienta: &gt; 88 % (230 Vc.a., alimentare din retea); &gt; 86 % (120 Vc.a., alimentare din retea); &gt; 86 % (alimentare din baterie);</li> <li>- component alternativ in curentul de iesire: &lt; 10 mVPP;</li> <li>- conectare in paralel: da, 2 dispozitive;</li> <li>- baterii externe acceptate: 1,3 Ah / 3,4 Ah / 7,2 Ah / 12 Ah;</li> <li>- caracteristica de incarcare: curba caracteristica I/U;</li> <li>- curent de incarcare: 0,2 A ÷ 1,5 A (implicit 1,0 A);</li> <li>- compensarea temperaturii: 0 ÷ 200 mV/K (implicit 42 mV/K);</li> <li>- interval verificare baterie: 4 h ÷ 200 h (implicit 12 h);</li> <li>- montaj: sina DIN;</li> </ul>	<ul style="list-style-type: none"> <li>- interfata: 1 x Ethernet (10/100 Mbps, RJ45), 2 x RS-232/422/485, 1 x USB tip A, 1 x USB tip B, 1 x SD;</li> <li>- tensiune de alimentare: 24 Vc.c. <math>\pm 15\%</math>;</li> <li>- curent consumat: 0,4 A;</li> <li>- grad de protectie: IP 66 (fata), IP 20 (spate);</li> <li>- temperatura ambientală operare/depozitare-transport: 0 ÷ 50 °C / -20 ÷ +85 °C;</li> <li>- umeditate permisa operare/transport-depozitare: 10 ÷ 95 %.</li> </ul> <p>Sursa cu UPS integrat:</p> <ul style="list-style-type: none"> <li>- tensiune de intrare: 85 ÷ 264 Vc.a. / 100 ÷ 350 Vc.a.;</li> <li>- consum curent: 1,8 A la 230 Vc.a. / 1,8 A la 120 Vc.a.;</li> <li>- factor de putere: aprox. 0,5</li> <li>- curent limita de pornire in sarcina/I2t: &lt; 1,3 A2s;</li> <li>- timp tipic de raspuns: 150 ms (230 Vc.a.) / 200 ms (120 Vc.a.);</li> <li>- circuit de protectie: varistor integrat pentru protectia la regim tranzitoriu;</li> <li>- siguranta intrare: 6,3 A, integrate;</li> <li>- tensiune nominala de iesire: 24 Vc.c.;</li> <li>- curent nominal de iesire: 5 A (-25 ÷ 55°C);</li> <li>- curent maxim de iesire: 6 A;</li> <li>- scadere curent de iesire cu temperatura: 2,5%/K pentru 55 ÷ 70 °C;</li> <li>- eficienta: &gt; 88 % (230 Vc.a., alimentare din retea); &gt; 86 % (120 Vc.a., alimentare din retea); &gt; 86 % (alimentare din baterie);</li> <li>- component alternativ in curentul de iesire: &lt; 10 mVPP;</li> <li>- conectare in paralel: da, 2 dispozitive;</li> <li>- baterii externe acceptate: 1,3 Ah / 3,4 Ah / 7,2 Ah / 12 Ah;</li> <li>- caracteristica de incarcare: curba caracteristica I/U;</li> <li>- curent de incarcare: 0,2 A ÷ 1,5 A (implicit 1,0 A);</li> <li>- compensarea temperaturii: 0 ÷ 200 mV/K (implicit 42 mV/K);</li> <li>- interval verificare baterie: 4 h ÷ 200 h (implicit 12 h);</li> <li>- montaj: sina DIN;</li> </ul>	
--	--	--

Utilajul, echipamentul tehnologic: **Statia de dezinfectie containerizata automatizata s. Voinescu (Platforma B)**

<ul style="list-style-type: none"> <li>- MTBF (IEC 61709, SN 29500): &gt; 596000 h (40 °C);</li> <li>- compatibilitate electromagnetica: in conformitate cu directive EMC 2004/108/EC;</li> <li>- emisie zgomot: EN 55011 (EN 55022);</li> <li>- directiva joasa tensiune: 2006/95/EC;</li> <li>- clasa de protectie: I;</li> <li>- grad de protectie: IP20;</li> <li>- temperatura ambientala operare: -25 ÷ +70 °C;</li> <li>- umeditate permisa operare: 95 % (la 20 °C, fara condens).</li> </ul> <p>Contor de energie</p> <ul style="list-style-type: none"> <li>- temperatura ambientala operare: -10 ÷ +55 °C;</li> <li>- umeditate permisa operare: 80 % (pina la 31 °C);</li> <li>- grad de protectie: IP52 (fata), IP30 (spate);</li> <li>- afisaj: LCD, iluminat;</li> <li>- tensiune de alimentare: 110 ÷ 400 Vc.a. ± 10 %;</li> <li>- putere nominala consumata: 5 VA;</li> <li>- putere maxima consumata cu toate modulele de extensie: 10 VA;</li> <li>- conformitate: CE;</li> <li>- principiul de masurare: valoare R.M.S;</li> <li>- armonici: pina la armonica 51;</li> <li>- precizie: 0,2%;</li> <li>- domeniul de masura: 50 ÷ 500 Vc.a. (faza/faza), 28 ÷ 289 Vc.a. (faza/neutru);</li> <li>- frecventa: 50 ÷ 60 Hz;</li> <li>- masurarea se realizeaza cu transformatoare externe;</li> <li>- energie activa (IEC 62053-22): clasa 0,5 S;</li> <li>- putere reactiva (IEC 62053-23): clasa 2;</li> <li>- modul de comunicatie: RS 485.</li> </ul> <p>Comunicare cu dispeceratul SCADA          Tabloul electric si de automatizare va prelua datele din statia de clorinare si va comunica prin GPRS (protocol Modbus TCP) cu dispeceratul SCADA de la SA „APA CANAL” LEOVA.</p>	<ul style="list-style-type: none"> <li>- MTBF (IEC 61709, SN 29500): &gt; 596000 h (40 °C);</li> <li>- compatibilitate electromagnetica: in conformitate cu directive EMC 2004/108/EC;</li> <li>- emisie zgomot: EN 55011 (EN 55022);</li> <li>- directiva joasa tensiune: 2006/95/EC;</li> <li>- clasa de protectie: I;</li> <li>- grad de protectie: IP20;</li> <li>- temperatura ambientala operare: -25 ÷ +70 °C;</li> <li>- umeditate permisa operare: 95 % (la 20 °C, fara condens).</li> </ul> <p>Contor de energie</p> <ul style="list-style-type: none"> <li>- temperatura ambientala operare: -10 ÷ +55 °C;</li> <li>- umeditate permisa operare: 80 % (pina la 31 °C);</li> <li>- grad de protectie: IP52 (fata), IP30 (spate);</li> <li>- afisaj: LCD, iluminat;</li> <li>- tensiune de alimentare: 110 ÷ 400 Vc.a. ± 10 %;</li> <li>- putere nominala consumata: 5 VA;</li> <li>- putere maxima consumata cu toate modulele de extensie: 10 VA;</li> <li>- conformitate: CE;</li> <li>- principiul de masurare: valoare R.M.S;</li> <li>- armonici: pina la armonica 51;</li> <li>- precizie: 0,2%;</li> <li>- domeniul de masura: 50 ÷ 500 Vc.a. (faza/faza), 28 ÷ 289 Vc.a. (faza/neutru);</li> <li>- frecventa: 50 ÷ 60 Hz;</li> <li>- masurarea se realizeaza cu transformatoare externe;</li> <li>- energie activa (IEC 62053-22): clasa 0,5 S;</li> <li>- putere reactiva (IEC 62053-23): clasa 2;</li> <li>- modul de comunicatie: RS 485.</li> </ul> <p>Comunicare cu dispeceratul SCADA          Tabloul electric si de automatizare va prelua datele din statia de clorinare si va comunica prin GPRS (protocol Modbus TCP) cu dispeceratul SCADA de la SA „APA CANAL” LEOVA.</p>	
--	--	--

Utilajul, echipamentul tehnologic: **Statia de dezinfectie containerizata automatizata s. Voinescu (Platforma B)**

	<p>Date transmise in dispeceratul SCADA vor fi, fara a se limita la aceasta lista, urmatoarele:</p> <ul style="list-style-type: none"> <li>- starea de functionare a analizorului de clor si a sistemului de dozare;</li> <li>- parametrii electrici ai statiei de dezinfectie a apei cu hipoclorit de sodiu;</li> <li>- debitul instantaneu si totalizatorul de pe linia de dezinfectie a apei cu hipoclorit de sodiu;</li> <li>- prezenta tensiunii de alimentare;</li> <li>- starea comunicatiei GPRS;</li> <li>- regim statie de dezinfectie a apei cu hipoclorit de sodiu;</li> <li>- cantitate de clor/puls programata;</li> <li>- concentratie de clor programata;</li> <li>- alarma nivel scazut hipoclorit in rezervor;</li> <li>- alarma sisteme de dezinfectie a apei cu hipoclorit de sodiu;</li> <li>- volum de clor dozat;</li> <li>- numar de porniri ale pompei dozatoare de clor;</li> <li>- orele de functionare ale pompei dozatoare de clor;</li> <li>- temperatura apei.</li> </ul>	<p>Date transmise in dispeceratul SCADA vor fi, fara a se limita la aceasta lista, urmatoarele:</p> <ul style="list-style-type: none"> <li>- starea de functionare a analizorului de clor si a sistemului de dozare;</li> <li>- parametrii electrici ai statiei de dezinfectie a apei cu hipoclorit de sodiu;</li> <li>- debitul instantaneu si totalizatorul de pe linia de dezinfectie a apei cu hipoclorit de sodiu;</li> <li>- prezenta tensiunii de alimentare;</li> <li>- starea comunicatiei GPRS;</li> <li>- regim statie de dezinfectie a apei cu hipoclorit de sodiu;</li> <li>- cantitate de clor/puls programata;</li> <li>- concentratie de clor programata;</li> <li>- alarma nivel scazut hipoclorit in rezervor;</li> <li>- alarma sisteme de dezinfectie a apei cu hipoclorit de sodiu;</li> <li>- volum de clor dozat;</li> <li>- numar de porniri ale pompei dozatoare de clor;</li> <li>- orele de functionare ale pompei dozatoare de clor;</li> <li>- temperatura apei.</li> </ul>	
2	<p><b>Specificatii de performanta si conditii privind siguranta in exploatare.</b></p> <ul style="list-style-type: none"> <li>- Respectarea conditiilor de temperatura: -20 + 60°C;</li> <li>- Amplasare: retea distributie apa potabila;</li> <li>- Lichid de lucru: apa potabila;</li> </ul> <p>Montarea se va face conform instructiunilor de montare date de producator.</p>	<p><b>Specificatii de performanta si conditii privind siguranta in exploatare.</b></p> <ul style="list-style-type: none"> <li>- Respectarea conditiilor de temperatura: -20 + 60°C;</li> <li>- Amplasare: retea distributie apa potabila;</li> <li>- Lichid de lucru: apa potabila;</li> </ul> <p>Montarea se va face conform instructiunilor de montare date de producator.</p>	UT4FB CONTROL LTD
3	<p><b>Conditii de garantie si postgarantie</b></p> <p>Min 24 luni garantie de la punerea in functiune.</p> <p>Se vor asigura piese de schimb si service specializat in garantie si post garantie.</p> <p>Piese de schimb in post garantie pe o perioada de 10 ani.</p>	<p><b>Conditii de garantie si postgarantie</b></p> <p>Min 24 luni garantie de la punerea in functiune.</p> <p>Se vor asigura piese de schimb si service specializat in garantie si post garantie.</p> <p>Piese de schimb in post garantie pe o perioada de 10 ani.</p>	UT4FB CONTROL LTD
4	<p><b>Alte conditii tehnice:</b></p> <p>Statia de dezinfectie a apei cu hipoclorit de sodiu va fi insotita de manual de exploatare, fise tehnice ale echipamentelor montate in proces si scheme electrice ale tabloului de automatizare.</p>	<p><b>Alte conditii tehnice:</b></p> <p>Statia de dezinfectie a apei cu hipoclorit de sodiu va fi insotita de manual de exploatare, fise tehnice ale echipamentelor montate in proces si scheme electrice ale tabloului de automatizare.</p>	UT4FB CONTROL LTD

## Measuring instrument - EEM-MA400 - 2901364

Please be informed that the data shown in this PDF Document is generated from our Online Catalog. Please find the complete data in the user's documentation. Our General Terms of Use for Downloads are valid (<http://phoenixcontact.com/download>)



Energy measurement device to measure electrical parameters in low voltage installations up to 500 V, acquisition of total harmonic oscillations - can be extended with RS-485 communication module

### Your advantages

- Can be extended with RS-485 communication module (JBUS/MODBUS)
- Acquisition of total harmonics up to 51st harmonic



### Key Commercial Data

Packing unit	1 pc
GTIN	 4 046356 585804
GTIN	4046356585804
Weight per Piece (excluding packing)	704.200 g
Custom tariff number	90303100
Country of origin	Tunisia
Note	Made to Order (non-returnable)

### Technical data

#### Note

Utilization restriction	EMC: class A product, see manufacturer's declaration in the download area
-------------------------	---

#### Dimensions

Width	96 mm
Height	96 mm
Depth	82 mm
Installation depth with extension module	80 mm
Installation depth without extension module	60 mm

#### Ambient conditions

Ambient temperature (operation)	-10 °C ... 55 °C (14 °F to 131 °F)
---------------------------------	------------------------------------

# Measuring instrument - EEM-MA400 - 2901364

## Technical data

### Ambient conditions

Ambient temperature (storage/transport)	-20 °C ... 85 °C (-4 °F ... 185 °F)
Max. permissible relative humidity (operation)	≤ 95 %
Max. salt spray content	≤ 2.5 %
Degree of protection	IP52 (Front)
	IP30 (Back side)

### Input data

Measuring principle	True r.m.s. value measurement
Acquisition of harmonics	up to 51st harmonic
Measured value	AC sine (50/60 Hz)
Input name	Voltage measuring input V1, V2, V3
Input voltage range	50 V AC ... 500 V AC (Phase/Phase)
	28 V AC ... 289 V AC (Phase/neutral conductor)
Precision	0.2 %
Input name	Current measurement I1, I2, I3
Input current range	via external transformers
Input current	9999 A (primary)
	5 A (secondary)
Current measuring range	0 A ... 9999 A
Overload capacity	6 A (Permanent)
Response threshold from measuring range nominal value	5 mA
Precision	0.2 %
Current overload	10 x I <sub>N</sub> for 1 s
Messbereich_Leistung	0 MW ... 11 MW
	0 Mvar ... 11 Mvar
	0 MVA ... 11 MVA
Precision	0.5 %
Active energy (IEC 62053-22)	Class 0.5 S
Reactive power (IEC 62053-23)	Class 2

### Output data

Output description	Via function module
--------------------	---------------------

### Interfaces

Designation	via communication module
-------------	--------------------------

### General

Display	LCD display, backlighting
Measuring rate	approximately
Supply voltage range	110 V AC ... 400 V AC ±10 %
	120 V DC ... 350 V DC (# 20 %)
Nominal power consumption	5 VA
Power consumption	10 VA (with max. number of extension modules)

# Measuring instrument - EEM-MA400 - 2901364

## Technical data

### General

Mains type	3-phase (3 or 4-wire), 2-phase (2-wire), and single-phase (1-wire)
Color	black
Conformance	CE-compliant
Rated insulation voltage	300 V AC (EN 61010-1)
Test voltage	3.5 kV AC (50 Hz, 1 min.)
	2.2 kV AC (50 Hz, 1 min.)

### UL data

Supply voltage	300 V AC
Nominal supply voltage range	110 V AC ... 240 V AC $\pm 10$ %
	120 V DC ... 250 V DC $\pm 10$ %
Power consumption	10 VA
Operating mode	Indoor use
Surge voltages	Transient overvoltage according to installation classes
Overvoltage category	I, II, III
Overvoltage category of the supply	Min. II
Altitude	$\leq 2000$ m
Ambient temperature (operation)	0 °C ... 40 °C
Max. permissible relative humidity (operation)	80 % (up to 31 °C)
	50 % (at 40 °C)

### Standards and Regulations

Conformance	CE-compliant
UL, USA/Canada	UL 61010-1
	CSA-C22.2 No. 61010-1
	cULus

### Environmental Product Compliance

China RoHS	Environmentally friendly use period: unlimited = EFUP-e
	No hazardous substances above threshold values

### Classifications

#### eCl@ss

eCl@ss 4.0	27210900
eCl@ss 4.1	27210900
eCl@ss 5.0	27210900
eCl@ss 5.1	27210900
eCl@ss 6.0	27142300
eCl@ss 7.0	27142330
eCl@ss 8.0	27142330
eCl@ss 9.0	27142330

# Measuring instrument - EEM-MA400 - 2901364

## Classifications

### ETIM

ETIM 4.0	EC002301
ETIM 5.0	EC002301
ETIM 6.0	EC002301
ETIM 7.0	EC002301

### UNSPSC

UNSPSC 6.01	30211916
UNSPSC 7.0901	39121535
UNSPSC 11	39121535
UNSPSC 12.01	39121535
UNSPSC 13.2	39121535

## Accessories

### Accessories

#### Assembly adapter

DIN rail adapter - EEM-MKT-DRA - 2902078



DIN rail adapter for EEM-MA600 and EEM-MA400 energy meters

---

## Communication module

Communication module - EEM-RS485-MA400 - 2901365



RS-485 JBUS/MODBUS communication module for EEM-MA400

---

## Function module

Special function module - EEM-IMP-MA400 - 2904314



Function module with a pulse or alarm output for the EEM-MA400





## Fisa Tehnica

### INSTALATIE DE CLORINARE CU HIPOCLORIT DE SODIU CU POMPA DOZATOARE

Sistem de dozare Grundfos format din pompa dozatoare digitala de tip DDA, set de instalare cu semnal avertizare de gol pentru monitorizarea nivelului de lichid din rezervor si rezervor.

Pompa dozatoare de tip DDA cu capacitate maxima de 7,5 L/h si presiune de maximum 16 bar

Descriere produs:  
 DDA 7.5-16 FCM-PP/V/C-F-31U2U2FG  
 Cod produs: **97722010**



#### Caracteristici tehnice:

- Debit maxim de dozare: 7.5 l/h
- Debit maxim de dozare in slow mode 50%: 3.75 l/h
- Debit maxim de dozare in slow mode 25%: 1.88 l/h
- Min flow: 2,5 ml/h
- Vascozitate maxima la 100 %: 50 mPas
- Vascozitate maxima in slow mode 50 %: 1800 mPas
- Vascozitate maxima in slow mode 25 %: 2500 mPas
- Aprobari: CE, CSA-US, EAC, RCM
- Tip supapa: Standard
- Acuratetea repetabilitatii: 1 %
- Inaltimea maxima de aspiratie in timpul functionarii: 6 m
- Inaltimea maxima de aspiratie in timpul amorsarii: 2 m
- tensiune de alimentare 230 V  $\pm$  10%, 50/60 Hz;
- raport dozare: 1:3000 -> domeniu capacitate de dozare 0,0025 ... 7,5 L/h,
- contrapresiune max. 16 bar;
- clasa de protectie: IP 65
- volum cursa de dozare: 0,74 mL
- frecventa curse de dozare : maximum 190 curse/minut
- racorduri: furtun ( $\varnothing_{ext}$  x  $\varnothing_{int}$ ): 6 x 4, 9 x 6, 12 x 6, 12 x 9 mm (sunt incluse toate);
- ajustare manuala sau automata a capacitatii de dozare;
- posibilitate de control extern prin contacte libere de potential; control cu microprocesor si posibilitate de multiplicare/demultiplicare numar de impulsuri de la contorul de apa, iesiri/intrari semnal analog 4...20 mA, intrari/iesiri de releu, intrare stop extern, intrare semnal de gol;
- dezaerare atat in timpul functionarii cat si in perioadele de repaus dintre ciclurile de functionare;
- sistem de control al debitului cu diagnoza selectiva a cauzei (suprapresiune, linie de refulare crapata, cavitatie, scurgeri de lichid pe la supape);
- monitorizare (contra)presiune prin senzorul de presiune integrat;

- masurarea capacitatii de dozare prin detectarea deviatii debitului de dozare fixat si compensarea acestora prin corectia frecventei curselor de dozare (eliminarea anomaliilor date de prezenta unor bule de gaz sau o contrapresiune scazuta)
- materiale componente: PP – cap de dozare, Viton – elastomer, Ceramic – bila supapei de dozare;
- afisaj iluminat cu cristale lichide in culori pentru afisarea starilor de operare, alarmelor si mesajelor de avertizare;
- placa pentru instalarea pompei fie pe rezervorul de lichid, fie pe perete;
- in functie de pozitia de instalare, cubul de control al pompei poate fi (re)aranjat in 3 pozitii: fata, stanga sau dreapta, fara oprirea procesului de dozare;
- meniul pompei usor de utilizat si disponibil in peste 20 de limbi, inclusiv limba romana.

Dimensiuni:

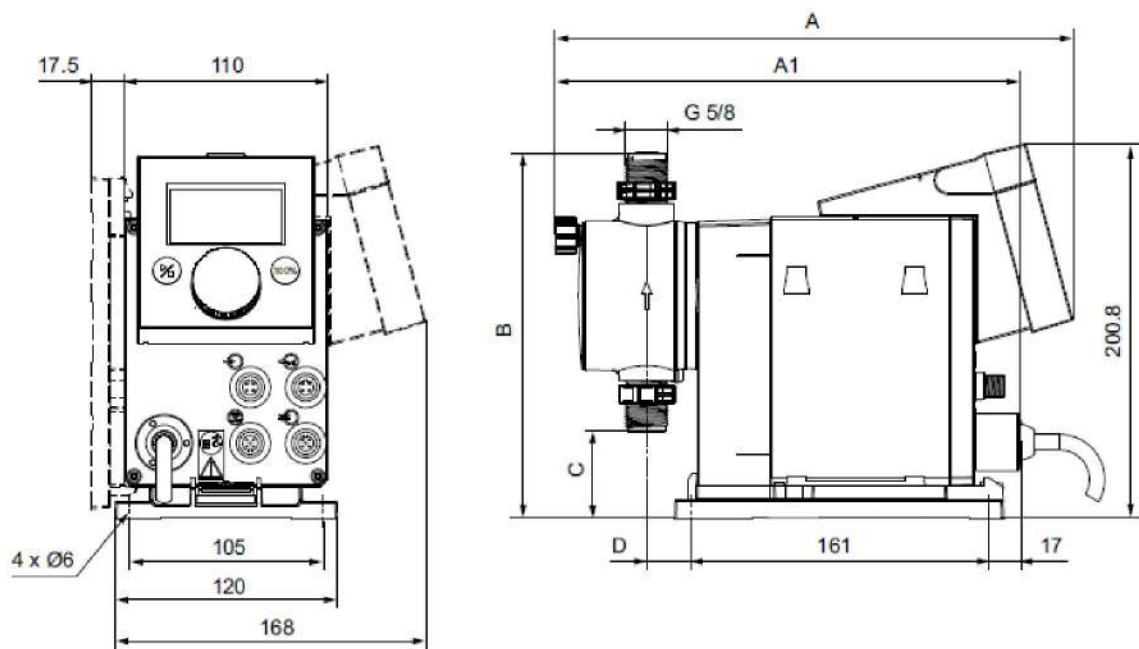

Tip pompa	A (mm)	A1 (mm)	B (mm)	C (mm)	D (mm)
DDA 7,5-16	280	251	196	46,5	24

Rezervor de stocare solutie de hipoclorit de sodiu

Descriere produs: Tank PE-transp  
Cod produs: in functie de volum



Caracteristici tehnice:

- Volum: in functie de capacitatea sistemului de dozare
- Material: PE
- Culoare material: transparent
- Tip constructiv: rotund

Dimensiuni (mm):

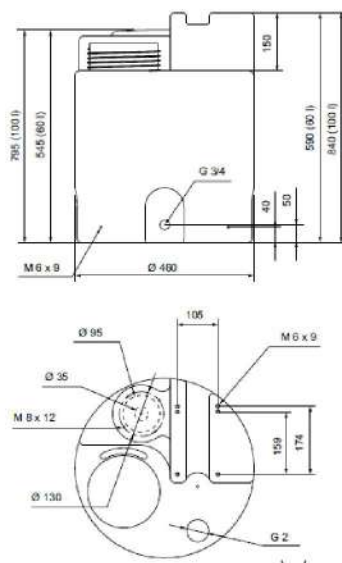

Fig. 50 Cylindrical tank, 60 and 100 litres

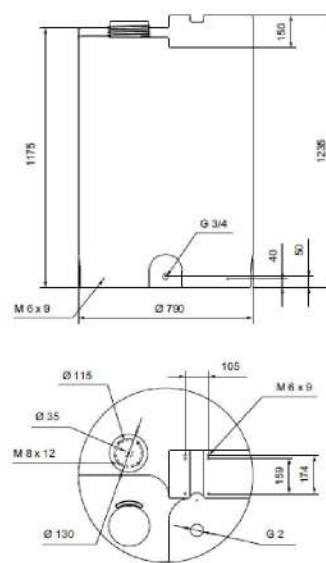

Fig. 52 Cylindrical tank, 500 litres

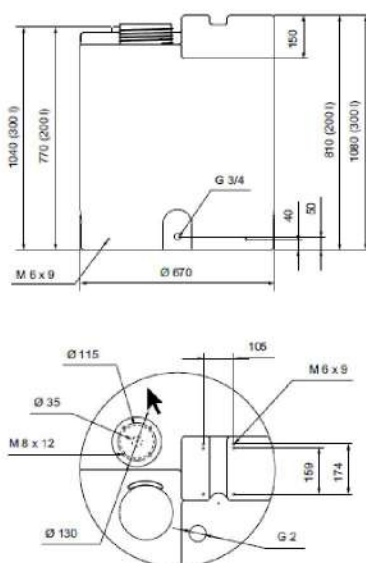

Fig. 51 Cylindrical tank, 200 and 300 litres

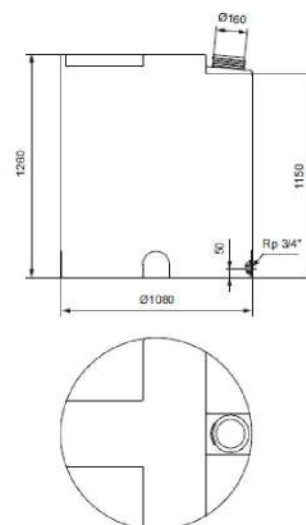

Fig. 53 Cylindrical tank, 1000 litres

Linie de aspiratie rigida

Descriere produs:  
 RSL-0690-2L-G5/8 PE/V,E/C U2  
 Cod produs: **in functie de rezervorul de hipoclorit**



Componenta si caracteristici tehnice:

- clapet de sens unic
- racorduri furtun ( $\varnothing_{ext} \times \varnothing_{int}$ ): 6 x 4, 9 x 6, 12 x 6, 12 x 9 mm (sunt incluse toate)
- 2 contacte de tip Reed pentru 2 semnale avertizare de gol
- 5 m cablu incastat in teava PE
- stecher rotund de tip M12
- Diametru nominal: DN8
- material: PE
- elastomer: EPDM/FKM

Dimensiuni (mm):

Tip rezervor	Capacitate rezervor (L)	Adancime imersie recomandata (mm)
Cilindric/rotund	60	500
	100	690
	200	690
	300	980
	500	1100
	1000	1200

Agitator manual

Descriere produs:  
Handmixer  
Cod produs: **98133793**



Componenta si caracteristici tehnice:

- lungime maxima: 1200 mm, dar lungimea poate fi ajustata in functie de volumul/tipul rezervorului de stocare hipoclorit
- Diametru nominal: DN 15
- material: PE

Supapa multifunctionala

Descriere produs:  
MFV-G5/8-16 PVC/V U2  
Cod produs: **95730823**



Caracteristici tehnice:

- Presiune maxima: 16 bar
- Diametru nominal: DN 15
- Racorduri furtun ( $\varnothing_{\text{ext}} \times \varnothing_{\text{int}}$ ): 6 x 4, 9 x 6, 12 x 6, 12 x 9 mm (sunt incluse toate)
- material:
  - carcasa: PVDF
  - racorduri: PVC
  - elastomer: FKM/Viton

Dimensiuni (mm):

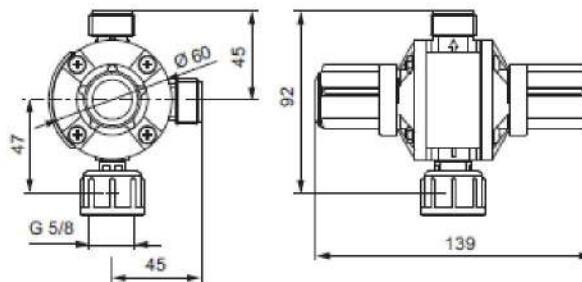

Furtun dozare

Descriere produs:  
hose PE-4/6-10m 3/U2  
Cod produs: **91836504**



Caracteristici tehnice:

- material: PE
- presiune maxima: 13 bar (la 20 °C)
- dimensiuni:  $\varnothing_{\text{ext}} \times \varnothing_{\text{int}}$  : 6 x 4 mm
- lungime: 10 m

## Unitate de injectie

Descriere produs:  
Injection unit 0203-16 PVC/V/C 4U2-2  
Cod produs: **95730964**

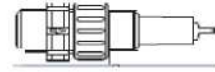

## Caracteristici tehnice:

- material:
  - o carcasa: PVC
  - o elastomer: FKM/Viton
  - o bila supapa: Ceramic
- presiune maxima: 16 bar

## Dimensiuni:

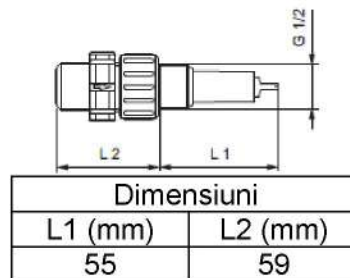



## Sistem de masura a concentratiei de clor rezidual in apa tratata

Descriere produs:  
**DID-1 BF1-FCL2**  
 Cod produs: **98915656**



### Date tehnice:

- Alimentare 220V
- Sistem preasamblat al controlerului si a celulei de masura (instalare pe perete)
- masura si control on-line a concentratiei de clor rezidual, cu compensarea autoamata a temperaturii
- sistem de prelevare proba de apa pentru analiza concentratiei de clor rezidual
- Senzor precalibrat de clor de tip amperometric în constructie metalica, format din 3 electrozi:
  1. electrod de aur (de masura) acoperit acoperit de o membrana hidrofilica permeabila speciilor ionice in general, ,
  2. electrod de referinta (Ag/halogenura de Ag)
  3. contraelectrod (inox)
- gama de masura clor rezidual 0-2mg/l
- senzor de temperatura a apei
- presiune maxima de lucru 3 bar

### Dimensiuni (mm):

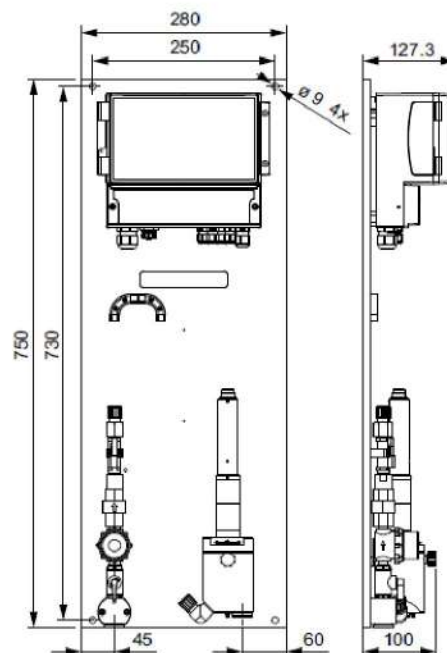

## Controller - ILC 151 GSM/GPRS - 2700977

Rețineți că datele furnizate aici sunt luate din catalogul online. Pentru informații și date complete, consultați documentația de utilizare. În cazul descărcărilor de pe internet se aplică Termenii și condițiile de utilizare generale.  
(<http://download.phoenixcontact.de>)



Inline Controller with Ethernet interface and GSM modem for coupling to other controllers and systems, with programming options according to IEC 61131-3, complete with plug and labeling field.

### Descriere articol

The ILC 151 GSM/GPRS combines the options of class 100 controllers with wireless communication via mobile phone networks. A GSM/GPRS modem is integrated in the controller. This enables SMS messages to be sent and received and supports packet-oriented (IP) communication via GPRS.

The controller itself offers 16 digital inputs and 4 digital outputs for various control tasks. The 512 kB program memory and 512 kB data memory complete the functions of the controller, thereby providing plenty of space to accommodate larger applications as well.

The Inline controller (ILC) range covers a wide performance range. From entry-level versions to high-end controllers, users can choose the right controller for their application.

### Caracteristici articol

- Numerous protocols supported such as: HTTP, FTP, SNMP, SMTP, SQL, MySQL, etc.
- Free engineering with PC Worx Express (IEC 61131-3)
- Complete INTERBUS master (4096 I/O points)
- Integrated web server for visualization with WebVisit
- FTP server
- Flash file system



### Date comerciale

Unitate de ambalare	1 buc
GTIN	 4 046356 665537
Greutate pe bucată (fără ambalaj)	350.0 g
Cod tarif vamal	85371091
#ara de origine	Germany

### Date tehnice

#### Note

Utilization restriction	EMC: class A product, see manufacturer's declaration in the download area
-------------------------	---

# Controller - ILC 151 GSM/GPRS - 2700977

## Date tehnice

### Dimensions

Width	85 mm
Height	119.8 mm
Depth	71.5 mm

### Ambient conditions

Degree of protection	IP20
Ambient temperature (operation)	-25 °C ... 55 °C
Ambient temperature (storage/transport)	-25 °C ... 85 °C
Permissible humidity (operation)	10 % ... 95 % (according to DIN EN 61131-2)
Permissible humidity (storage/transport)	10 % ... 95 % (according to DIN EN 61131-2)
Air pressure (operation)	70 kPa ... 106 kPa (up to 3000 m above mean sea level)
Air pressure (storage/transport)	70 kPa ... 106 kPa (up to 3000 m above mean sea level)
Shock	25g, Criterion 1, according to IEC 60068-2-27
Vibration (operation)	5g

### Control system

Programming tool	PC WORX / PC WORX EXPRESS
Diagnostics tool	DIAG+
Configuration tool	Config+ Version 1.01 or later

### Mechanical design

Weight	285 g
Diagnostics display	No
Controller redundancy	No

### Data interfaces

Interface	INTERBUS local bus (master)
Connection method	Inline data jumper
Transmission speed	500 kBaud / 2 MBaud umschaltbar
Interface	Ethernet 10Base-T/100Base-TX
Connection method	RJ45 socket
Transmission speed	10/100 MBit/s
Interface	GSM / GPRS
Connection method	SIM card, SMA antenna connection

### Power supply

Typical current consumption	210 mA
Max. current consumption	860 mA (360 mA communications power + 500 mA analog voltage supply)
Supply voltage	24 V DC
Supply voltage range	19.2 V DC ... 30 V DC
Residual ripple	± 5 %
Power dissipation	max. 5 W

## Controller - ILC 151 GSM/GPRS - 2700977

### Date tehnice

#### Fieldbus function

Amount of process data	max. 4096 Bit (INTERBUS)
Number of supported devices	max. 128
Number of local bus devices that can be connected	max. 63 (observe current consumption)
Number of devices with parameter channel	max. 16
Number of supported branch terminals with remote bus branch	max. 3

#### Direct I/Os

Input name	Digital inputs
Number of inputs	16
Connection method	Inline potential distributor
Description of the input	EN 61131-2 type 1 NPN/PNP
Output name	Digital outputs
Number of outputs	4
Connection method	2, 3, 4-wire
Maximum output current per channel	500 mA
Without analog input	yes
Without analog output	yes
Without pulse direction output	yes
Without counter input	yes

#### IEC 61131 runtime system

Programming tool	PC WORX / PC WORX EXPRESS
Program memory	512 kByte (43 K instructions (IL))
Mass storage	512 kByte
Retentive mass storage	48 kByte (NVRAM)
Number of control tasks	8
Realtime clock	Yes

#### General data

Processor	Altera Nios II 64 MHz
Diagnostics display	No

### Clasificări

#### eCl@ss

eCl@ss 4.0	27240490
eCl@ss 4.1	27240490
eCl@ss 5.0	27242208
eCl@ss 5.1	27242208
eCl@ss 6.0	27242208
eCl@ss 7.0	27242208
eCl@ss 8.0	27242207

## Controller - ILC 151 GSM/GPRS - 2700977

### Clasificări

#### ETIM

ETIM 3.0	EC001423
ETIM 4.0	EC000236
ETIM 5.0	EC000236

#### UNSPSC

UNSPSC 6.01	43172015
UNSPSC 7.0901	43201404
UNSPSC 11	43172018
UNSPSC 12.01	43201404
UNSPSC 13.2	43201404

**Qty. Description**

1 DDA 7.5-16



Note! Product picture may differ from actual product

Product No.: [97722010](#)

DDA 7.5-16 FCM-PP/V/C-F-31U2U2

The SMART Digital DDA is a compact positive displacement, diaphragm dosing pump with variable-speed drive (stepper motor) and intelligent control electronics with minimum energy consumption. The SMART Digital Dosing series operates at full stroke length to ensure optimum accuracy, priming and suction, even for high-viscosity or degassing liquids. The duration of each discharge stroke varies according to the capacity set, resulting in optimum smooth and continuous discharge flow.

The click-stop mounting plate allows installation in three different positions without using any additional accessories. The control cube can be turned easily into front, left or right position. The click wheel and the multi-coloured backlit graphical, plain-text LC display make commissioning and operation intuitive. The control elements are protected by a transparent cover.

The sensor-based FlowControl (FC) system detects malfunctions directly in the dosing head and displays them in plain text in the alarm menu, e.g. air bubbles, line burst, overpressure. The integrated flow measurement function (only FCM) measures the actual flow and makes additional monitoring and control equipment redundant (accuracy of  $\pm 1,5\%$  of set value in case of trouble-free process). The measured flow is displayed and can be integrated in the process control, e.g. SCADA. Furthermore, the AutoFlowAdapt function (only FCM) automatically adjusts the pump speed according to the process conditions to maintain target flow even at e.g. varying backpressure or air bubbles foaming (degassing drive strategy).

The dosing head is composed of:

- Long lifetime and universal, chemically resistant full-PTFE diaphragm.
- Double ball valves for highest dosing accuracy.
- Deaeration valve for easy start-up.
- Pressure sensor.

Operation modes:

- Manual dosing in ml/h, l/h or gph.
- Pulse control in ml/pulse (incl. memory function).
- Analog control 0/4-20 mA (scalable).
- Pulse-based batch function in ml, l or gal.
- Timer-based batch function (Dosing timer, cycle or week).
- Fieldbus control (Genibus prepared for ProfibusDP E-box).

Other features:

- Auto deaeration during pump standby to avoid breakdowns due to air-locking.
- Two SlowMode steps (anti-cavitation), 50 % (maximum flow: 3.75 l/h) and 25 % (maximum flow: 1.88 l/h), e.g. for high-viscosity or degassing liquids.
- Service information display to show when service and which wear-part order number is required.
- Two-step key lock function to protect the pump against unauthorised access.
- Additional display function to provide further information, e.g. the actual mA input signal.
- Counter for total dosed volume (resettable), operating hours, etc.
- Save and load customised settings as well as reload of factory settings.

Signal inputs/outputs:

Qty.	Description
	<ul style="list-style-type: none"> <li>- Input for pulse, analog 0/4-20mA, external stop.</li> <li>- Input for low-level and empty-tank signal.</li> <li>- Two potential-free output relays for max. 30 V AC/DC (configurable, e.g. alarm, stroke signal, pump dosing, timer etc.)</li> <li>- Output analog 0/4-20mA.</li> <li>- Fieldbus communication interface (GeniBus, also for additional Profibus DP E-box to retrofit).</li> </ul> <p><b>Technical:</b></p> <p>Type key: DDA 7.5-16 FCM-PP/V/C-F-31U2U2</p> <p>Max. Flow: 7.5 l/h</p> <p>Max. flow in slow mode 50%: 3.75 l/h</p> <p>Max. flow in slow mode 25%: 1.88 l/h</p> <p>Min flow: 2.5 ml/h</p> <p>Turn-down ratio: 1:3000</p> <p>Approvals on nameplate: CE, CSA-US, EAC, RCM</p> <p>Valve type: Standard</p> <p>Maximum viscosity at 100 %: 50 mPas</p> <p>Maximum viscosity in slow mode 50 %: 1800 mPas</p> <p>Maximum viscosity in slow mode 25 %: 2500 mPas</p> <p>Accuracy of repeatability: 1 %</p> <p><b>Materials:</b></p> <p>Dosing head: PP (Polypropylene)</p> <p>Valve ball: Ceramic</p> <p>Gasket: FKM</p> <p><b>Installation:</b></p> <p>Range of ambient temperature: 0 .. 45 °C</p> <p>Maximum operating pressure: 16 bar</p> <p>Installation set: NO</p> <p>Installation type: No installation set</p> <p>Pump inlet: 4/6, 6/9, 6/12, 9/12 mm</p> <p>Pump outlet: 4/6, 6/9, 6/12, 9/12 mm</p> <p>Max. Suction lift during operation: 6 m</p> <p>Max. Suction lift during priming: 2 m</p> <p><b>Liquid:</b></p> <p>Pumped liquid: Water</p> <p>Liquid temperature range: -10 .. 45 °C</p> <p>Selected liquid temperature: 20 °C</p> <p>Density: 998.2 kg/m<sup>3</sup></p> <p><b>Electrical data:</b></p> <p>Maximum power input - P1: 24 W</p> <p>Mains frequency: 50 / 60 Hz</p> <p>Rated voltage: 1 x 100-240 V</p> <p>Enclosure class (IEC 34-5): IP65 / NEMA 4X</p> <p>Length of cable: 1.5 m</p> <p>Type of cable plug: EU</p> <p>Inrush current: 25A at 230V for 2ms</p> <p><b>Controls:</b></p> <p>Control variant: FCM</p> <p>Level control: YES</p> <p>Analog input: 0/4-20 MA</p> <p>Pulse control: YES</p> <p>Ext. Stop input: YES</p> <p>Analog output: 0/4-20 MA</p> <p>Output relays: 2</p>

Qty.	Description
	Bus communication: YES
	<b>Others:</b>
	Net weight: 2 kg
	Gross weight: 3 kg
	Color: RED



# DID

**Compact measuring systems, controllers, sensors and accessories**  
up to 3 parameters (Cl<sub>2</sub>, ClO<sub>2</sub>, H<sub>2</sub>O<sub>2</sub>, PAA, pH, ORP, conductivity)

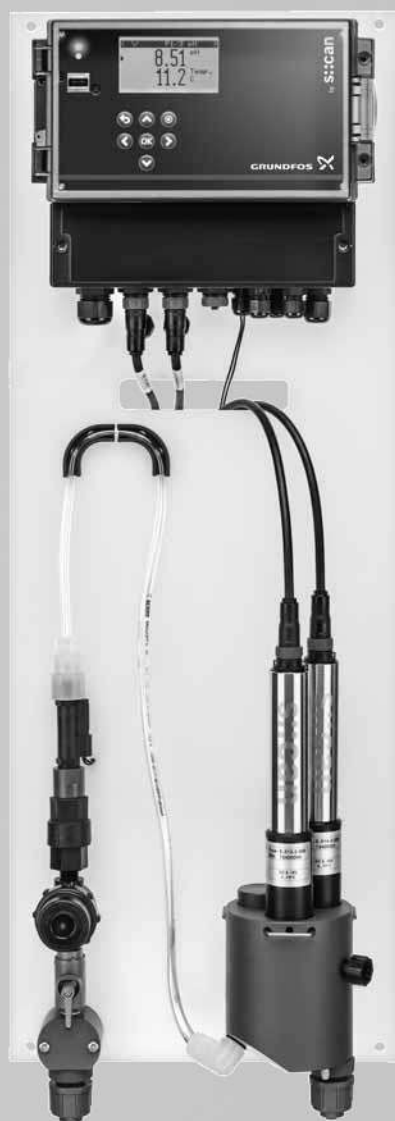

<b>1. Product introduction</b>	<b>3</b>
General	3
Characteristics and main features	3
CU 382 control unit	3
Sensors	3
Pre-assembled measuring system.	3
<b>2. Type key</b>	<b>4</b>
<b>3. Functions</b>	<b>5</b>
Components	5
Operating elements	6
CU 382 control unit	6
Software menu	7
<b>4. Installation schemes</b>	<b>8</b>
<b>5. Technical data</b>	<b>9</b>
CU 382-1 and CU 382-3 control unit	9
Sensors for disinfectants	10
Sensors for pH, ORP and conductivity	11
Hydraulic installation	11
Weights	12
<b>6. Dimensions</b>	<b>13</b>
DID with flow cell BF1	13
DID with flow cell BF3	13
DID for wall mounting and sensor with holder	14
<b>7. Product selection</b>	<b>15</b>
Standard range DID pre-assembled system	15
<b>8. Accessories and maintenance kits</b>	<b>16</b>
Accessories	16
Maintenance kits	18
<b>9. Grundfos Product Center</b>	<b>19</b>

# 1. Product introduction

## General

Monitoring of typical water quality parameters as well as precise control of disinfectant addition or pH adjustment is essential for many water treatment processes. Bus interface as well as data logging functionalities and intuitive user interface are a must for M&C today.

The new Grundfos by s::can DID systems are the perfect combination of s::can's state-of-the-art digital sensor technology and Grundfos' experience in PID controlling of dosing and disinfection processes. DID systems are designed to match perfectly with Grundfos dosing pumps, gas dosing systems as well as systems for the generation and dosing of chlorine dioxide and hypochlorite.

## Characteristics and main features

DID systems are available as pre-assembled systems with bypass flow cell or as kits for applications with tank-immersed sensors.

Variants with bypass flow cell are intended for monitoring and control of disinfectants, pH, ORP, conductivity and temperature. The water flow through the cell is kept at an appropriate level by a flow restrictor. Lack of water is detected by a flow switch and leads to an alarm. A shut-off ball valve and a sampling cock complete the hydraulic installation, which is compatible with Grundfos standard hoses.

System configurations for tank immersion are available with up to 2 sensors for pH, ORP and conductivity, and always include temperature measurement. These variants allow measurement of water parameters directly in the tank or basin without the need for a bypass line and flow cell. The control unit can either be fixed directly at a wall or back plate, or mounted on a DIN rail in a cabinet.

## CU 382 control unit

- Intuitive plain-text operation
- Data logger functionality
- Up to 3 controller outputs, freely assignable
- Modbus included
- Modbus sensor interface
- Data interchange with USB stick
- Wide-range power supply

## Sensors

- Modbus interface to CU 382 control unit
- Onboard storage of calibration data
- Temperature compensation included for all sensors
- Long service intervals
- Pre-calibrated (pH, ORP, conductivity sensor)
- 1-2 sensor variants per parameter for all applications and measuring ranges
- Diaphragm-covered amperometric sensor principle for disinfectant sensors
- Low pH dependency for free-chlorine sensors

## Pre-assembled measuring system

- Automatic setting of the water flow and detection of missing water flow in systems with flow cell
- Sensor holder included in systems for tank installation
- 7.5 m of cable included in systems for tank installation (extension cables are available in lengths up to 20 m)
- Sensor guard included in systems for tank installation

## 2. Type key

Example: DID-3 BF3-FCL2/TCL2/pH

	Code	Description
CU 382 control unit variant	DID-1	CU 382-1 for 1 parameter + temperature, 100-250 VAC, 50-60 Hz
	DID-3	CU 382-3 for 3 parameters + temperature, 100-250 VAC, 50-60 Hz
Installation variant	BF1	Bypass flow cell, 1 sensor
	BF3	Bypass flow cell, 3 sensors
	TI1	Tank immersion, 1 sensor
	TI2	Tank immersion, 2 sensors
Parameters/sensors	FCL2	Free chlorine, 0-2 ppm
	FCL20	Free chlorine, 0-20 ppm
	TCL2	Total chlorine, 0-2 ppm
	TCL20	Total chlorine, 0-20 ppm
	CDI2	Chlorine dioxide, 0-2 ppm
	CDI20	Chlorine dioxide, 0-20 ppm
	HP2	Hydrogen peroxide, 0-200 ppm
	HP20	Hydrogen peroxide, 0-2000 ppm
	PA2	Peracetic acid, 0-200 ppm
	PA20	Peracetic acid, 0-2000 ppm
	pH	pH 2-12, up to 10 bar, 70 °C
	ORP	ORP, -2000 mV to +2000 mV, up to 10 bar, 70 °C
	CND	Conductivity, 1-500000 µS/cm (2-42 PSU), up to 20 bar, 70 °C

### Remarks:

- All sensors include temperature measurement
- Measurement of disinfectant parameters (FCL, TCL, CDI, HP or PA) is only possible with BF1 or BF3 installation variant
- BF1 and BF3 installation variants include flow detection
- BF1 and BF3 installation variants include 1.0 m sensor cable(s)
- TI1 and TI2 installation variants are only possible for parameters pH, ORP or CND
- TI1 and TI2 installation variants include 7.5 m sensor cable(s)
- Mains cable is not included, please select from accessories list and order separately

### 3. Functions

#### Components

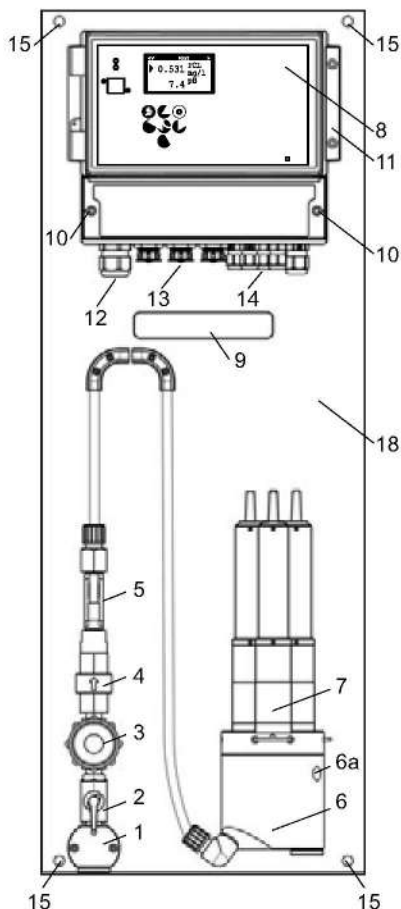

TM06 5665 5115

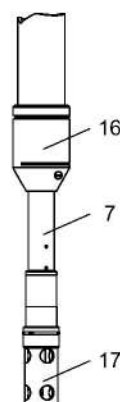
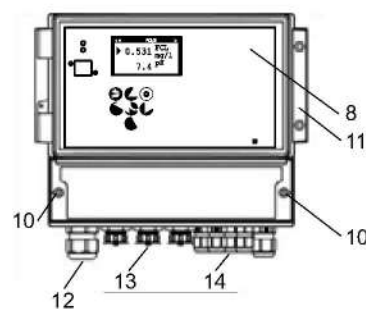

TM06 5978 0316

**Fig. 1** Components of DID with flow cell

**Fig. 2** Components of DID with immersed sensor





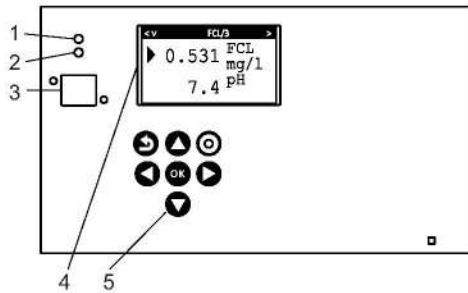

Pos.	Description
1	Water inlet, G 1/2" internal thread and connections for Grundfos hoses
2	Ball valve, 1/4" NPT
3	Inlet strainer, with screw cap for removal and cleaning of the sieve
4	Flow restrictor, mechanical
5	Flow detector, digital. Sends an alarm to the CU 382 control unit, if the water flow falls below the minimal flow rate (approx. 0.25 l/min).
6	Flow cell for 1 or 3 sensors. Includes an outlet with G 1/2" internal thread and connections for Grundfos hoses, and a sampling valve (6a).
7	Sensors
8	CU 382 control unit for 1 or 3 sensors
9	Opening in the back plate for the power supply cables and sensor cables
10	Screw joints to open the cable terminal compartment
11	Clip to open the housing cover
12	Cable gland for power supply
13	Connector for s::can sensors
14	Cable gland for signal outputs
15	Holes for wall-mounting
16	Sensor holder
17	Sensor guard
18	Back plate

## Operating elements



TM06 5634 5115

Fig. 3 Operating elements

Pos.	Description
1	Power LED, green
2	Communication LED, orange <ul style="list-style-type: none"> <li>Flashes during communication with a sensor</li> </ul>
3	USB slot <ul style="list-style-type: none"> <li>For data export or firmware update</li> </ul>
4	Display
Operating buttons	
	 [Back] button <ul style="list-style-type: none"> <li>Exits the current menu</li> </ul>
	 [Up] button <ul style="list-style-type: none"> <li>Moves the marker to the line above <ul style="list-style-type: none"> <li>The first character of the selected line is a triangle</li> </ul> </li> <li>Increases values</li> </ul>
	 [Function] button <ul style="list-style-type: none"> <li>Enters the setup menus</li> <li>Disables or deletes values</li> </ul>
5	 [Left] button <ul style="list-style-type: none"> <li>Moves the marker to the left</li> </ul>
	 [Ok] button <ul style="list-style-type: none"> <li>Enters the selected menu</li> <li>Confirms the selected line or value</li> <li>Acknowledges alarms</li> </ul>
	 [Right] button <ul style="list-style-type: none"> <li>Moves the marker to the right</li> </ul>
	 [Down] button <ul style="list-style-type: none"> <li>Moves the marker to the line below <ul style="list-style-type: none"> <li>The first character of the selected line is a triangle</li> </ul> </li> <li>Decreases values</li> </ul>

## CU 382 control unit







TM06 5969 0316

Fig. 4 CU 382 control unit

## Overview of features

Features	CU 382-1	CU 382-3
1 connector for digital s::can sensor	•	
3 connectors for digital s::can sensors		•
3 PID controllers	•	•
2 digital relay outputs, adjustable as controller outputs and/or limit switch outputs	•	•
3 analog outputs, adjustable as controller outputs and/or measured value outputs	•	•
1 alarm relay output	•	•
1 cleaning valve output	•	•
2 digital inputs, adjustable as remote on/off input, water meter pulse input or setpoint switch input	•	•
1 analog input, adjustable as flow meter input or external setpoint input	•	•
Data logger functionality (measured values, logfile, configuration)	•	•
USB host interface	•	•
Multilingual user interface	•	•
Modbus (via RS485)	•	•
1 input for flow switch of flow cell	•	•

## Software menu

Status	Parameter	Controller	Alarm																																										
<table border="1"> <thead> <tr> <th colspan="2">Status &gt;</th> </tr> </thead> <tbody> <tr> <td>Version</td> <td>V7.05B1</td> </tr> <tr> <td>Serial:</td> <td>9999999</td> </tr> <tr> <td>Waiting:</td> <td>1s</td> </tr> <tr> <td>YYYY/MM/DD</td> <td>h/min/sec</td> </tr> </tbody> </table>	Status >		Version	V7.05B1	Serial:	9999999	Waiting:	1s	YYYY/MM/DD	h/min/sec	<table border="1"> <thead> <tr> <th>&lt; V</th> <th>P1/3 pH</th> <th>&gt;</th> </tr> </thead> <tbody> <tr> <td>▶</td> <td>9.49</td> <td>pH</td> </tr> <tr> <td></td> <td>22.1</td> <td>Temp. C</td> </tr> </tbody> </table>	< V	P1/3 pH	>	▶	9.49	pH		22.1	Temp. C	<table border="1"> <thead> <tr> <th>&lt; V</th> <th>C2/2</th> <th>&gt;</th> </tr> </thead> <tbody> <tr> <td></td> <td>15 %</td> <td></td> </tr> <tr> <td>Type</td> <td colspan="2">PID/Running</td> </tr> <tr> <td>pH</td> <td colspan="2">&gt;4/20 mA #2</td> </tr> <tr> <td></td> <td colspan="2">AV/SP: 6.86/7.00 (ext.)</td> </tr> </tbody> </table>	< V	C2/2	>		15 %		Type	PID/Running		pH	>4/20 mA #2			AV/SP: 6.86/7.00 (ext.)		<table border="1"> <thead> <tr> <th>&lt;</th> <th>AP001 A1/1</th> </tr> </thead> <tbody> <tr> <td></td> <td>YYYY/MM/DD</td> </tr> <tr> <td></td> <td>Follow below</td> </tr> <tr> <td></td> <td>Lower alarm limit</td> </tr> </tbody> </table>	<	AP001 A1/1		YYYY/MM/DD		Follow below		Lower alarm limit
Status >																																													
Version	V7.05B1																																												
Serial:	9999999																																												
Waiting:	1s																																												
YYYY/MM/DD	h/min/sec																																												
< V	P1/3 pH	>																																											
▶	9.49	pH																																											
	22.1	Temp. C																																											
< V	C2/2	>																																											
	15 %																																												
Type	PID/Running																																												
pH	>4/20 mA #2																																												
	AV/SP: 6.86/7.00 (ext.)																																												
<	AP001 A1/1																																												
	YYYY/MM/DD																																												
	Follow below																																												
	Lower alarm limit																																												
																																													
<b>General setup</b>	<b>Parameter setup</b>	<b>Controller setup</b>	<b>Alarm setup</b>																																										
<ul style="list-style-type: none"> <li>▶ Manage sensor</li> <li>Manage parameters</li> <li>Cleaning 1</li> <li>Measuring settings</li> <li>Date/Time</li> <li>Modbus slave</li> <li>Update software</li> <li>Select language</li> <li>Service</li> </ul>	<ul style="list-style-type: none"> <li>▶ Calibrate expert</li> <li>Monitor</li> <li>Display settings</li> <li>Alarm settings</li> <li>Output</li> <li>Output settings</li> <li>pH compensation</li> <li>Parameter info</li> <li>Remove parameter</li> </ul>	<ul style="list-style-type: none"> <li>▶ Setpoint</li> <li>Settings PID/2-P/None</li> <li>Source</li> <li>Output DI/mA</li> <li>Output settings</li> <li>Alarm settings</li> <li>Reset state</li> </ul>	<ul style="list-style-type: none"> <li>▶ Acknowledgment of alarms</li> </ul>																																										
<b>USB Data transfer</b>																																													
	<ul style="list-style-type: none"> <li>▶ Copy results</li> <li>Delete results</li> <li>Copy logfile</li> <li>Delete logs</li> <li>Update software...</li> </ul>																																												

## 4. Installation schemes

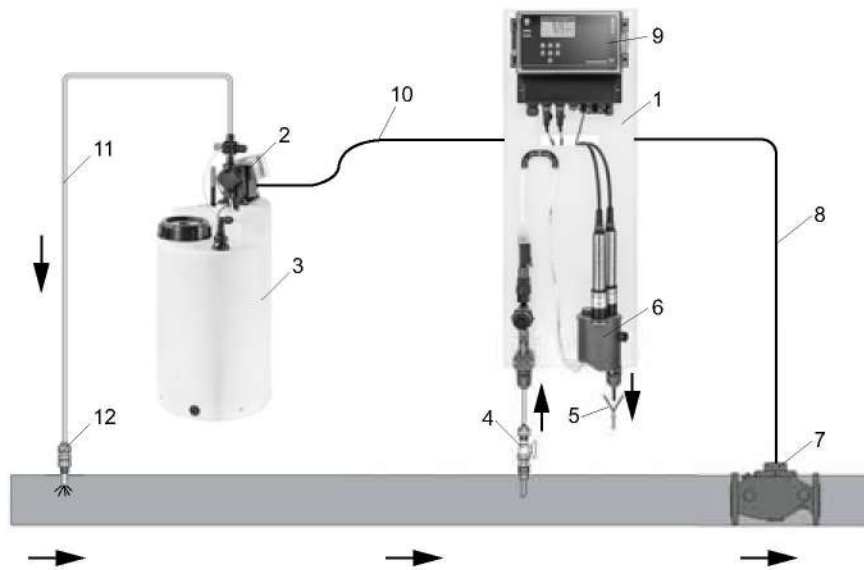

Fig. 5 Installation scheme of DID with bypass flow cell

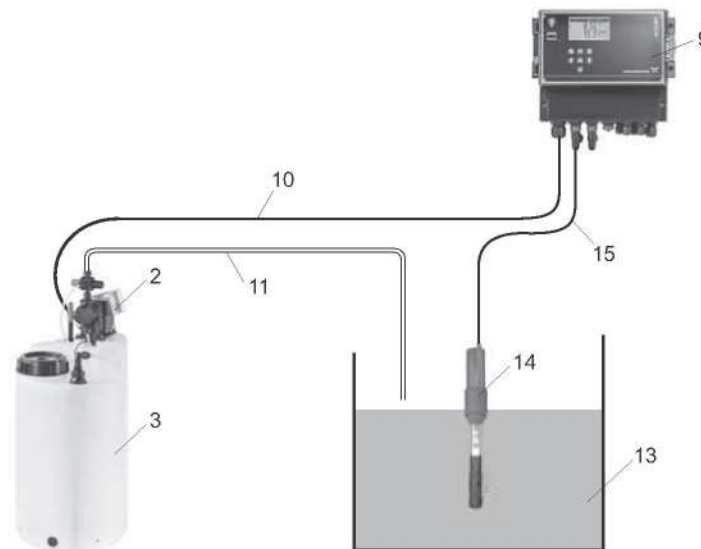

Fig. 6 Installation scheme of DID for tank immersion

### Legend

1	DID with bypass flow cell
2	SMART Digital dosing pump
3	Dosing tank
4	Sample water extraction
5	Sample water outlet to the drain
6	Bypass flow cell for 1 or 3 sensors
7	Flowmeter
8	Signal cable from flowmeter to CU 382 control unit
9	CU 382 control unit
10	Control cable to SMART Digital dosing pump
11	Dosing line
12	Injection unit
13	Tank
14	Sensor holder
15	Signal cable from sensor to CU 382 control unit

TM06 5635 5115

TM06 6082 0616



## 5. Technical data

### CU 382-1 and CU 382-3 control unit

Data		CU 382-1	CU 382-3	
General data	Number of sensor connectors (Buccaneer 400 series)	1	3	
	Number of analog inputs (4-2000 mA)		1	
	Number of digital inputs		2	
	Number of analog outputs (4-20 mA)		3	
	Number of digital outputs NO relays		2	
	Number of digital outputs NO/NC relays (alarm relays)		1	
	Number of USB ports (host)		1	
	Number of RS485 ports (Modbus slave)		1	
	Number of M20 cable gland entries (mains)		1	
	Number of M16 cable gland entries		1	
	Number of M12 cable gland entries		4 <sup>1)</sup>	
	Memory (industrial grade SLC)	[MB]		512
	Ambient temperature	[°C]		-20 to +45
Electrical data <sup>2)</sup>	Humidity (non condensing)	[%]	5 to 90	
	Voltage	[V]	100-240	
	Frequency	[Hz]	50-60	
	Power consumption	[W]	33	
	Max. inrush current	[A]	< 30	
Enclosure class			IP65	
Signal input, analog 4-20 mA	Input resistance	[Ohm]	100	
	Galvanic isolation (to system ground/earth)	[kV]	1	
	Resolution	[bit]	12	
Signal input, digital	Standard setup (for connection with mechanical relay/switch)			
	• Max. input frequency	[Hz]	100	
	• Low input voltage	[V]	< 7	
	• High input voltage	[V]	> 8	
	• Input resistance	[Ohm]	> 1000	
	Optional setup (for connection with external voltage output)			
	• Max. input frequency	[Hz]	100	
	• Low input	[Ohm]	< 100	
	• High input	[Ohm]	> 2000	
	• Galvanic isolation (to system ground/earth)	[kV]	1	
Signal output, analog 4-20 mA	Maximum load resistance	[Ohm]	500	
	Galvanic isolation (to system ground/earth)	[kV]	1	
	Resolution	[bit]	12	
Signal output, digital with relays <sup>3)</sup>	Maximum working voltage	[VAC]	250	
	Maximum switchable load	[A]	6	
	Maximum load	[VA]	600	
Weight		[kg]	1.3	
Approvals			CE, CSA, cTUVus, (RCM)	

1) One of the cable glands is used for the flow switch (DID with bypass flow cell)

2) Remark: a circuit breaker must be installed

3) Remark: depending on the load, additional snubber circuits might be required

## Sensors for disinfectants

		Chlori::lyser				Chlodi::lyser		Hyper::lyser		Peroxy::lyser		
		Free chlorine		Total chlorine		Chlorine dioxide		Hydrogen peroxide		Peracetic acid		
General data	Measuring range	ppm [mg/l]	0-2	0-20	0-2	0-20	0-2	0-20	0-200	0-2000	0-200	0-2000
	Accuracy	[%]	< 1 <sup>1)</sup>	< 1 <sup>2)</sup>	< 1 <sup>1)</sup>	< 1 <sup>2)</sup>	< 1 <sup>1)</sup>	< 1 <sup>2)</sup>	< 2 <sup>3)</sup>	< 0.5 <sup>4)</sup>	< 2 <sup>3)</sup>	< 0.5 <sup>4)</sup>
	Resolution	ppm [mg/l]	0.001	0.01	0.001	0.01	0.001	0.01	0.1	1	0.1	1
	Measuring principle	-	Amperometric, 3 electrodes, membrane-covered				Amperometric, 2 electrodes, membrane-covered					
	Temperature compensation	-	Yes		Yes		Yes		Yes		Yes	
	pH compensation	-	Yes		Yes		-		-		-	
	Response time (T90)	[minute]	2		2		1		8		5 at 10 °C 1.5 at 50 °C	
	Run-in time (during startup, after power-off)	[hour]	2		2		1		3		3	
Ambient conditions	Operating temperature (liquid temperature)	[°C]	5-45		5-45		5-50		5-45		5-45	
	Max. pressure (on outlet, without pressure peaks or fluctuation)	[bar]	0.5		0.5		1		1		1	
	Recommended flow (DID with flow cell)	[l/h]	30		30		30		30		30-100	
	Recommended flow speed (DID for tank immersion)	[m/s]	0.015 - 0.06		0.015 - 0.06		0.015 - 0.06		0.015 - 0.06		0.015 - 0.06	
	pH operating range	[pH]	4-9		4-12		2-11		2-11		1-6	
Cross sensitivities	Influence of pH on reading	-	Up to pH 7: no influence Up to pH 9: 10 % of electrode slope		Between pH 4 and 12: 5 % of electrode slope per pH unit		No influence		No influence		No influence	
	Influence of ClO <sub>2</sub> : Reading instead of parameter	[%]	75		75		-		n/A		100	
	Influence of Cl <sub>2</sub> : Reading instead of parameter	[%]	-		-		0		Must not be present		0	
	Influence of O <sub>3</sub> : Reading instead of parameter	[%]	80		130		2500		Must not be present		2500	
	Influence of other substances	-	Combined chlorine can increase reading		-		-		PES or PAA must not be present. Sulfide and phenole poison or destroy the membrane system.		No influence of H <sub>2</sub> O <sub>2</sub>	
Material and design	Enclosure class	-	IP67		IP67		IP67		IP67		IP67	
	Housing materials	-	PVC-U, PEEK SS 1.4571		PVC-U, PEEK SS 1.4571		PVC-U SS 1.4571		PVC-U SS 1.4571		PVC-U SS 1.4571	
Storage data	Storage temperature of sensor	[°C]	0-45									
	Storage temperature of electrolyte	[°C]	10-35									
	Storage conditions	-	Dry, without electrolyte, with clean membrane cap									
	Max. storage time of electrolyte	years	1-2 (check expiry date on package)									
Approvals	-	CE (EN 61326-1:2013)										

1) at 0.4 ppm and at 1.6 ppm

2) at 1.5 ppm

3) at 40 ppm and at 160 ppm

4) at 40 ppm and < 2 % at 1600 ppm

## Sensors for pH, ORP and conductivity

		pH::lyser pH	Redo::lyser ORP	Condu::lyser Conductivity	
General data	Measuring principle	-	Potentiometric, with combined non-porous reference electrode	4-electrode, direct contact	
	Measuring range of main parameter	-	pH 2-12	-2000 to +2000 mV	
	Measuring range of temperature	[°C]	0-70	0-70	
	Temperature compensation	-	Yes, with PT100 (class B)	no	
	Resolution of main parameter	-	pH 0.01	1 mV	
	Resolution of temperature	[°C]	0.1	0.1	
	Accuracy	-	± 0.1 pH	± 10 mV in standard solution	± 0.1 % of current reading in standard solution
	Response time (T90)	[s]	30	30	60
Ambient conditions	Run-in time (during startup)	[hour]	< 1		
	Operating temperature	[°C]	0-70		
	Operating pressure range	[bar]	0-10		
	Recommended range flow speed (submersed installation)	[m/s]	0.01-3		
Material and design	Enclosure class (sensors with plug)	-	IP67		
	Enclosure class (sensors with cable)	-	IP68		
	Housing materials	-	Stainless steel 1.4571, POM-C		
	Sensor materials	-	-	-	Stainless steel 1.4435, PEEK, EPDM
Storage data	Storage temperature of sensor	[°C]	0-90		
	Storage time	-	Approx. one year with filled protective cap (check expiry date on package)		
Approvals	-	CE (EN 61326-1:2013)			

## Hydraulic installation

## BF1 and BF3 variants with bypass flow cell

Data	Units	BF1	BF3
General data	Number of connectable S::CAN sensors	1	3
	Min. liquid temperature*	[°C]	0.1
	Max. liquid temperature*	[°C]	45
	Min. ambient temperature*	[°C]	0.1
	Max. ambient temperature*	[°C]	45
Hydraulic data	Min. flow rate	[l/h]	30
	Max. flow rate (integrated limitation)	[l/h]	60
	Max. pressure at inlet	[bar]	3
	Min. pressure at inlet	[bar]	0.5
	Max. pressure at outlet (non fluctuating)	[bar]	0.5
Connection data	Inlet/outlet: internal thread	["]	Rp1/2
	Inlet/outlet: threaded connection size	-	G 5/8
	Inlet/outlet: hose connections, metric (ID/OD)	[mm]	4/6, 6/9, 6/12 or 9/12
	Inlet/outlet: hose connections, inch (IDxOD)	["]	0.17 x 1/4, 1/4 x 3/8 or 3/8 x 1/2
Sample water outlet: hose barb	[mm]	4	

\* Check data of sensor and CU 382 control unit, too. The lowest value defines the actual operating limits.

## T11 and T12 variants for tank immersion

Data		Units	T11	T12
General data	Number of connectable S::CAN sensors		1	2
	Min. liquid temperature*	[°C]	0.1	
	Max. liquid temperature*	[°C]	45	
	Min. ambient temperature*	[°C]	0.1	
	Max. ambient temperature*	[°C]	45	
Hydraulic data	Max. flow speed*	[m/s]	See sensor data	
	Max. pressure*	[bar]	10	
Connection data	Prepared for metric pipe dimension (OD)	[mm]	50	
	Prepared for inch pipe dimension (OD)	["]	2	

\* Check data of sensor and CU 382 control unit, too. The lowest value defines the actual operating limits.

## Weights

Description	Without packaging	With packaging	Product number
	[kg]	[kg]	
DID-1 BF1-FCL2	4.26	8.10	98915656
DID-1 BF1-CDI2	4.26	8.10	98915657
DID-1 BF1-PA2	4.26	8.10	98915658
DID-1 BF1-HP2	4.26	8.10	98915659
DID-3 BF3-FCL2/TCL2	4.72	8.78	98915660
DID-3 BF3-FCL2/PH	4.71	8.77	98915661
DID-3 BF3-FCL2/TCL2/PH	4.97	9.18	98915662
DID-3 BF3-FCL2/ORP	4.71	8.77	98915663
DID-3 BF3-FCL2/PH/ORP	4.96	9.17	98915664
DID-1 BF1-PH	4.25	8.09	98915665
DID-1 T11-PH	2.08	5.88	98915666
DID-1 T11-ORP	2.08	5.88	98915667
DID-3 T12-ORP/PH	2.85	6.80	98915668
DID-3 BF3-ORP/PH	4.70	8.76	98915669
DID-1 BF1-CND	4.25	8.09	98915670
DID-1 T11-CND	2.08	5.88	98915671

## 6. Dimensions

### DID with flow cell BF1

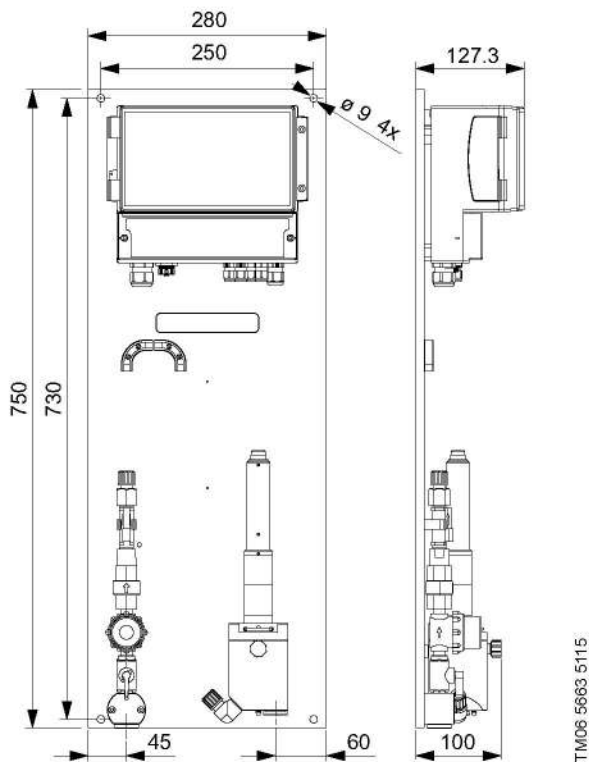

Fig. 7 Dimensions of DID with flow cell, GF1 installation variant, for 1 sensor (in mm)

### DID with flow cell BF3

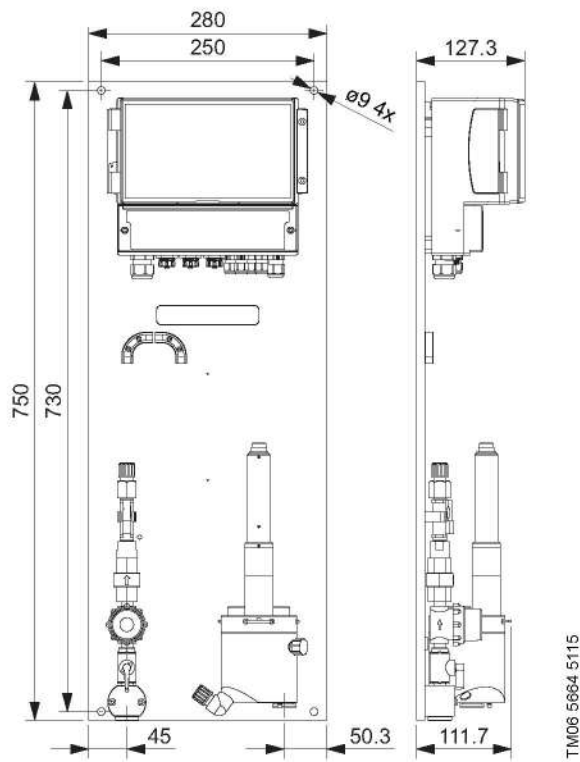

Fig. 8 Dimensions of DID with flow cell, BF3 installation variant, for up to 3 sensors (in mm)

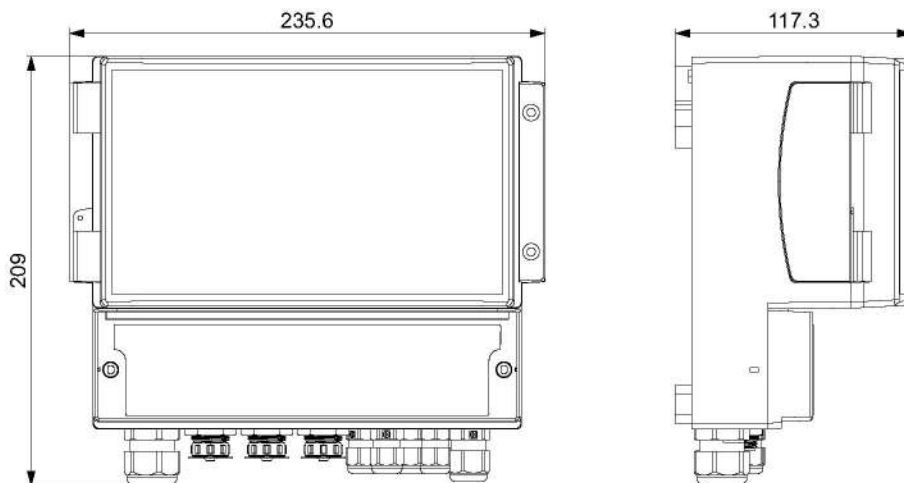
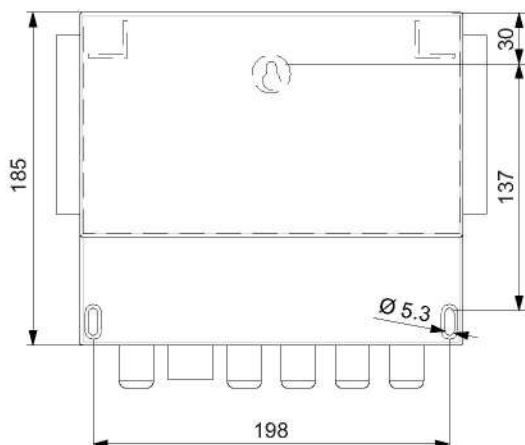

Fig. 9 Dimensions of CU 382 control unit, front and side view (in mm)

## DID for wall mounting and sensor with holder



**Fig. 10** Dimensions of CU 382 control unit for wall-mounting, back (in mm)

TM06 b5979 0316

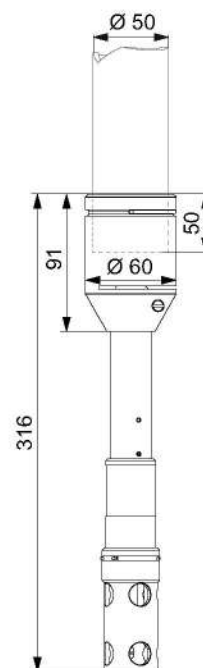

**Fig. 11** Dimensions of sensor with holder (in mm), pipe with outside diameter 50 mm not included

TM06 5977 0316

## 7. Product selection

### Standard range DID pre-assembled system

#### DID with bypass flow cell, with flow switch

Purpose/applications	Parameter 1	Parameter 2	Parameter 3	Type key	Product number
Free chlorine dosing control <sup>1)</sup>	Free chlorine 0-2 ppm			DID-1 BF1-FCL2	98915656
ClO <sub>2</sub> dosing control	Chlorine dioxide 0-2 ppm			DID-1 BF1-CDI2	98915657
PAA dosing control	Peracetic acid 0-200 ppm			DID-1 BF1-PA2	98915658
H <sub>2</sub> O <sub>2</sub> dosing control	Hydrogen peroxide 0-200 ppm			DID-1 BF1-HP2	98915659
Chloramine dosing control or chlorine dosing control with monitoring of total chlorine	Free chlorine 0-2 ppm	Total chlorine 0-2 ppm		DID-3 BF3-FCL2/TCL2	98915660
Free chlorine dosing control + pH control <sup>2)</sup>	Free chlorine 0-2 ppm	pH 2-12		DID-3 BF3-FCL2/PH	98915661
Chloramine dosing control or chlorine dosing control with monitoring of total chlorine + pH control <sup>2)</sup>	Free chlorine 0-2 ppm	Total chlorine 0-2 ppm	pH 2-12	DID-3 BF3-FCL2/TCL2/PH	98915662
Free chlorine dosing control with validation via ORP <sup>1)</sup>	Free chlorine 0-2 ppm	ORP -2000 to +2000 mV		DID-3 BF3-FCL2/ORP	98915663
Free chlorine dosing control with validation via ORP + pH control <sup>2)</sup>	Free chlorine 0-2 ppm	pH 2-12	ORP -2000 to +2000 mV	DID-3 BF3-FCL2/PH/ORP	98915664
pH control (neutralisation, pH adjustment for further processes), dosing control of acids and bases	pH 2-12			DID-1 BF1-PH	98915665
Dosing control in oxidation/reduction processes (e.g. removal of chromic acid, nitrite or cyanide)	ORP -2000 to +2000 mV	pH 2-12		DID-3 BF3-ORP/PH	98915669
Chemical dosing control in CIP-processes, high-purity water, cooling towers	Conductivity 1-500000 µS/cm			DID-1 BF1-CND	98915670
Without sensors, allows customisation according to specific application requirements, up to 3 sensors are possible				DID-3 BF3	99083725

1) With internal pH compensation up to pH 8.5

2) Provides additional pH compensation of chlorine measurement for highest accuracy

#### DID for tank immersion

Purpose/applications	Parameter 1	Parameter 2	Type key	Product number
pH control (neutralisation for further processes), dosing control of acids and bases	pH 2-12		DID-1 TI1-PH	98915666
Denitrification, monitoring of the disinfection effect when dosing oxidising agents, etc.	ORP -2000 to +2000 mV		DID-1 TI1-ORP	98915667
Dosing control in oxidation/reduction processes (e.g. removal of chromic acid, nitrite or cyanide)	ORP -2000 to +2000 mV	pH 2-12	DID-3 TI2-ORP/PH	98915668
Chemical dosing control in CIP-processes, high-purity water, cooling towers	Conductivity 1-500000 µS/cm		DID-1 TI1-CND	98915671

## 8. Accessories and maintenance kits

### Accessories

#### Mains cables

Cable length: 2.0 m

Plug type	Product number
Europe	99074491
USA	99074492
Australia	99074493

#### Sensor cables

- Connection of sensor and control unit
- Extension to bridge long distances between sensor and control unit

Use	Cable length [m]	Product number
DID with flow cell: cable for connection of sensor and control unit	1	98915690
DID with flow cell and DID for tank immersion: extension cable for long distance connection of sensor and control unit	10	98915691
	20	98915692

#### Sensors

Individual sensors for customised solutions or add-on to standard systems. All sensors include temperature measurement in addition to the main parameter.

##### DID with flow cell

- Sensors with plug

Parameter	Measuring range	Product number
Free chlorine (FCI)	0-2 ppm	98915674
	0-20 ppm	98915675
Total chlorine (TCI)	0-2 ppm	98915676
	0-20 ppm	98915677
Chlorine dioxide (CDI)	0-2 ppm	98915678
	0-20 ppm	98915679
Hydrogen peroxide (HP)	0-200 ppm	98915680
	0-2000 ppm	98915681
Peracetic acid (PA)	0-200 ppm	98915682
	0-2000 ppm	98915683
pH	pH 2-12	98915684
ORP	-2000 mV to +2000 mV	98915686
Conductivity (CND)	1-500000 µS/cm (2-42 PSU)	98915688

##### DID for tank immersion

- Sensors with 7.5 m of fixed cable

Parameter	Measuring range	Product number
pH	pH 2-12	98915685
ORP	-2000 mV to +2000 mV	98915687
Conductivity (CND)	1-500000 µS/cm (2-42 PSU)	98915689

#### CU 382 control unit

Individual control units for customised solutions or as a replacement.

Control unit type	Number of sensor connectors	Product number
CU 382-1	1	98915672
CU 382-3	3	98915673

#### Hydraulic installation components

Installation type	Components	Product number
DID with bypass flow cell	Inlet connection, shut-off valve, strainer, flow restrictor, flow switch, connecting hose	99074484
	Flow cell for 1 sensor, sampling cock and outlet, outlet connection	99074485
	Flow cell for 3 sensors, sampling cock and outlet, outlet connection	99074486
DID for tank immersion	Sensor holder	99074490
	Sensor guard	99074487
	Cleaning valve (for use with a compressed-air installation)	99074488
	Cleaning assembly with valve and compressor (if no compressed air is available on site)	99074489

#### Anti-siphoning pressure-loading valve

Mounted on the outlet connection of DID with bypass flow cell.

Prevents siphoning in case the outlet to the drain is far below the DID system.

Description	Product number
Pressure loading valve to prevent siphoning	96609179



### Sample water extraction devices

Sample water extraction devices are used to extract a part of the main water flow.

Sample water extraction devices consist of:

- An extraction pipe that is immersed into the water flow to be measured.
  - The pipe can be cut to length to match installation conditions on site.
  - With R 1/2" installation connection
- A ball valve to stop the water flow to the DID system.

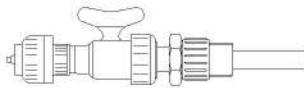

TM06 5648 5115

Fig. 12 Sample water extraction device

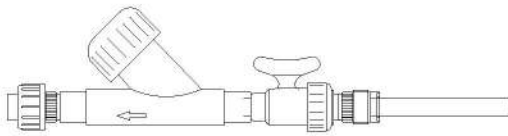

TM06 5649 5115

Fig. 13 Sample water extraction device

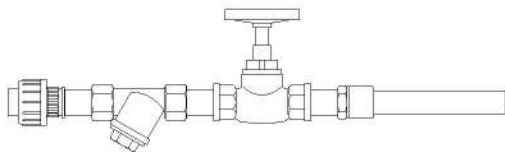

TM06 5650 5115

Fig. 14 Sample water extraction device

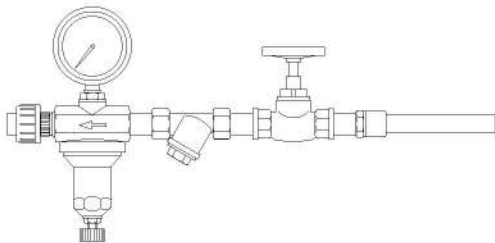

TM06 5651 5115

Fig. 15 Sample water extraction device

Description	Product number
Max. 3 bar, PVC (Fig. 12)	96729302
Max. 3 bar, PVC, with filter (Fig. 13)	96729301
Max. 3 bar, brass, with filter (Fig. 14)	96729300
Max. 10 bar, brass, with filter, pressure reducing valve and manometer (Fig. 15)	96698139

### Sample water extraction pump

In case the installation on site does not allow free water flow to the DID system, a sample water extraction pump can be used to transport the water.

- Connection DN8
- Mains voltage and frequency 220 V, 50 Hz
- Power consumption approx. 40 W

Description	Product number
Sample water extraction pump, up to 35 l/h	95701524

### External water filters

An additional external water filter might be necessary when more dirt is expected in the water to be measured.

Note: all DID systems with bypass flow cell have an integrated water filter.

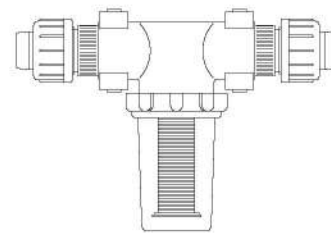

TM06 5652 5115

Fig. 16 External water filter without ball valve

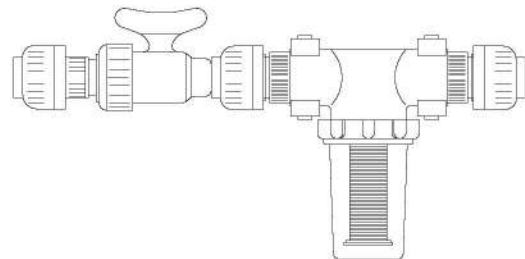

TM06 5653 5115

Fig. 17 External water filter with ball valve

Description	Product number
External water filter, with ball valve	96622995
External water filter, without ball valve	95709473

## KCl solution for safe storage of pH and ORP sensors

The tips of ORP and pH sensors must be wetted with 3-molar potassium chloride (KCl) solution during storage.

Description	Product number
Bottle of KCl solution for safe storage of pH and ORP sensors, 250 ml	96688696

## Buffer solution kit for pH sensor calibration

The buffer solution kit includes three buffer solutions with pH 4.01, pH 7 and pH 9.18.

Description	Product number
Buffer solution kit, 3 x 100 ml	96609165

## Maintenance kits

### Maintenance kits for disinfectant sensors

Maintenance kits for disinfectant sensors include a bottle of electrolyte and a membrane cap.

When used under normal conditions with ordinary water, a sensor can be operated for one year with a maintenance kit.

The electrolyte must be exchanged twice a year, the membrane cap once a year.

Maintenance kit for parameter	Product number
Free chlorine (FCI)	99074494
Total chlorine (TCI)	99074495
Chlorine dioxide (CDI)	99074496
Hydrogen peroxide (HP)	99074497
Peracetic acid (PA)	99074498

### Maintenance kits for pH and ORP sensors

Maintenance kits for pH and ORP sensors include an electrode to replace the one included in the sensor.

Depending on the water quality, the electrode must be replaced after 1-3 years.

Maintenance kit for parameter	Product number
pH	99074499
ORP	99074500

## 9. Grundfos Product Center

Online search and sizing tool to help you make the right choice.

<http://product-selection.grundfos.com>



**SIZING** enables you to size a pump based on entered data and selection choices.

**REPLACEMENT** enables you to find a replacement product. Search results will include information on

- the lowest purchase price
- the lowest energy consumption
- the lowest total life cycle cost.

The screenshot shows the Grundfos Product Center website. At the top, there is a navigation bar with the Grundfos logo and 'PRODUCT CENTER'. Below this is a search bar with a 'SEARCH' button. The main content area features four large buttons: 'SIZING' (with a subtext 'Enter pump sizing'), 'CATALOGUE' (with a subtext 'Products and services'), 'REPLACEMENT' (with a subtext 'Replace an old pump with a new'), and 'LIQUIDS' (with a subtext 'Find pump by liquid'). Below these buttons is a 'QUICK SIZING' section with input fields for 'Flow (Q)\*' and 'Head (H)\*', and radio buttons for 'Select what to size by: Size by application', 'Size by pump design', and 'Size by pump family'. A 'START SIZING' button is also present. At the bottom of the screenshot, there are callout boxes explaining each feature: 'SIZING' (described as a tool for entering data and making choices), 'REPLACEMENT' (described as a tool for finding replacement products based on price, energy, and life cycle cost), 'CATALOGUE' (described as access to the product catalogue), and 'LIQUIDS' (described as a tool for finding pumps for special liquids).

**SIZING** enables you to size a pump based on entered data and selection choices.

**REPLACEMENT** enables you to find a replacement product. Search results will include information on

- the lowest purchase price
- the lowest energy consumption
- the lowest total life cycle cost.

**CATALOGUE** gives you access to the Grundfos product catalogue.

**LIQUIDS** enables you to find pumps designed for aggressive, flammable or other special liquids.

### All the information you need in one place

Performance curves, technical specifications, pictures, dimensional drawings, motor curves, wiring diagrams, spare parts, service kits, 3D drawings, documents, system parts. The Product Center displays any recent and saved items - including complete projects - right on the main page.

### Downloads

On the product pages, you can download installation and operating instructions, data booklets, service instructions, etc. in PDF format.

Subject to alterations.

98963792 0616

ECM: 1165028

**GRUNDFOS A/S**  
DK-8850 Bjerringbro . Denmark  
Telephone: +45 87 50 14 00  
[www.grundfos.com](http://www.grundfos.com)

**GRUNDFOS** 

## Stația de clorinare containerizată cu 1 sistem de clorinare cu hipoclorit

Stația de clorinare este prevăzută cu o linie de măsurare a debitului și de injecție a hipocloritului.

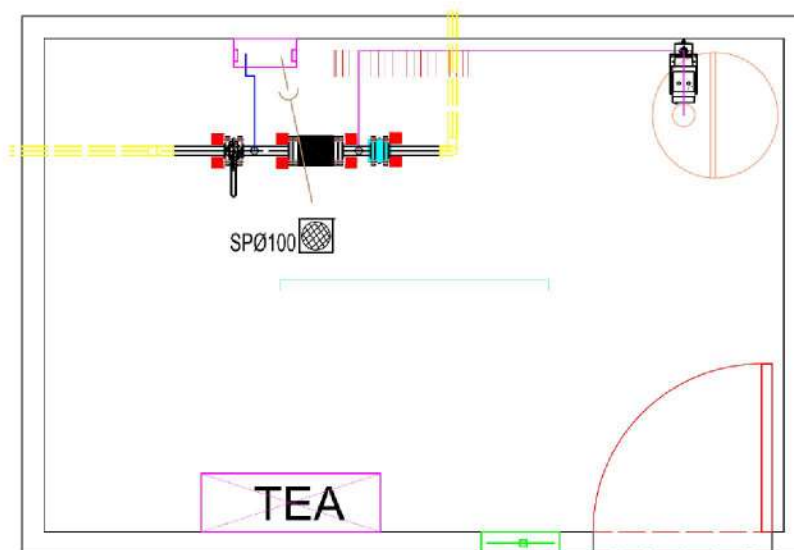

Stația de clorinare este amplasată într-un container, cu o singură încăpere, cu stâlpi de susținere profilați la rece din tablă zincată cu grosimea de 2 mm, pereți din panou sandwich poliuretan tip C 1 RAL 9002 (garantat 10 ani), acoperiș cu rezistență portantă de 250 kg/m<sup>2</sup>, format din structură metalică zincată profilată la rece, grunduită reactiv și vopsită, tablă zincată dublu fălțuită, grosime 0,5 mm, folie anticondens, vată minerală grosime 100 mm norma C1 ISOVER®, tavan PVC RAL 9002, prevăzută cu o ușă laterală cu dimensiunile 900x2000 mm, PVC/metalică.

Containerul este încălzit utilizând un convector electric termostatat cu puterea de 2000 W, cu montare murală și cu un ventilator axial, cu montare murală, cu funcționare temporizată, cu debitul de 1300 m<sup>3</sup>/h, 230 Va.c., 60 W.

Stația poate fi livrată în mai multe variante configurate în funcție de diametrul liniei de măsură și injecție. Diametre disponibile pentru conducte: DN40, DN50, DN65, DN80, DN100, DN125, DN150, DN200.

Linia de măsurare a debitului și de injecție este cu următoarele echipamente:

- robinet de izolare la intrare;

- debitmetru electromagnetic;
- sistem de analiză clor rezidual;
- sistem de dozare hipoclorit;
- robinet acționat electric la ieșirea liniei.

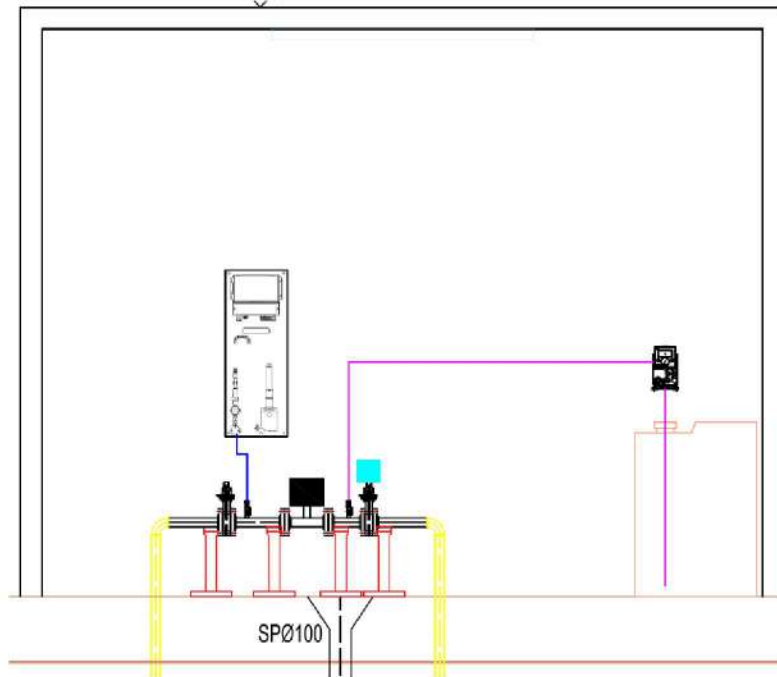

Debitmetrul montat pe linie are următoarele caracteristici:

- conectarea la proces: flanșa EN 1092-1;
- grad de protecție: IP 67;
- carcasă și flanșe: oțel carbon, acoperire anticorozivă cu vopsea epoxidică (min. 150  $\mu\text{m}$ );
- țevă de măsură: inox AISI 304/1.4301;
- electrozi: hastelloy C;
- transmiter, montaj compact, precizie de măsurare  $\pm 0,4 \%$ , o ieșire analogică 4-20mA, o ieșire digitală, o ieșire pe releu, display retroiluminat cu text alfanumeric 3x20 caractere, IP67, alimentare 115-230 Vc.a., temperatura de operare  $-20\div 50 \text{ }^\circ\text{C}$ .

Sistem de analiză clor rezidual montat pe linie are următoarele caracteristici:

- alimentare: 220 Vc.a.;
- sistem preasamblat al unității de control și al celulei de măsură;
- sistem de prelevare a probei de apă pentru analiza concentrației de clor rezidual;
- măsurarea și controlul continuu a concentrației clorului rezidual, cu posibilitatea de compensare a temperaturii;
- gama de măsură a clorului rezidual: 0-2 mg/l;
- senzor de temperatura a apei;
- presiune maxima de lucru: 3 bar.

Sistemul de dozare montat pe linie are următoarele caracteristici:

- pompă dozatoare digitală (220VAC, 16bar, afișaj LCD, modul interfațare SCADA, intrări și ieșiri digitale, intrări și ieșiri analogice), cu funcționare automată în funcție de debitul apei pompate și de valoarea clorului rezidual măsurată de instalația de analiză;
- rezervor de stocare soluție de hipoclorit, 200 litri, material PE, prevăzut cu robinet de golire;
- agitator manual;
- linie de aspirație rigidă, cu: sorb aspirație, clapetă de sens și senzor de rezervor gol;
- supapă multifuncțională, pentru: prevenirea sifonării, menținerea constantă a contrapresiunii și reducerea manuală a presiunii;
- furtun dozare hipoclorit;
- unitate de injecție hipoclorit, cu supapă pentru prevenirea cristalizării și blocării dozării hipocloritului în apa care are un conținut ridicat de carbonați.

Stația de clorinare este prevăzută cu un tablou electric, de automatizare și control al procesului cu următoarele caracteristici principale:

- echipat cu inversor manual de sursă, pentru posibilitatea conectării unui grup generator portabil (în sursa 1 se va conecta alimentarea din rețeaua electrică, iar în sursa 2 se va conecta o fișă industrială monofazată (230 V), montată aparent pe peretele exterior al tabloului electric);
- dotat cu echipamente pentru protecția și comanda dozatoarelor de hipoclorit;
- dotat cu echipamente de protecție pentru debitmetre;
- dotat cu siguranțe automate diferențiale pentru circuitele de iluminat și încălzire;
- dotat cu priză 230 Vc.a. monofazată pentru serviciile interne;
- dotat cu modul de protecție la supratensiuni atmosferice și de comutație;

Pentru monitorizarea/controlul parametrilor procesului tehnologic, precum și pentru comunicația cu un sistem SCADA, în tabloul electric și de automatizare este prevăzut un PLC cu router GSM/GPRS integrat și sistem UPS cu acumulatori tampon. Pe ușa tabloului electric este amplasat un afișaj de 7" pentru urmărirea parametrilor procesului de către operator, precum și pentru programarea valorilor de referință.

Principalele date ce pot fi transmise către un dispecerat SCADA sunt următoarele:

- starea de funcționare a analizoarelor de clor și a sistemelor de dozare;
- parametrii electrici ai stației de clorinare;
- debitele instantanee și totalizatoarele;
- prezența tensiunii de alimentare;
- starea comunicației GPRS;
- regim stație de clorinare;
- cantitate de clor/puls programată;
- concentrație de clor programată;

- alarmă nivel scăzut hipoclorit în rezervor;
- alarmă sisteme clorinare;
- volum de clor dozat;
- număr de porniri ale pompelor dozatoare de clor;
- orele de funcționare ale pompelor dozatoare de clor;
- temperatura apei.



# Uninterruptible power supply - TRIO-UPS/1AC/24DC/5 - 2866611

Please be informed that the data shown in this PDF Document is generated from our Online Catalog. Please find the complete data in the user's documentation. Our General Terms of Use for Downloads are valid (<http://phoenixcontact.com/download>)



Uninterruptible power supply with integrated power supply unit, 5A, in combination with MINI-BAT/24/DC/1.3 AH, QUINT-BAT/24DC 3,4AH, 7,2AH or 12 AH

## Product Description

The TRIO UPS module with integrated power supply is particularly space-saving: UPS module and power supply in one housing. Only one energy storage is required to complete the UPS system.

Energy storage with lead AGM technology buffers failures lasting up to two hours with 5 A load current.

## Your advantages

- Autonomous – in the event of AC mains failure the industrial PC continues operating without interruption
- Time saving – when the supply voltage is restored, the industrial PC starts automatically



## Key Commercial Data

Packing unit	1 pc
GTIN	
GTIN	4046356311809
Weight per Piece (excluding packing)	1,147.000 g
Custom tariff number	8537 1091
Country of origin	China

## Technical data

### Dimensions

Width	60 mm
Height	130 mm
Depth	118 mm

### Ambient conditions

Degree of protection	IP20
Ambient temperature (operation)	-25 °C ... 70 °C (> 55° C derating : 2.5%/K)
Ambient temperature (storage/transport)	-40 °C ... 80 °C

# Uninterruptible power supply - TRIO-UPS/1AC/24DC/5 - 2866611

## Technical data

### Ambient conditions

Max. permissible relative humidity (operation)	95 % (at 25 °C, non-condensing)
Climatic class	3K3 (in acc. with EN 60721)
Degree of pollution	2

### Input data

Nominal input voltage range	100 V AC ... 240 V AC
AC input voltage range	85 V AC ... 264 V AC (Derating < 90 V AC: 2.5%V)
Input voltage range DC	100 V DC ... 350 V DC (UL508: 100 ... 250 V)
Buffer time	adjustable: 0.5 min; 1 min; 2 min; 3 min; 5 min; 10 min; 15 min; 20 min; PC-Mode
Current consumption	1.1 A (230 V AC, maximum) 1.8 A (120 V AC, maximum)
Inrush current limiting/I <sup>2</sup> t	< 1.3 A <sup>2</sup> s
Mains buffering time	see diagram
Typical response time	150 ms (230 V AC) 200 ms (120 V AC)
Power factor (cos phi)	approx. 0.5
Protective circuit	Transient surge protection Varistor
Input fuse, integrated	6.3 A (slow-blow, internal)

### Output data

Nominal output voltage	24 V DC
Setting range of the output voltage (U <sub>set</sub> )	22.5 V DC ... 29.5 V DC (Network operation; in the buffer mode, dependent on the battery voltage of 27.9 V DC ... 19.2 V DC)
Nominal output current (I <sub>N</sub> )	5 A (-25 °C ... 55 °C)
Derating	55 °C ... 70 °C (2.5%/K)
Output current limit	max. 6 A (Mains operation)
Control deviation	< 1 % (change in load, static 10 % ... 90 %)
Efficiency	> 88 % (230 V AC, network operation) > 86 % (120 V AC, network operation) > 86 % (Battery operation)
Residual ripple	< 10 mV <sub>pp</sub>
Peak switching voltages nominal load	< 25 mV <sub>pp</sub>
Connection in parallel	Yes, 2
Surge protection against internal surge voltages	< 35 V DC
Feedback voltage resistance	35 V DC

### General

IQ technology	no
Net weight	1.1 kg
Memory medium	External, battery 1.3 Ah / 3.4 Ah / 7.2 Ah / 12 Ah
Insulation voltage input/output	4 kV (type test) 2 kV (routine test)

# Uninterruptible power supply - TRIO-UPS/1AC/24DC/5 - 2866611

## Technical data

### General

Protection class	I
	> 596000 h (40 °C)
Mounting position	horizontal DIN rail NS 35, EN 60715
Assembly instructions	alignable: horizontally 0 mm, vertically 50 mm

### Connection data, input

Connection method	Screw connection
Conductor cross section solid min.	0.2 mm <sup>2</sup>
Conductor cross section solid max.	2.5 mm <sup>2</sup>
Conductor cross section flexible min.	0.2 mm <sup>2</sup>
Conductor cross section flexible max.	2.5 mm <sup>2</sup>
Conductor cross section AWG min.	24
Conductor cross section AWG max.	12
Screw thread	M3

### Connection data, output

Connection method	Screw connection
Conductor cross section solid min.	0.2 mm <sup>2</sup>
Conductor cross section solid max.	2.5 mm <sup>2</sup>
Conductor cross section flexible min.	0.2 mm <sup>2</sup>
Conductor cross section flexible max.	2.5 mm <sup>2</sup>
Conductor cross section AWG min.	24
Conductor cross section AWG max.	12
Stripping length	8 mm
Screw thread	M3

### Connection data for signaling

Conductor cross section solid min.	0.2 mm <sup>2</sup>
Conductor cross section solid max.	2.5 mm <sup>2</sup>
Conductor cross section flexible min.	0.2 mm <sup>2</sup>
Conductor cross section flexible max.	2.5 mm <sup>2</sup>
Conductor cross section AWG min.	24
Conductor cross section AWG max.	12
Screw thread	M3

### Charging process

Charge characteristic curve	I/U characteristic curve
Battery presence check/time interval	60 s
Charge current	0.2 A ... 1.5 A (Default 1.0 A)
End-of-charge voltage	25 V DC ... 30 V DC (Default 27.6 V DC)
Temperature compensation	0 mV/K ... 200 mV/K (42 mV/K by default)
Quality check of battery	4 h ... 200 h (Default 12 h)
Deep discharge protection	18 V DC ... 21 V DC (Default 19.2 V DC)

# Uninterruptible power supply - TRIO-UPS/1AC/24DC/5 - 2866611

## Technical data

### Charging process

Alarm signaling threshold	18 V DC ... 30 V DC (Default 20.4 V DC)
---------------------------	---

### Standards and Regulations

Electromagnetic compatibility	Conformance with EMC Directive 2014/30/EU
Noise emission	EN 55011 (EN 55022)
Noise immunity	EN 61000-6-2:2005
Connection in acc. with standard	CUL
Standards/regulations	EN 61000-4-2
Contact discharge	6 kV
Standards/regulations	EN 61000-4-3
Frequency range	80 MHz ... 2 GHz
Test field strength	10 V/m
Standards/regulations	EN 61000-4-4
Comments	Criterion B
Standards/regulations	EN 61000-6-3
	EN 61000-4-6
Frequency range	10 kHz ... 80 MHz
Voltage	10 V
Standards/regulations	EN 61000-4-11
Low Voltage Directive	Conformance with Low Voltage Directive 2014/35/EC
Standard - Electrical safety	EN 60950-1/VDE 0805 (SELV)
Standard – Electronic equipment for use in electrical power installations and their assembly into electrical power installations	EN 50178/VDE 0160 (PELV)
Standard – Safety extra-low voltage	EN 60950-1 (SELV)
	EN 60204 (PELV)
Standard - Safe isolation	DIN VDE 0100-410
Standard – Protection against shock currents, basic requirements for protective separation in electrical equipment	EN 50178
Standard – Limitation of mains harmonic currents	EN 61000-3-2
Shipbuilding approval	DNV GL (EMC B)
UL approvals	UL/C-UL listed UL 508
	UL/C-UL Recognized UL 60950-1
Shock	18 ms, 30g, in each space direction (according to IEC 60068-2-27)
Vibration (operation)	< 15 Hz, amplitude ±2.5 mm (according to IEC 60068-2-6)
	15 Hz ... 150 Hz, 2.3g, 90 min.
Rail applications	EN 50121-4

### Environmental Product Compliance

China RoHS	Environmentally Friendly Use Period = 25;
	For details about hazardous substances go to tab "Downloads", Category "Manufacturer's declaration"

## Drawings

# Uninterruptible power supply - TRIO-UPS/1AC/24DC/5 - 2866611

Block diagram

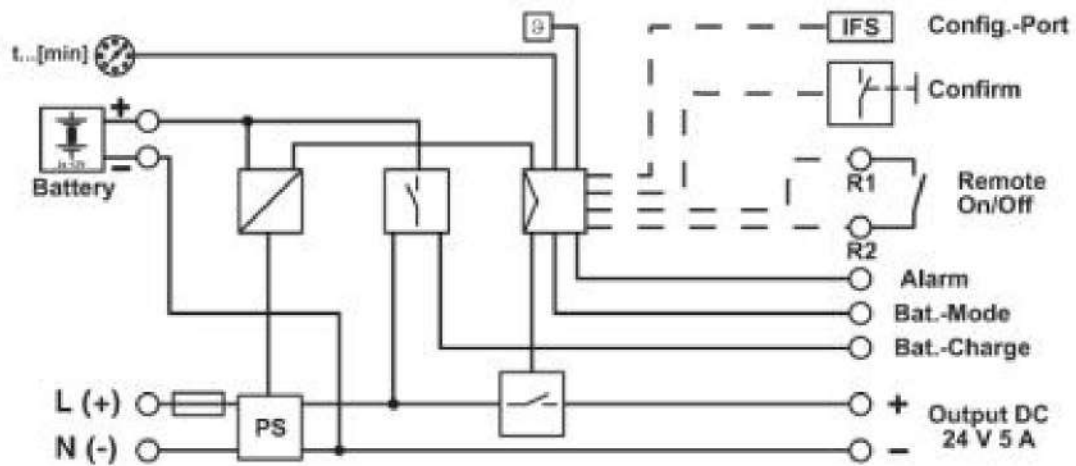

Diagram

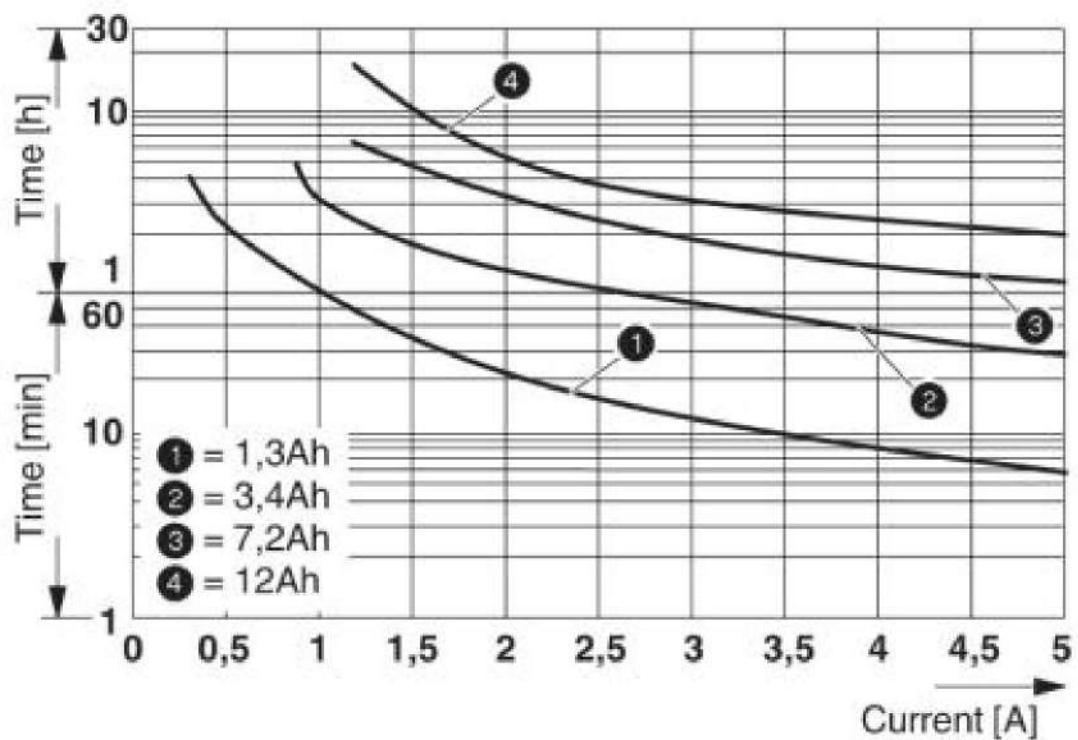

## Classifications

eCl@ss

eCl@ss 4.0	27040600
eCl@ss 4.1	27040600
eCl@ss 5.0	27040600
eCl@ss 5.1	27040600

# Uninterruptible power supply - TRIO-UPS/1AC/24DC/5 - 2866611

## Classifications

### eCl@ss

eCl@ss 6.0	27040600
eCl@ss 7.0	27040603
eCl@ss 8.0	27040603
eCl@ss 9.0	27040705

### ETIM

ETIM 2.0	EC000382
ETIM 3.0	EC000382
ETIM 4.0	EC000382
ETIM 5.0	EC000382
ETIM 6.0	EC000382
ETIM 7.0	EC000382

### UNSPSC

UNSPSC 6.01	30211510
UNSPSC 7.0901	39121011
UNSPSC 11	39121011
UNSPSC 12.01	39121011
UNSPSC 13.2	39121011
UNSPSC 18.0	39121011
UNSPSC 19.0	39121011
UNSPSC 20.0	39121011
UNSPSC 21.0	39121011

## Approvals

### Approvals

#### Approvals

DNV GL / PRS / UL Listed / UL Recognized / cUL Recognized / cUL Listed / EAC / EAC / cULus Recognized / cULus Listed

#### Ex Approvals

### Approval details

DNV GL		<a href="https://approvalfinder.dnvgl.com/">https://approvalfinder.dnvgl.com/</a>	TAA00000A2
--------	--	---	------------

# Uninterruptible power supply - TRIO-UPS/1AC/24DC/5 - 2866611

## Approvals

PRS		<a href="http://www.prs.pl/">http://www.prs.pl/</a>	TE/2104/880590/16
-----	--	---	-------------------

UL Listed		<a href="http://database.ul.com/cgi-bin/XYV/template/LISEXT/1FRAME/index.htm">http://database.ul.com/cgi-bin/XYV/template/LISEXT/1FRAME/index.htm</a>	FILE E 123528
-----------	--	---	---------------

UL Recognized		<a href="http://database.ul.com/cgi-bin/XYV/template/LISEXT/1FRAME/index.htm">http://database.ul.com/cgi-bin/XYV/template/LISEXT/1FRAME/index.htm</a>	FILE E 211944
---------------	--	---	---------------

cUL Recognized		<a href="http://database.ul.com/cgi-bin/XYV/template/LISEXT/1FRAME/index.htm">http://database.ul.com/cgi-bin/XYV/template/LISEXT/1FRAME/index.htm</a>	FILE E 211944
----------------	--	---	---------------

cUL Listed		<a href="http://database.ul.com/cgi-bin/XYV/template/LISEXT/1FRAME/index.htm">http://database.ul.com/cgi-bin/XYV/template/LISEXT/1FRAME/index.htm</a>	FILE E 123528
------------	--	---	---------------

EAC			EAC-Zulassung
-----	--	--	---------------

EAC			RU*DE*08.B.01873/19
-----	--	--	---------------------

cULus Recognized			
------------------	--	--	--

cULus Listed			
--------------	--	--	--

## Accessories

Accessories

Assembly adapter

# Uninterruptible power supply - TRIO-UPS/1AC/24DC/5 - 2866611

## Accessories

Assembly adapters - QUINT-PS-ADAPTERS7/2 - 2938206



Assembly adapter for QUINT POWER 10A on S7-300 rail

Assembly adapters - UWA 182/52 - 2938235



Universal wall adapter for securely mounting the device in the event of strong vibrations. The device is screwed directly onto the mounting surface. The universal wall adapter is attached on the top/bottom.

## Battery unit

Energy storage - MINI-BAT/24DC/1.3AH - 2866417



Energy storage device, lead AGM, VRLA technology, 24 V DC, 1.3 Ah.

Energy storage - QUINT-BAT/24DC/ 3.4AH - 2866349



Energy storage device, lead AGM, VRLA technology, 24 V DC, 3.4 Ah. Connection via pin cable lug, 14 mm.

Energy storage - QUINT-BAT/24DC/ 7.2AH - 2866352



Energy storage device, lead AGM, VRLA technology, 24 V DC, 7.2 Ah. Connection via pin cable lug, 14 mm.



# Uninterruptible power supply - TRIO-UPS/1AC/24DC/5 - 2866611

## Accessories

Energy storage - QUINT-BAT/24DC/12AH - 2866365



Energy storage device, lead AGM, VRLA technology, 24 V DC, 12 Ah. Connection via pin cable lug, 14 mm.

---

Energy storage - UPS-BAT/VRLA/24DC/1.3AH - 2320296



Energy storage device, lead AGM, VRLA technology, 24 V DC, 1.3 Ah, tool-free battery replacement, automatic detection, and communication with QUINT UPS-IQ

---

Energy storage - UPS-BAT/VRLA/24DC/3.4AH - 2320306



Energy storage device, lead AGM, VRLA technology, 24 V DC, 3.4 Ah, tool-free battery replacement, automatic detection, and communication with QUINT UPS-IQ

---

Energy storage - UPS-BAT/VRLA/24DC/7.2AH - 2320319



Energy storage device, lead AGM, VRLA technology, 24 V DC, 7.2 Ah, tool-free battery replacement, automatic detection, and communication with QUINT UPS-IQ

---

Energy storage - UPS-BAT/VRLA/24DC/12AH - 2320322



Energy storage device, lead AGM, VRLA technology, 24 V DC, 12 Ah, tool-free battery replacement, automatic detection, and communication with QUINT UPS-IQ

---

## Data cable preassembled

# Uninterruptible power supply - TRIO-UPS/1AC/24DC/5 - 2866611

## Accessories

Data cable - IFS-USB-DATACABLE - 2320500



Used for communicating between industrial PCs and Phoenix Contact devices with the 12-pos. IFS data port, such as QUINT UPS or TRIO UPS.

---

## Fuse

Fuse - SI FORM C 15 A DIN 72581 - 0913676



Flat-type plug-in fuse, type C, color code: light blue, nominal current: 15 A

---

Fuse - SI FORM C 25 A DIN 72581 - 0913757



Flat-type plug-in fuse, type C, color code: white, nominal current: 25 A

---

## Memory block

Memory block - IFS-CONFSTICK-L - 2901103



Multi-functional memory block with handle for the INTERFACE system; for easy storage and back up of the configuration.

---

Memory block - IFS-CONFSTICK - 2986122



Multi-functional memory block for the INTERFACE systemf for easy storage and backup of the configuration.

---

## Mounting rail adapter

## Uninterruptible power supply - TRIO-UPS/1AC/24DC/5 - 2866611

### Accessories

DIN rail adapter - UTA 107 - 2853983

Universal DIN rail adapter, for screwing on switchgear



---

### Programming adapter

Programming adapter - IFS-USB-PROG-ADAPTER - 2811271



Programming adapter with USB interface, for programming with software. The USB driver is included in the software solutions for the products to be programmed, such as measuring transducers or motor managers.

## Touch panel - BTP 2070W - 1046666

Please be informed that the data shown in this PDF Document is generated from our Online Catalog. Please find the complete data in the user's documentation. Our General Terms of Use for Downloads are valid (<http://phoenixcontact.com/download>)



Touch panel with 17.8 cm/7" TFT-display (analog resistive (polyester)), 800 x 480 pixel(s) (WVGA), 262144 colors, Arm9™ i.MX28, 454 MHz, 2x COM (RS-232/422/485), 1x USB 2.0, Typ A, 1x USB 2.0, Typ B, 1 x Ethernet (10/100 Mbps), RJ45, Windows® CE 6.0 and user software: Visu+. (bus system: without)

### Your advantages

- Visu+ RT integrated as standard in all BTP 2000 devices
- Connection to all relevant control systems, thanks to a large number of available drivers
- Developed for basic applications with attractive price/performance ratio
- 3 display sizes in 16:9 format



### Key Commercial Data

Packing unit	1 pc
GTIN	 4 055626 642963
GTIN	4055626642963

### Technical data

#### Note

Utilization restriction	EMC: class A product, see manufacturer's declaration in the download area
-------------------------	---

#### Dimensions

Outer dimensions: width, height, depth	186 mm x 138 mm x 5 mm (Dimensions of the front plate)
Installation dimensions: width, height, depth	175 mm x 127 mm x 31 mm (Installation cutout)

#### Display

Display	17.8 cm/7" TFT
Screen resolution	800 x 480 Pixel(s) (WVGA)
Touch technology	analog resistive (polyester)
Brightness	300 cd/m <sup>2</sup> , typical (adjustable)
Backlighting	LED
Display backlight MTBF	20000 h

# Touch panel - BTP 2070W - 1046666

## Technical data

### Display

Colors	262144 colors
Reading angle left	70 °
Reading angle right	70 °
Reading angle top	50 °
Reading angle bottom	70 °

### Computer data

Processor	Arm9™ i.MX28, 454 MHz
Operating system	Windows® CE 6.0
User software	Visu+
RAM	128 MB DDR2 SDRAM
Mass storage	Flash, 512 MB
Network	1 x Ethernet (10/100 Mbps), RJ45
Interfaces	2x COM (RS-232/422/485)
	1x USB 2.0, Typ A
	1x USB 2.0, Typ B
Bus system	without
Slots	1x SD

### General

Housing material	Plastic
Mounting type	Front installation
Weight	400 g

### Ambient conditions

Degree of protection	IP66 (on the front), IP20 (on the back)
Ambient temperature (operation)	0 °C ... 50 °C
Ambient temperature (storage/transport)	-20 °C ... 85 °C
Permissible humidity (operation)	10 % ... 95 % (non-condensing)
Permissible humidity (storage/transport)	10 % ... 95 % (non-condensing)
Vibration (operation)	DIN EN 60068-2-6
Shock	DIN EN 60068-2-27

### Device supply

Typical current consumption	0.4 A
Power supply unit	24 V DC ±15 %

### Standards and Regulations

Shock	DIN EN 60068-2-27
Vibration (operation)	DIN EN 60068-2-6

### Environmental Product Compliance

REACH SVHC	Lead 7439-92-1
------------	----------------

# Touch panel - BTP 2070W - 1046666

## Approvals

Approvals

---

Approvals

EAC

---

Ex Approvals

UL Listed / cUL Listed / cULus Listed

---

## Approval details

EAC



RU C-  
DE.A\*08.B01708

## Accessories

Accessories

Data plug

D-SUB gender changer - VS-09-GC-ST/ST - 1652651



D-SUB contact insert, shell size 1, with nine signal contacts, type of contact pin, gender changer, fixing with 4-40 UNC thread

---

## Operating stylus

Touch pen - TOUCH PEN - 2701379



Touch pen for analog-resistive HMIs, silver coated. Delivery includes self-adhesive pen holder.

---

PCB plug

## Touch panel - BTP 2070W - 1046666

### Accessories

Printed-circuit board connector - MSTB 2,5/ 3-STF-5,08 - 1777992

PCB connector, nominal current: 12 A, rated voltage (III/2): 320 V, nominal cross section: 2.5 mm<sup>2</sup>, number of positions: 3, pitch: 5.08 mm, connection method: Screw connection with tension sleeve, color: green, contact surface: Tin



---

### Storage medium

USB memory stick - USB FLASH DRIVE - 2402809



USB memory stick, 8 GB

---

Disk drive - MICROSDHC-16GB - 1154696



Industrial grade 16 GB MicroSDHC 3DTLC

---

Disk drive - MICROSDHC-32GB - 1154699



Industrial grade 32 GB MicroSDHC 3DTLC

---

Phoenix Contact 2020 © - all rights reserved  
<http://www.phoenixcontact.com>

**PHOENIX CONTACT ROMANIA**  
Splaiul Unirii 165 Timpuri Noi Square TNO1, Etaj 1  
Bucuresti 030133  
Romania  
+40 21 350 88 12 - 3  
+40 37 448 56 32 - 7  
<http://www.phoenixcontact.ro>

# Debitmetru electromagnetic MAG5100W

## Descriere generala

SITRANS FM MAG 5100 W este un debitmetru electromagnetic construit special pentru aplicatii pe apa : potabila, reziduala, uzata, precum si pe aplicatii unde intervine namolul.

## Beneficii:

- Diametre : DN 15 - DN1200/2000.
- Conexiune cu flansa conform EN 1092-1 (DIN 2501), ANSI, AWWA, AS si JIS;
- Liner din cauciuc dur NBR si ebonita pentru toate aplicatiile pe apa ;
- Liner din EPDM pentru aplicatii cu apa potabila ;
- Electrozi de masura si impamantare integrati realizati din hastelloy ;
- Precizie crescuta la debit scazut, datorita design-ului (DN 15 - DN300 mm);
- Aprobari pentru apa potabila ;
- Poate fi ingropat sau inundat ;
- Aprobare pentru tranzactii fiscale ;
- Constructie in conformitate cu ISO 13359 ; standardul incluzand diametre pana la DN400 ;
- Punere in functiune facila, valorile de calibrare si setarile fiind incarcate automat in SENSORPROM ;
- Proiectat astfel incat sa se efectueze verificarea in-situ, utilizandu-se amprenta SENSORPROM-ului ;
- Optiunea Custody Transfer pentru tranzactii fiscale, conform OIML R 49 si verificata conform MI-001
- Indeplineste directivele EEC: PED, directiva 97/23/EC pentru flanse EN1092-1
- Upgrade simplu in fabrica sau la locul de functionare a unui senzor standard la IP68/NEMA 6P.



## Aplicatii

Principalele aplicatii ale senzorilor MAG5100W sunt :

- Captarea apei;
- Tratarea apei
- Rețele de distributie a apei (managementul detectiei scurgerilor) ;
- Masurari pentru tranzactii fiscale;
- Irigatii ;
- Tratarea apelor uzate;
- Instalatia de filtrare a apei (de ex. osmoza inversa si ultrafiltrare) ;
- Aplicatii de apa industrială.



## **Modul de operare**

Principiul de masurare al debitului este bazat pe legea inductiei electromagnetice a lui Faraday conform careia senzorul converteste debitul intr-o tensiune electrica proportionala cu viteza acestuia.

## **Integrarea**

Debitmetrul este alcatuit dintr-un senzor de debit si un transmiter SITRANS F M MAG 5000, MAG 6000 sau MAG 6000 I.

Conceptul de comunicare flexibila USM II simplifica integrarea si updatarea la o gama larga de sisteme, de exemplu, HART, DeviceNet, PROFIBUS DP si PA, FOUNDATION Fieldbus H1, Modbus RTU/RS 485.

## Specificatii tehnice

<b>Caracteristici produs</b>	MAG 5100 W (7ME6520)
<b>Liner</b>	EPDM sau NBR – in principal pentru piata europeana Ebonita – in principal pentru pietele non-europene
<b>Dimensiunea nominala si design-ul</b>	Senzor conic (DN15...300) Senzor integral (DN350...1200)
<b>Principiu de masurare</b> Frecventa de excitatie (retea de alimentare - 50/60 Hz)	Inductie electromagnetica DN 15 ... 65 (½" ... 2½"): 12.5 Hz/15 Hz DN 80 ... 150 (3" ... 6"): 6.25 Hz/7.5 Hz DN 200 ... 300 (8" ... 12"): 3.125 Hz/3.75 Hz DN 350...1200 (14"...48"): 1.5625 Hz/1.875 Hz
<b>Conectarea la proces</b> Cu flansa EN 1092-1  ANSI B16.5  AWWA C-207 AS4087	PN 10 (145 psi) : DN 200 ... 300 (8" ... 12") Flansa neteda PN 10 (145 psi): DN 350 ... 1200 (14" ... 48") Flansa cu umar PN 16 (232 psi): DN 50 ... 300 (2" ... 12") Flansa neteda PN 16 (232 psi): DN 350 ... 1200 (14" ... 48") Flansa cu umar PN 40 (580 psi): DN 15 ... 40 (½" ... 1½") Flansa neteda Class 150: ½" ... 12" fata neteda; 14" ... 24" raised face Class D: 28" ... 48", fata neteda PN 16 (DN 50 ... 1200), (2" ... 48") 16 bar (232 psi)
<b>Conditii de functionare</b> Temperatura ambientala Senzor Cu transmiter MAG 5000/6000 montaj compact Presiune de lucru (Abs) [abs. bar] (scade odata cu cresterea temperaturii de lucru)	-40 ... +70 °C -20 ... +60 °C  DN 15 ... 40 (½" ... 1½") : 0.01 ... 40 bar DN 50 ... 300 (2" ... 12") : 0.03 ... 20 bar DN 350 ... 1200 (14" ... 48") : 0.01 ... 16 bar
<b>Grad protectie</b> Standard  Optional	IP67 to EN 60529/NEMA 4X/6 (1 mH2O pentru 30 min) IP68 to EN 60529/NEMA 6P (10 mH2O continuu)
<b>Caderea de presiune</b>	DN 15 and 25 (½" and 1") : Max. 20 mbar la 1 m/s.

	DN 40 ... 300 (1½" ... 12"): Max 25 mbar la 3 m/s DN 350 ... 1200 (14" ... 48"): nesemnificativ
<b>Presiune de test</b>	1.5 x PN (acolo unde este cazul) FM Fire Service: 2 x PN
<b>Sarcina mecanica (vibratii)</b>	18 ... 1000 Hz aleator in orice directive x,y,z, timp de 2 ore conform EN 60068-2-36 Senzor: 3,17 grms Senzor cu transmitter MAG 5000/6000 montaj compact : 3.17 grms Senzor cu transmitter Mag 6000 I montaj compact : 1.14 grms
<b>Conditii mediu</b> Temperatura mediu masura NBR EPDM EPDM/NBR (MI-001)	-10 ... +70 °C -10 ... +70 °C 0.1 ... 30 °C
<b>EMC</b>	2004/108/EC
<b>Design</b> Material Carcasa si flanse  Teava de masura Electrod Electrod impamantare Cutia de borne	Otel carbon, acoperit anticoroziune cu vopsea epoxidica (min. 150 µm) Categoria coroziva C4, conform ISO 12944-2 Inox AISI 304/1.4301 Hastelloy C Hastelloy C Fibra de sticla armata cu poliamida
<b>Certificari si autorizatii</b> Calibrare Calibrare standard Tranzactii fiscale (doar impreuna cu MAG 6000 CT)  Aprobari pentru apa potabila	punctul de zero, 2 x 25 % si 2 x 90 % aprobare OIML R 49 pentru apa rece : DN 50 ... 300 (2" ... 12") Apa rece MI-001 (EU): DN 50 ... 300 (2" ... 12") PTB K7.2: Masurarea apei reci DN 50-300 (comanda speciala)  Liner EPDM WRAS (WRc, BS6920 apa rece, GB) ACS (F), DVGW W270 (D) Belgaqua (B)
Alte aprobari	MCERTS Conform PED: toate flansele EN1092-1 clasa ANSI 150 (< DN 300 (<12")) – 97/23/EC4) CRN (DN 50 - DN 1200 (2" ... 48")) CSA Clasa I, Div 2

## MAG 5100 W (7ME6520) cu MAG 6000 CT MI-001

Programul MAG 5100 W CT este aprobat conform standardului de masurare a apei reci OIML R 49. Incepand cu 01.11.2006 directiva de masurare a apei este aprobata, ceea ce inseamna ca toate echipamentele de masurare a apei pot fi vandute in UE daca au eticheta MI-001.

Produsele MAG 5100 W MI-001 cu diametrele DN50...300 verificate si etichetate au aprobare Clasa II conform directivei 2004/22.EC al Parlamentului European si a Consiliului European din 31.03.2004 al referitoare la instrumentele de masurare (MID), Anexa MI-001. Certificarea MID este obtinuta ca un modul de aprobare B+D conform directivei mentionate mai sus.

Modulul B: Omologare de tip conform OIML R 49

Module : Aprobare pentru asigurarea calitatii pentru productie.

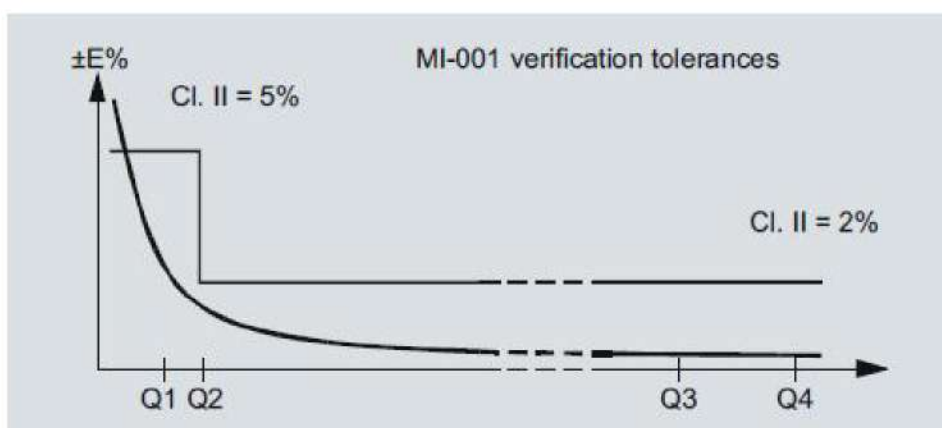

Produse MAG5100W MI-001 verificate si etichetate la un Q3 dat si Q3/Q4=1.25 si Q2/Q1=1.6

Order code: P11	DN 50 (2")	DN 65 (2½")	DN 80 (3")	DN 100 (4")	DN 125 (5")	DN 150 (6")	DN 200 (8")	DN 250 (10")	DN 300 (12")
JR Q3/Q1	25	25	25	25	25	25	25	25	25
Q4 [m³/h]	20	31.25	50	78.75	125	200	312.5	500	787.5
Q3 [m³/h]	16	25	40	63	100	160	250	400	630
Q2 [m³/h]	1.02	1.6	2.8	4.03	6.4	10.24	16	25.6	40.32
Q1 [m³/h]	0.64	1.00	1.60	2.52	4.0	6.4	10.0	16.0	25.2

Order code: P12	DN 50 (2")	DN 65 (2½")	DN 80 (3")	DN 100 (4")	DN 125 (5")	DN 150 (6")	DN 200 (8")	DN 250 (10")	DN 300 (12")
JR Q3/Q1	63	63	63	63	63	63	63	63	63
Q4 [m³/h]	20	31.25	50	78.75	125	200	312.5	500	787.5
Q3 [m³/h]	16	25	40	63	100	160	250	400	630
Q2 [m³/h]	0.41	0.63	1.02	1.6	2.54	4.06	6.36	10.2	16.0
Q1 [m³/h]	0.25	0.40	0.63	1.00	1.60	2.54	3.97	6.36	10.0

Order code: P13	DN 50 (2")	DN 65 (2½")	DN 80 (3")	DN 100 (4")	DN 125 (5")	DN 150 (6")	DN 200 (8")	DN 250 (10")	DN 300 (12")
JR Q3/Q1	80	80	80	80	80	80	80	80	80
Q4 [m³/h]	20	31.25	50	78.75	125	200	312.5	500	787.5
Q3 [m³/h]	16	25	40	63	100	160	250	400	630
Q2 [m³/h]	0.32	0.50	0.80	1.20	2.00	3.20	5.0	8.0	12.8
Q1 [m³/h]	0.20	0.31	0.50	0.75	1.25	2.00	3.13	5.0	7.90

Order code: P14	DN 50 (2")	DN 65 (2½")	DN 80 (3")	DN 100 (4")	DN 125 (5")	DN 150 (6")	DN 200 (8")	DN 250 (10")	DN 300 (12")
JR Q3/Q1	160	160	160	160	160	160	160	160	160
Q4 [m³/h]	50	78.75	125	200	312.5	500	787.5	1250	2000
Q3 [m³/h]	40	63	100	160	250	400	630	1000	1600
Q2 [m³/h]	0.40	0.63	1.00	1.60	2.50	4.00	6.3	10.0	16.0
Q1 [m³/h]	0.25	0.39	0.63	1.00	1.56	2.50	3.94	6.3	10.0

  

Order code: P17	DN 50 (2")	DN 65 (2½")	DN 80 (3")	DN 100 (4")	DN 125 (5")	DN 150 (6")	DN 200 (8")	DN 250 (10")	DN 300 (12")
JR Q3/Q1	200	200	200	200	200	200	200	200	200
Q4 [m³/h]	50	78.75	125	200	312.5	500	787.5	1250	2000
Q3 [m³/h]	40	63	100	160	250	400	630	1000	1600
Q2 [m³/h]	0.32	0.50	0.80	1.28	2.00	3.20	5.0	8.0	12.8
Q1 [m³/h]	0.20	0.32	0.50	0.80	1.25	2.00	3.15	5.0	8.0

  

Order code: P18	DN 50 (2")	DN 65 (2½")	DN 80 (3")	DN 100 (4")	DN 125 (5")	DN 150 (6")	DN 200 (8")	DN 250 (10")	DN 300 (12")
JR Q3/Q1	250	250	250	250	250	250	250	250	250
Q4 [m³/h]	50	78.75	125	200	312.5	500	787.5	1250	2000
Q3 [m³/h]	40	63	100	160	250	400	630	1000	1600
Q2 [m³/h]	0.26	0.40	0.64	1.02	1.60	2.56	4.0	6.4	10.24
Q1 [m³/h]	0.16	0.25	0.40	0.64	1.00	1.60	2.52	4.0	6.4

## Dimensiuni de gabarit

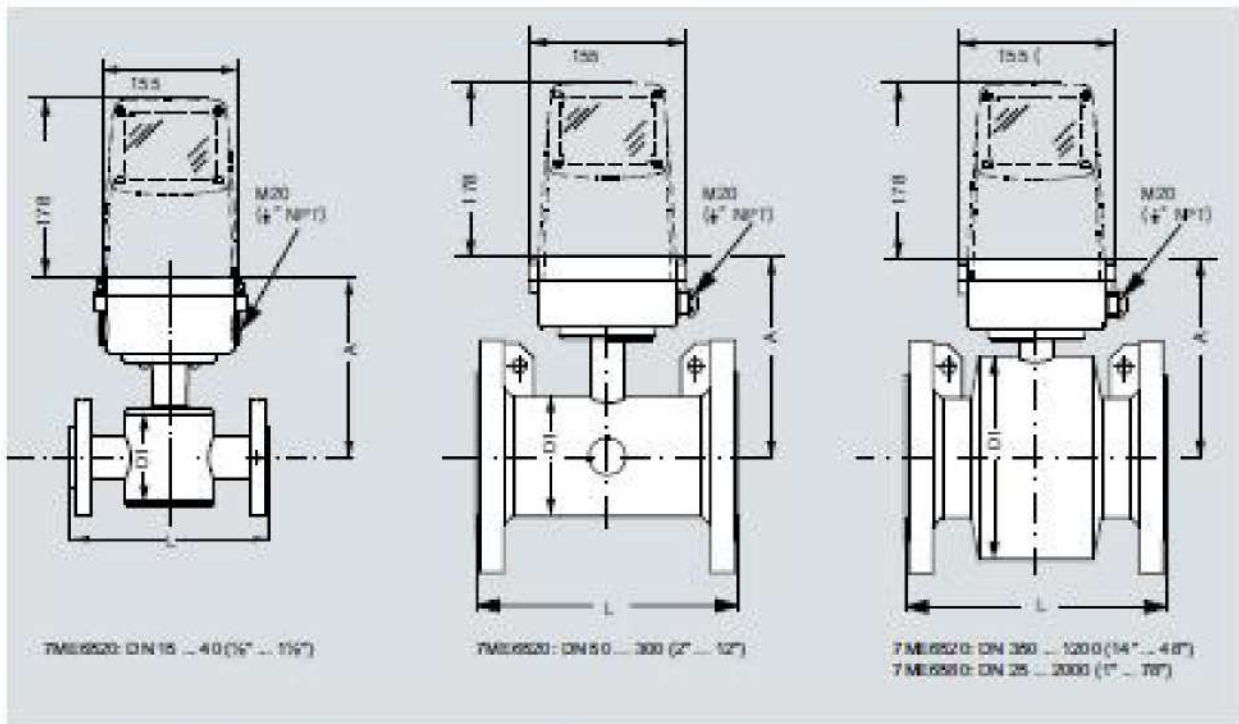

Nominal size	7ME520 NBR or EPDM liner					7ME520 Ebonite liner					
	A	D1	A	D1	L	A	D1	A	D1	L	
[mm] [Inch]	[mm] [Inch]	[mm] [Inch]	[mm] [Inch]	[mm] [Inch]	[mm] [Inch]	[mm] [Inch]	[mm] [Inch]	[mm] [Inch]	[mm] [Inch]	[mm] [Inch]	
15	1/2	177	7.0	77	3.0	-	-	104	4.09	200	7.9
25	1	187	7.4	95	3.8	187	7.4	104	4.09	200	7.9
40	1 1/2	202	8.0	127	5.0	197	7.8	124	4.88	200	7.9
50	2	188	7.4	76	3.0	205	8.1	130	5.17	200	7.9
65	2 1/2	194	7.6	89	3.5	212	8.3	154	6.06	200	7.9
80	3	200	7.9	102	4.0	222	8.7	174	6.85	200	7.9
100	4	207	8.1	114	4.5	242	9.5	214	8.43	250	9.8
125	5	217	8.5	140	5.5	255	10.0	239	9.41	250	9.8
150	6	232	9.1	168	6.6	275	10.9	262	11.1	300	11.8
200	8	257	10.1	219	8.6	304	12.0	338	13.31	350	13.8
250	10	284	11.2	273	10.8	332	13.1	369	15.47	450	17.7
300	12	310	12.2	324	12.8	357	14.1	444	17.76	500	19.7
350	14	382	15.0	451	17.8	362	14.3	502	19.78	550	21.7
400	16	407	16.0	502	19.8	387	15.2	563	22.16	600	23.6
450	18	436	17.2	553	22.2	418	16.5	614	24.17	600	23.6
500	20	483	18.2	614	24.2	443	17.4	715	28.15	600	23.6
600	24	514	20.2	715	28.2	494	19.4	816	32.13	600	23.6
700	28	564	22.2	816	32.1	544	21.4	869	34.21	700	27.6
750	30	591	23.3	869	34.2	571	22.5	927	36.5	750	29.5
800	32	616	24.3	927	36.5	606	23.9	1032	40.63	800	31.5
900	36	683	26.1	1032	40.6	653	25.7	1136	44.72	900	36.4
1000	40	714	28.1	1136	44.7	704	27.7	1136	44.72	1000	39.4
1200	48	786	30.1	1238	48.7	756	29.7	1348	53.07	1100	43.3
1400	54	-	-	-	-	810	31.9	1575	62.94	1200	47.2
1500	60	-	-	-	-	925	36.4	1672	66.23	1400	55.1
1600	66	-	-	-	-	972	38.2	1915	75.39	1500	59.1
1800	72	-	-	-	-	1025	40.4	1974	77.72	1600	63
1800	72	-	-	-	-	1123	44.2	2174	86.59	1800	70.9
2000	78	-	-	-	-	1223	48.1	-	-	2000	78.7

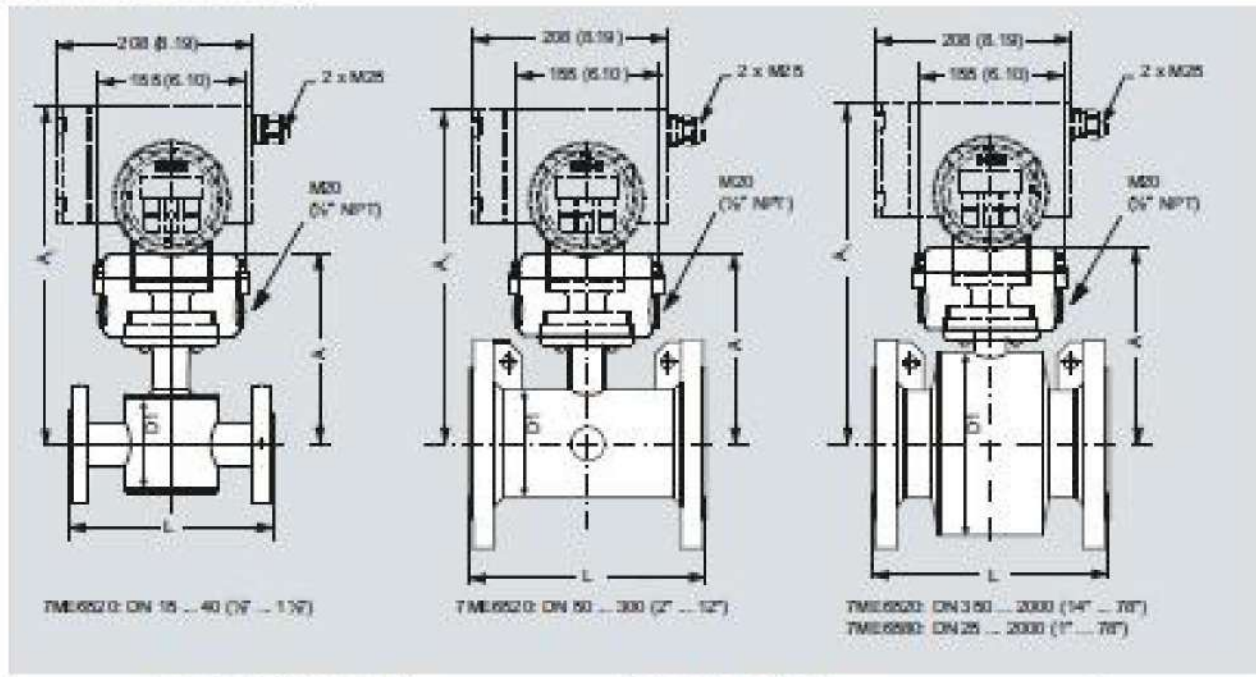

Nominal size	rMEesso NBR or EPDM liner						rMEesso Ebonite liner						L	
	A	A1	D1		A	A1	D1							
[mm] [Inch]	[mm] [Inch]	[mm] [Inch]	[mm] [Inch]	[mm] [Inch]	[mm] [Inch]	[mm] [Inch]	[mm] [Inch]	[mm] [Inch]	[mm] [Inch]	[mm] [Inch]	[mm] [Inch]	[mm] [Inch]	[mm] [Inch]	
15 1/2	177	7.0	331	13.0	77	3.0	-	341	13.4	104	4.09	200	7.9	
25 1	187	7.4	341	13.4	96	3.8	187	7.4	351	13.8	104	4.09	200	7.9
40 1 1/2	202	8.0	356	14.0	127	5.0	197	7.8	359	14.1	124	4.88	200	7.9
50 2	188	7.4	342	13.5	76	3.0	205	8.1	366	14.4	139	5.47	200	7.9
65 2 1/2	194	7.6	348	13.7	89	3.5	212	8.3	376	14.8	154	6.06	200	7.9
80 3	200	7.9	354	14.0	102	4.0	222	8.7	396	15.6	174	6.85	200	7.9
100 4	227	8.1	381	14.2	114	4.5	242	9.5	409	16.1	214	8.43	250	9.8
125 5	217	8.5	371	14.6	140	5.5	255	10.0	430	16.9	239	9.41	250	9.8
150 6	232	9.1	386	15.2	168	6.6	276	10.9	458	18.0	282	11.1	300	11.8
200 8	257	10.1	411	16.2	219	8.6	304	12.0	486	19.1	338	13.31	350	13.8
250 10	264	11.2	438	17.2	273	10.8	332	13.1	511	20.1	393	15.47	450	17.7
300 12	310	12.2	454	18.3	324	12.8	357	14.1	516	20.3	444	17.76	500	19.7
350 14	382	15.0	536	21.1	451	17.8	382	14.3	541	21.3	502	19.76	550	21.7
400 16	407	16.0	561	22.1	502	19.8	387	15.2	572	22.5	553	22.16	600	23.6
450 18	438	17.2	592	23.3	553	22.2	418	16.5	597	23.5	614	24.17	600	23.6
500 20	463	18.2	617	24.3	614	24.2	443	17.4	648	25.5	715	28.15	600	23.6
600 24	514	20.2	668	26.3	715	28.2	494	19.4	698	27.5	816	32.13	600	23.6
700 28	564	22.2	718	28.3	816	32.1	544	21.4	725	28.5	889	34.21	700	27.6
750 30	591	23.3	745	29.3	869	34.2	571	22.5	760	29.9	927	36.5	750	29.5
800 32	616	24.3	770	30.3	927	36.5	606	23.9	807	31.8	1032	40.63	800	31.5
900 36	663	26.1	817	32.2	1032	40.6	653	25.7	858	33.8	1136	44.72	900	35.4
1000 40	714	28.1	868	34.2	1136	44.7	704	27.7	858	33.8	1136	44.72	1000	39.4
42	714	28.1	868	34.2	1136	44.7	704	27.7	904	35.6	1238	48.74	1000	39.4
44	755	30.1	919	36.2	1238	48.7	755	29.7	964	38.0	1348	53.07	1100	43.3
1200 48	820	32.3	974	38.3	1348	53.1	810	31.9	1079	42.5	1575	62.04	1200	47.2
1400 54	-	-	-	-	-	-	925	36.4	1126	44.3	1672	66.83	1400	55.1
1500 60	-	-	-	-	-	-	972	38.2	1179	46.4	1915	75.39	1500	59.1
1600 66	-	-	-	-	-	-	1025	40.4	1277	50.3	1974	77.72	1600	63.0
1800 72	-	-	-	-	-	-	1123	44.2	1377	54.2	2174	85.59	1800	70.9
3000 78	-	-	-	-	-	-	1223	48.1	-	-	-	-	2000	78.7

# Greutate

Nominal size		7MEsso NBR or EPDM liner										7MEsso Ebonite liner	
		PN 10		PN 15		PN 40		Class 150AWWA		AS		PN 15	
[mm]	[inch]	[kg]	[lbs]	[kg]	[lbs]	[kg]	[lbs]	[kg]	[lbs]	[kg]	[lbs]	[kg]	[lbs]
15	3/8	-	-	-	-	4	9	4	9	4	9	5	11
25	1	-	-	-	-	6	12	5	11	4	9	5	11
40	1 1/2	-	-	-	-	8	18	7	15	7	15	8	17
50	2	-	-	9	20	-	-	8	20	9	20	9	20
65	2 1/2	-	-	10.7	24	-	-	11	24	10.7	24	11	24
80	3	-	-	11.6	26	-	-	13	28	11.6	26	12	26
100	4	-	-	15.2	33	-	-	19	41	15.2	33	16	36
125	5	-	-	20.4	45	-	-	24	52	-	-	19	42
150	6	-	-	26	57	-	-	29	64	26	57	27	60
200	8	48	106	48	106	-	-	56	124	48	106	40	88
250	10	64	141	69	152	-	-	79	174	69	152	60	132
300	12	76	167	86	189	-	-	110	243	86	189	80	176
350	14	104	229	125	274	-	-	139	307	115	254	110	242
400	16	119	263	143	314	-	-	159	351	125	277	125	275
450	18	136	299	173	381	-	-	182	400	141	311	175	386
500	20	163	359	223	491	-	-	225	495	189	418	200	440
600	24	236	519	338	744	-	-	320	704	301	664	287	633
700	28	270	595	314	692	-	-	273	602	320	704	330	728
750	30	-	-	-	-	-	-	329	725	-	-	350	794
800	32	346	763	396	873	-	-	365	804	428	944	450	992
900	36	432	951	474	1043	-	-	495	1089	519	1162	530	1168
1000	40	513	1130	500	1121	-	-	583	1282	636	1399	660	1455
	42	-	-	-	-	-	-	687	1512	-	-	-	-
	44	-	-	-	-	-	-	753	1680	-	-	1140	2513
1200	48	643	1415	665	1348	-	-	861	1896	813	1799	1160	2601
1400	54	1592	3510	-	-	-	-	-	-	-	-	1600	3628
1500	60	-	-	-	-	-	-	-	-	-	-	2460	5423
1600	66	2110	4652	-	-	-	-	-	-	-	-	2525	5566
1800	72	2560	5644	-	-	-	-	-	-	-	-	2930	6460
2000	78	3640	8025	-	-	-	-	-	-	-	-	3665	8080