

2023 V1.0

# INSTALLATION GUIDE

SERAPHIM PHOTOVOLTAIC MODULE



JIANGSU SERAPHIM PHOTOVOLTAIC SYSTEM CO. LTD.

ADDRESS: No.10, TongshunRD, Henglin Town, Wujin District,

Changzhou, China

TELEPHONE: +86-519-69699879

MAILBOX: info@seraphim-energy.com

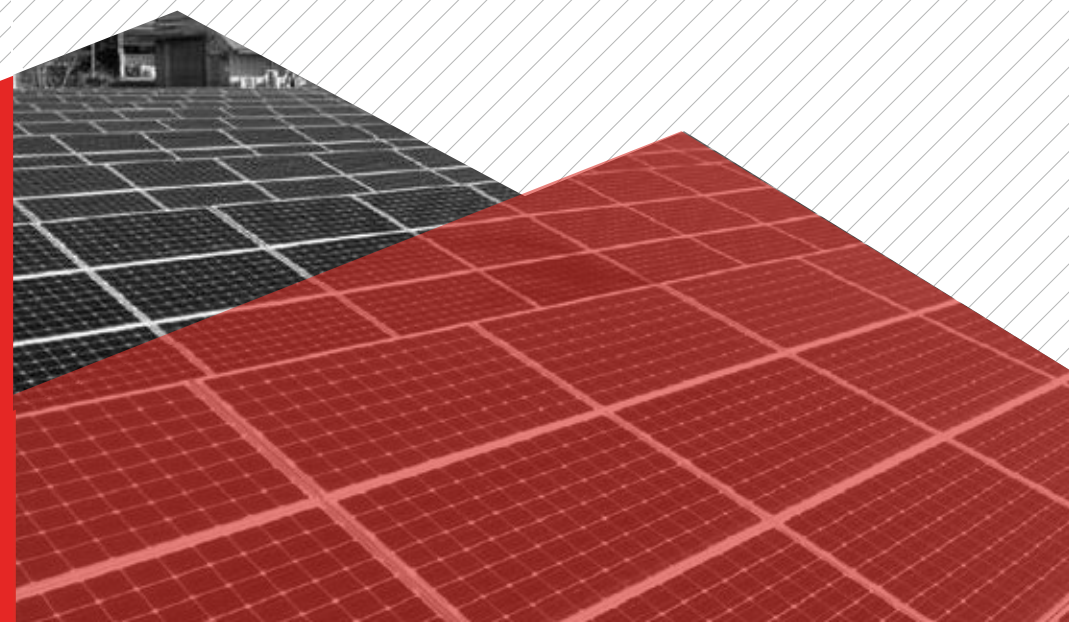

# 1 PURPOSE OF THIS GUIDE

Thanks for choosing Seraphim Photovoltaic Modules (hereafter referred to as “PV Module” ), This Guide is to give information on how to apply Seraphim PVmodules properly.

Installers must read and understand this Guide prior to installation. For any questions, please contact our technical department (technic@seraphim-energy.com) for further information. Installers should follow all safety precautions described in this Guide as well as local codes when installing a module.

Keep this Guide in a safe place for future reference (care and maintenance) and in case of sale or disposal of the PV modules.

## 1.1 APPLICABLE PRODUCTS

This document is applicable to the series of PV modules as listed below:

Type 1	SRP-XXX-6PA, SRP-XXX-6PA-HV, SRP-XXX-6MA, SRP-XXX-6MA-HV
Type 2	SRP-XXX-6PB, SRP-XXX-6PB-HV, SRP-XXX-6MB, SRP-XXX-6MB-HV
Type 3	SRP-XXX-BPZ, SRP-XXX-BPZ-HV, SRP-XXX-BMZ, SRP-XXX-BMZ-HV, SRP-XXX-BTZ-HV
Type 4	SRP-XXX-BPA, SRP-XXX-BPA-HV, SRP-XXX-BMA, SRP-XXX-BMA-HV, SRP-XXX-BTA-HV
Type 5	SRP-XXX-BPB, SRP-XXX-BPB-HV, SRP-XXX-BMB, SRP-XXX-BMB-HV, SRP-XXX-BTB-HV
Type 6	SRP-XXX-BPC, SRP-XXX-BPC-HV, SRP-XXX-BMC, SRP-XXX-BMC-HV, SRP-XXX-BTC-HV
Type 7	SRP-XXX-BMD, SRP-XXX-BMD-HV, SRP-XXX-BTD-HV

NOTE : - HV: Modules with 1500V ; XXX : Module power

# 2 SAFETY

## 2.1 GENERAL SAFETY

• The PV modules are qualified for application class A, which may be used in systems operating at greater than 50 V DC or 240 W, where general contact access is anticipated. PV modules qualified for safety through this part of IEC 61730 and IEC 61730-2 and within this application class are considered to meet the requirements for safety class II.

- The PV modules shall be properly grounded in accordance with the instructions in this Guide or the requirements of the National Electrical Code.
- Installing PV modules requires specialized skills and knowledge. Installation should only be performed by qualified personnel, electrical connections requires a licensed electrician , where applicable according to local code and law (i.e. the NEC for the USA and CEC for Canada).
- Installers should assume all risks of injury that might occur during installation, including, but not limited to, the risk of electric shock.
- One single PV module may generate more than 30V DC when exposed to direct sunlight. Access to a DC voltage of 30V or more is potentially hazardous.
- PV modules convert light energy to DC electrical energy, which are designed for outdoor use. PV modules can be mounted onto ground, rooftop, vehicles or boats etc. The proper design of support structures lies within responsibility of the system designers and installers.
- Do not use mirrors or other magnifiers to concentrate sunlight onto the PV modules.
- When installing the PV modules, abide to all local, regional and national statutory regulations. Obtain a building permit if necessary.
- Only use equipment, connectors, wiring and support frames compatible with the PV modules.
- Do not clean the modules with chemicals.

## 2.2 HANDLING SAFETY

- Do not lift the PV module by grasping the module’ s junction box or electrical leads.
- Do not stand or step on the PV modules or place heavy objects onto it.
- Do not drop the PV module or allow objects to fall on the PV module.
- Do handle with care when move, transport and install the PV modules.
- Do not attempt to disassemble the PV modules, and do not remove any attached nameplates or components from the PV modules.
- Do not apply paint or adhesive to the PV module top surface.
- Do not scratch or hit the back sheet.

- Do not drill holes in the frame. This may reduce the frame mechanical strength and cause crack cells due to vibration.
- Do not break the anodized coating of the frame (except for grounding connection), this may cause corrosion of the frame.
- Do not use PV modules with broken glass or torn back sheet which has danger of electrical shock.
- Do not handle panels in wet condition unless has appropriate protection.
- Do not expose PV module to sunlight until installation to avoid unnecessary degradation.
- During all the transportation, please make sure there is no strenuous vibration on module. Because it may cause cell micro crack or damage the module.

## 2.3 INSTALLATION SAFETY

- Installation shall be in conformity with IEC standard, Safety Standard for Electrical Installations.
- Do not disconnect under load.
- Do not touch conductive parts of PV modules, such as terminals which can result in burns, sparks and lethal shock whether or not the PV module is connected.
- Do not touch the PV module unnecessarily during installation.
- Do not work in the rain, snow or windy conditions.
- Do not expose the artificially sunlight to PV modules. Completely cover the PV module with an opaque material during installation to prevent electricity from being generated.
- Do not wear metallic rings, watchbands, ear, nose, lip rings or other metallic objects while installing or troubleshooting.
- Only use insulated tools that are qualified for working on electrical installations.
- Follow the safety regulations for all other system components, including wires and cables, connectors, charging regulators, inverters, storage batteries, rechargeable batteries, etc.

- Under normal outdoor conditions the current and voltage generated will differ from those listed on the datasheet. When design systems, current and short-circuit current should be multiplied by a factor of 1.25 to determine components ratings.
- Only use connectors compatible with the PV module connectors. Removing the connectors without prior authorization will invalidate the warranty.
- Do not dismantle installed modules to another project, which may invalidate the warranty.
- Do not install modules within 50m of the shoreline

## 2.4 FIRE SAFETY

- The fire rating of this module is valid only this Guide is followed.
- Consult your local authority for Guidelines and requirements for building or structural fire safety.
- Do not use PV modules near equipment or in places where flammable gases may be generated.
- Follow local codes and laws when install the modules

# 3 PRODUCT IDENTIFICATION

Each module has three Barcode stickers which have the same unique serial No. of each module and one label sticker:

Barcode 1: Laminated into PV modules.

Barcode 2: Stick on the backside of PV modules.

Barcode 3: Stick on the middle location of long Frame side.

Label: Stick on the backside of PV modules, contains characteristics parameters of the PV modules.

Check the serial No. in the barcode with the packing list when unpacking. Provide PV module serial No. when you need support from SERAPHIM on particular PV modules.

## 4 MECHANICAL INSTALLATION

### 4.1 GENERAL INSTALLATION PRINCIPLE

- Module can be installed in both landscape and portrait modes <sup>[1]</sup>
- It is recommended to install the same size and the same type of module in one PV array.
- The PV modules shall be installed high enough to keep it away from potential shading, flying sands, snow and water.
- It is recommended to install the PV modules 30cm away from the ground to make sure ventilation.
- Appropriate installation structures shall be chosen to meet required mechanical load.
- It is recommended to install the PV modules with minimum angle of 10 degree to make the dust easily to be washed off.
- It is recommended to keep minimum 10mm gap between PV modules for thermal expansion of materials.
- Install PV modules appropriately according to corresponding mechanical load need.

### 4.2 LOCATION AND ANGLE SELECTION

It is recommended to install PV modules where has excellent sunlight resources. In the Northern Hemisphere, the module should typically face south, and in the Southern Hemisphere, the modules should typically face north. The most optimistic installation angle varies according to different latitudes and longitudes; please consult experts with appropriate knowledge background when determining the installation locations and angles.

When choosing a site, avoid trees, buildings or obstructions, which could cast shadows on the solar photovoltaic modules. Shading causes hotspot and loss of output, even though the factory fitted bypass diodes of the PV module will minimize such effect.

Do not install the PV module near naked flame or flammable materials.

Do not install the PV module in a location where it would be immersed in water or constantly exposed to water from a sprinkler or fountain etc.

### 4.3 SCREW INSTALLATION

Each PV module has 8 mounting holes (shown as drawing 1-1). The downward mechanical load resistance of module would be different according to the installation holes used (shown as table 1-1). Please use 8 of them to secure the modules to support structure. The module frame must be attached to a mounting rail using M8 corrosion-proof screws together with spring washers and flat washers in eight symmetrical locations on the PV module. The applied torque should be big enough to fix it steadily. The reference torque value for M8 screw is 16~20N\*m.

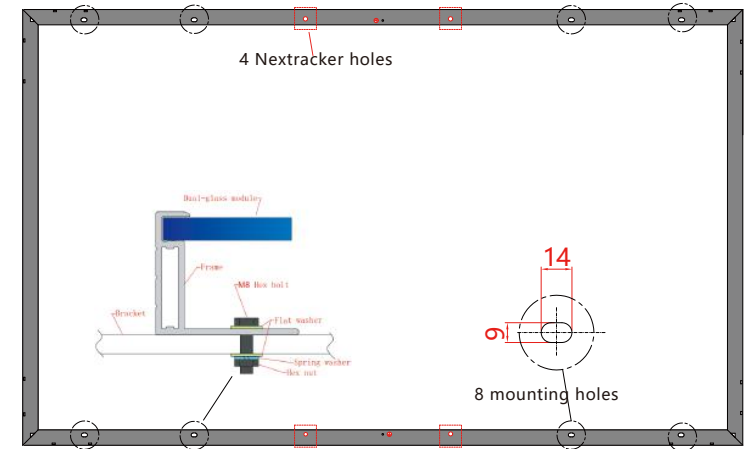

**DRAWING 1-1**

INSTALLED HOLES USED	MECHANICAL LOAD
8 Installation Holes (not suitable for 210 and 182-BMA module)	5400Pa
4 Installation Holes ( Inner ones )	2400Pa
4 Nextracker Holes ( only for 72 type module )	2400Pa

**TABLE 1-1**

For 210 and 182-BMA modules, four mounting holes are used for the frame in the standard industry, so as to facilitate customer installation. We used four mounting holes in the frame of 210 and 182-BMA modules (shown on drawing 1-2).

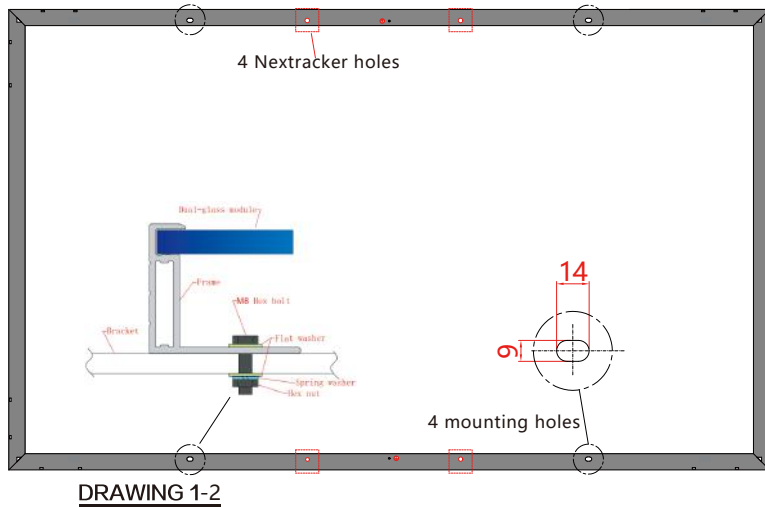

INSTALLED HOLES USED	MECHANICAL LOAD
4 Installation Holes (only for 210 and 182-BMA module)	5400Pa
4 Nextrack Holes (only for 72 type module)	2400Pa

**TABLE 1-2**

## 4.4 CLAMP INSTALLATION

The modules can be fixed on both the long and the short side of the module within the constraints shown in drawing2 and drawing3, using a minimum of four clamps. The modules are built to withstand a downward force of up to 5400 Pa (550 kg/m<sup>2</sup>) or 2400 Pa (244 kg/m<sup>2</sup>) according to where they are clamped (shown as table2 and table3), Site-specific loads such as wind or snow which may exert forces in a different way need to be taken into consideration to ensure this limit is not exceeded for each respective mounting option.

### 4.4.1 .Install module with clamps at long sides of frames

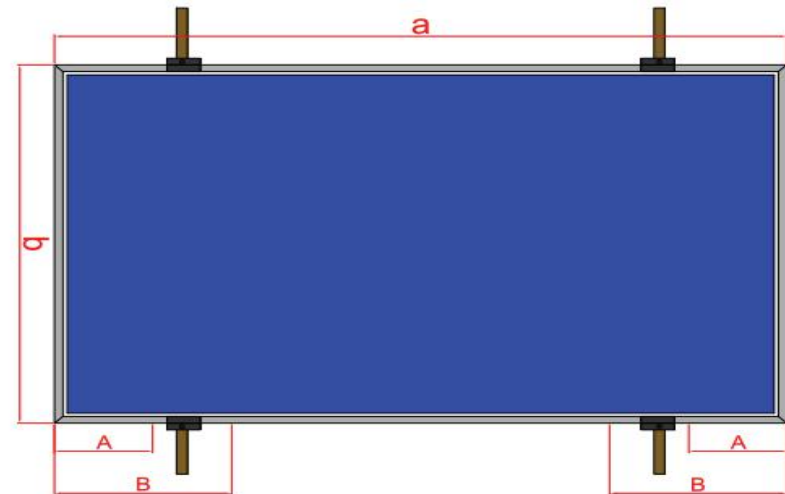

**DRAWING 2 -1**

module type	a(mm)	b(mm)	Clamp length	A(mm)	B(mm)	Loads (Pa)	
Type1	1985/ 1970/1956	992/1002	≥50mm	380	580	5400	
				50	580	2400	
Type2	1665/ 1650/1640	992/1002	≥50mm	300	500	5400	
				50	500	2400	
Type3	2180/2465	1002/1134	≥50mm	380/450	580/650	5400	
				50/100	580/650	2400	
Type4	2288/2256/ 2279/2278/ 2094	1134/1133/ 1134/1134/ 1038	≥50mm	380	580	5400	
				380	580	5400	
	1996/2015	992/1002	≥50mm	380	580	5400	
				50	580	2400	
Type5	1755/1909	1038/1134	≥50mm	300	500	5400	
				300	500	5400	
				50	480	2400	
Type6	1852	1002	≥50mm	300	500	5400	
				50	500	2400	
Type7	35 Frame	1707/1730	1133/1134	≥50mm	300	500	5400
	28 Frame	1722	1134	≥50mm	300	500	5400

TABLE 2-1

For 210 and 182-BMA modules, four mounting holes are used for the frame in the standard industry, so as to facilitate customer installation. We used four mounting holes in the frame of the 210 and 182-BMA modules.

In addition, to ensure the reliability of the 210 plate assembly against mechanical loads, we used three mounting brackets, as shown in Drawing 2-2.

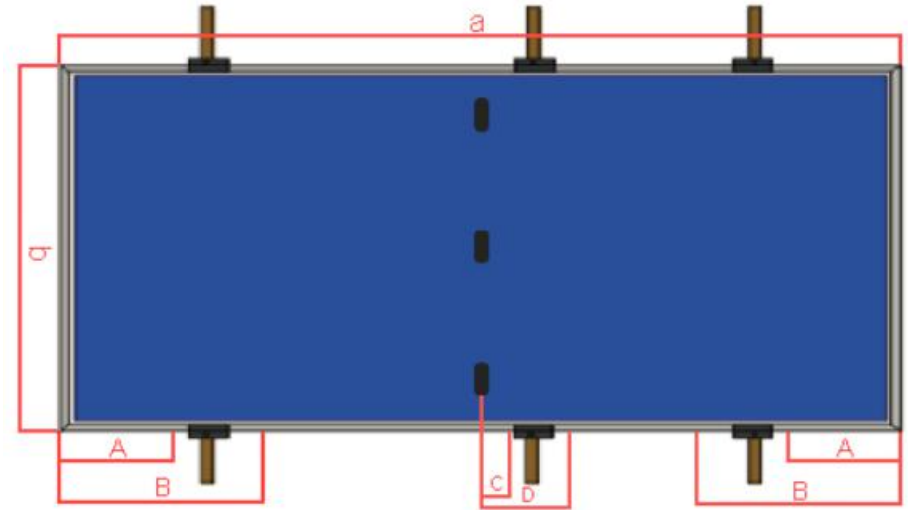

DRAWING 2-2

Module type	a(mm)	b(mm)	Clamp length	A(mm)	B(mm)	C(mm)	D(mm)	Loads (Pa)
Type5	2172	1303	≥80mm	250	450	50	100	5400
Type6	2384	1303	≥80mm	280	480	50	100	5400

TABLE 2-2

#### 4.4.2. Install module with clamps at short sides of frames

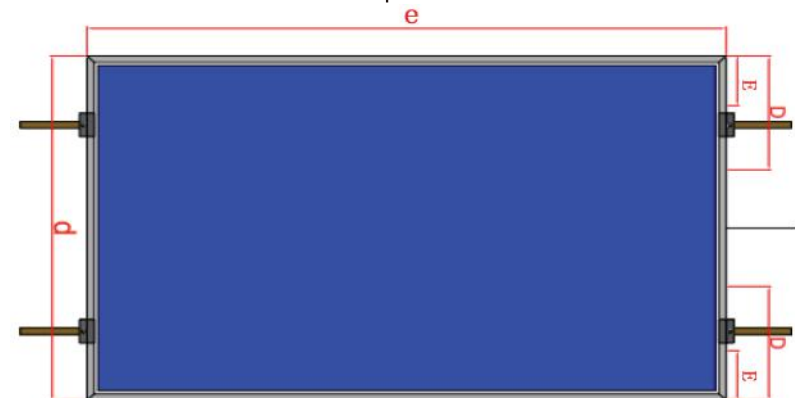

DRAWING 3

TYPE	e(mm)	d(mm)	Clamps length	E(mm)	D(mm)	Loads (Pa)	
Type1	1985/ 1970/1956	992/1002	≥50mm	50	248	2400	
Type2	1665/ 1650/1640	992/1002	≥50mm	50	248	2400	
Type3	2180	1002	≥50mm	50	248	2400	
Type4	2288/2256/ 2279/2278	1134/1133/ 1134/1134	≥50mm	60	280	2400	
	1996/2015/ 2094	992/1002/ 1038		50	248	2400	
Type5	1755/1909/ 1674/1690	1038/1134/ 992/1002	≥50mm	50	248	2400	
	2172	1303	≥80mm	60	280	2400	
Type6	1852	1002	≥50mm	50	248	2400	
	2384	1303	≥80mm	60	280	2400	
Type7	35 Frame	1707/1730	1133/1134	≥50mm	50	248	2400
	28 Frame	1722	1134	≥50mm	50	248	2400

TABLE 3

## 4.5 ELECTRICAL INSTALLATION



WARNING Electrical Hazard

This module produces electricity when exposed to light. Follow all applicable electrical safety precautions.

- ONLY qualified personnel can install or perform maintenance work on these PV modules.
- BE AWARE of dangerous high DC voltage when connecting module.
- DO NOT damage or scratch the rear surface of the module.
- DO NOT handle or install module when they are wet.

The wiring components shall be compatible with the PV modules.

The PV modules connected in serial shall have similar current. The Voc of one PV string shall no higher than the maximum system voltage(make reference to the maximum system voltage marked on label), the Voc temperature coefficient

feature and the extreme low temperature of installation location must be taken into consideration when calculate the Voc of the PV string .

The PV modules connected in parallel shall have similar Voltage. The Isc temperature coefficient feature and the extreme high temperature of installation location must be taken into consideration when calculate the Isc of the PV array.

Please refer to local regulations to determine the system wires size, type and temperature.

The cross-sectional area and cable connector capacity must satisfy the maximum short-circuit of PV system (For a single component, we recommended the cross-sectional area of cables is 4mm<sup>2</sup> and the the rated current of connectors is more than 15A), otherwise cables and connectors will become overheating for large current. Please pay attention: the temperature limit of cables is 85 ° C and the temperature limit of connector is 105°C

A qualified system designer or integrator should always be consulted.

Building permits, inspections and approvals by the local utility are generally required.

Before installation, make sure that the connector is well protected and there should be no foreign matter such as soil, sand and gravel in the connector. If any, it must be cleaned before installation. If the connector is damaged or deformed, the connector must be replaced before use; if there is no spare connector, please contact seraphim in time.

Remark : If conversion cable is needed, see attachment1 for details.

## 4.6 GROUNDING

Where common grounding hardware (nuts, bolts, star washers, spilt-ring lock washers, flat washers and the like) is used to attach a listed grounding/bonding device, the attachment must be made in conformance with the grounding device manufacturer' s instructions.

For grounding and bonding requirements, please refer to regional and national safety and electricity standards. If grounding is required, use a recommended connector type, or an equivalent, for the grounding wire.

If grounding is required, the grounding wire must be properly fastened to the module frame to assure adequate electrical connection (grounding hole shown as drawing 4).

When system operates in high humidity and high temperature circumstances, transformer-Based inverter allowing system negative grounding is highly recommended to achieve mitigating risk of higher power degradation rate.

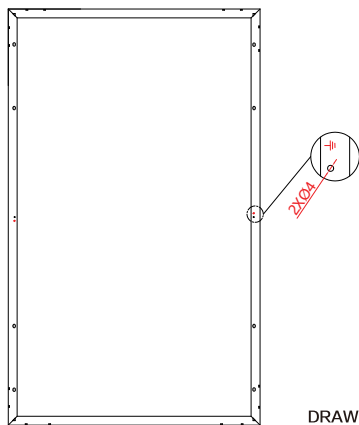

DRAWING 4

## 5 MAINTENANCE

Clean the glass surface of the module regularly with clean water and a soft sponge or cloth. A mild, non-abrasive cleaning agent may be used to remove stubborn dirt. Water with high mineral content is not recommended to clean the module.

Check the electrical, grounding and mechanical connections every six months to verify that they are clean, secure, undamaged and free of corrosion.

If any problem arises, consult a professional for suggestions.

Caution: observe the maintenance instructions for all components used in the system, such as support frames, charging regulators, inverters, batteries etc.

## 6 PARAMETERS

The parameters may be updated time to time, accurate parameters please check on our website: <http://www.seraphim-energy.com> or email to our technical support team: [technic@seraphim-energy.com](mailto:technic@seraphim-energy.com).

Note: This version of TUV Installation Guide are effective from Nov2019 , until it is replaced by new version.

## 【1】REMARK

Module Type	Landscape installation	Portrait installation
Type1 Type2		
Type3 Type4 Type5 Type6 Type7		



## ATTACHMENT 1 INSTRUCTIONS FOR USE OF CONVERSION CABLES

### Conversion cables are required to meet any of the following conditions:

1. When the DC side input terminal of the inverter or combiner box is original MC4.
2. When the manufacturer of inverter or combiner box requires series DC input bus terminal must be MC4.

### Inspection before use:

1. Confirm the original MC4 connector of the conversion cable and compatible MC4 connector.
2. Make sure that the connector on the conversion cable is not detached or loose, and the metal core is not skewed or water stained, etc.
3. Confirm that the cable insulation layer of the conversion cable is not damaged, and the cable is not severely bent or twisted.

### Installation of conversion cable:

1. The conversion cable installation position: the positive pole of the string is the positive pole of the first component junction box cable in the string, and the negative pole is the negative pole of the last component junction box cable in the string.
2. Insert the positive pole of the string into the negative pole of the conversion cable (compatible), and connect the other positive pole of the conversion cable (original MC4) to the DC positive input terminal of the inverter or combiner box.
3. Insert the negative pole of the string into the positive pole of the conversion cable (compatible), and connect the negative pole of the conversion cable (original MC4) to the DC negative input of the inverter or combiner box.

The schematic diagram is as follows:

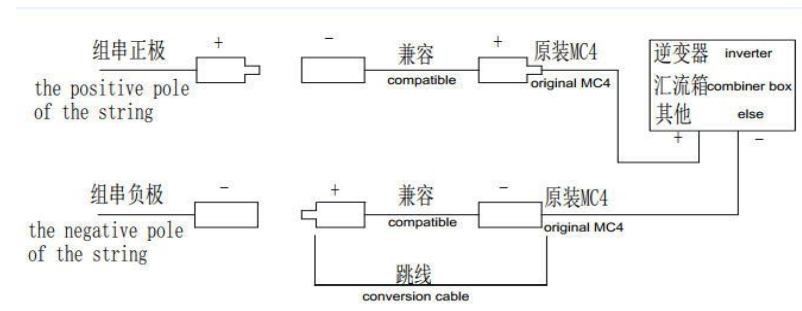

### Precautions:

1. Make sure that the polarity of the string after connection matches the polarity between the inverter or combiner box.
2. When using, install and connect strictly according to the schematic diagram, and do not reverse operation.
3. Each string on the DC side is limited to one pair of conversion cable wires, and cannot be abused, such as connecting multiple times as an extension wire.