

Product Specification of:

Medical Oxygen Sensor

Type: **M-07s**

Part Number: **410109**

Nuova ID: **E-77/0S**

RoHS compliant and SVHC free

Meets the applicable requirements of ISO 80601-2-55

Comes with CE marking. further regulatory registrations available upon request

Produced under EN ISO 13485 Quality Management System

DOCUMENT PURPOSE

The purpose of this document is to present the performance specification and key features of the sensor.

This document should be used in conjunction with the Operating Manual of the instrument and the Product Safety Data Sheet of the sensor.

KEY FEATURES

Long-life galvanic gas sensor with high signal stability at low cross sensitivity to anesthesia gases combined with superior linearity over the entire measurement range.



High Signal Stability



Superior Linearity



Wide Measurement Range



Separate Temperature Compensation Network

TECHNICAL SPECIFICATIONS

MEASUREMENT

Operating Principle:	Partial pressure electrochemical cell	
Measurement Range:	0 ... 100 Vol.%O ₂	
Initial Output Signal:	7.5 ... 13.0 mV	at dry ambient air
Response Time t ₉₀ :	< 12 s	
Signal Drift (long-term):	≤ ± 1	at ambient air
Linearity Error:	≤ ± 3	at 100 Vol.%O ₂ applied for 5 min
Zero Signal Offset:	≤ 0.3 Vol.%O ₂	at 100 Vol.%N ₂ applied for 5 min
Repeatability Error:	≤ ± 1 Vol.%O ₂	at 100 Vol.%O ₂ applied for 5 min
Influence of Gas Humidity:	- 0.03 % of signal per %rH	
Signale Temperature Compensation	NTC on sensor PCB	
Cross-Sensitivity:	fulfills DIN EN ISO 80601-2-55	

ELECTRICAL

Electrical Connector	4P4C Handset Modular Jack 4 Position (RJ11), Type AMP	
Recommended Load Resistor:	≥ 10 kOhm	

MECHANICAL

Weight:	≤ 28 g	
Material in Contact with Media:	PA, PPS, PTFE, Stainless Steel NBR	
Gas Connector:	fits for M16x1 DIN 13 or 5/8-24 UNEF	

ENVIRONMENTAL

Operating Temperature Range:	10 ... 40 °C	
Ambient Pressure Range:	700 ... 1250 hPa	
Ambient Humidity Range:	up to 100 %rH	non-condensing

LIFETIME

Expected Operating Life:	3 years	at ambient air, depending on application
Nominal Sensor Life:	500 000 Vol.%h O ₂	at ambient air, depending on application

Important Note: All characteristics are based on conditions at 25 °C, 50 %rH, 1013 hPa and a gas flow of > 2.5 L_g/min. For sensor performance data under other conditions, contact ITG.

STORAGE CONDITIONS IN UNOPENED ORIGINAL PACKAGE

Ambient Temperature Range:	15 ... 25 °C	recommended
	-20 ... 50 °C	maximum (≤ 10 h)
Ambient Pressure Range:	700 ... 1250 hPa	
Ambient Humidity Range:	50 ... 100 %rH	recommended non-condensing
	0 ... 30 %rH	maximum one week

RELATED PRODUCTS

Product	Part Number	Other Specifics
O ₂ Sensor M-07	41 00 09	-
O ₂ Sensor M-07T	47 00 12	translucent housing
O ₂ Sensor M-07S	41 01 09	different pln assignment
O ₂ Sensor M-07ST	41 02 09	translucent housing, different pln assignment

Cleaning and Disinfection

The sensor outer housing can be cleaned with a dry wipe. Do not wipe the sensor's gas entrance side. Do not use any chemical disinfectant or sanitizer on the sensor.

Poisoning

ITG sensors are designed to operate in a wide range of environments. For optimal sensor lifetime and performance it is important that exposure to high concentrations of solvent vapors is avoided during storage, installation into instruments and operation of the sensor. Do not use adhesives directly on or near the sensor as the solvents may cause stress corrosion on the plastic parts.

Intended Use

The electrochemical oxygen sensors for use in medical technology are used as accessories with a limited shelf life exclusively in conjunction with other medical products (ventilators, incubators, anesthesia machines, portable oxygen monitors, oxygen therapy devices and gas mixing units) so that they can fulfill the manufacturer's intended purpose.

The oxygen sensors measure the oxygen partial pressure in gas mixtures.

Commissioning and use is carried out exclusively by expert clinic or service personnel. Direct contact with these items occurs during installation or maintenance by trained personnel.

Stabilisation Time

When installing a new sensor refer to the instrument manual for stabilization time before calibration.

If not specified otherwise wait at least 15 minutes to ensure the sensor has stabilized in the instrument.

Calibration Interval

ITG sensors are designed to have minimal signal drift over their functional lifetime. For optimal performance and maximum measurement accuracy however they should be calibrated before each use.

If the Sensor is dropped

If a sensor is dropped, please check for visible mechanical damage of the sensor or if the sensor is leaking electrolyte. If this is the case, do not try to install the sensor into the device. Take safety precautions and immediately dispose the cell.

If the sensor shows no visible damage it should be placed in quarantine for at least 24 hours. Afterwards a follow-up check made by a two point calibration should be done.

Installation in Device

A gas tight sealing is ensured when the sensor is screwed in hand-tight. Don't use any mechanical tools to install the sensor. Using excessive force may damage the sensor.

Optimal mounting position of the sensor is when the gas sensing area faces downwards. A horizontal position is acceptable. It is not recommended to use the sensor with the gas sensing area facing upward.

Connection should be made via recommended electrical and mechanical connectors only. The specified load resistance must be taken into account. Soldering the sensor will damage it and void the warranty. Please contact ITG for further information.

Since temperature has an influence on the output signal it is not advisable to place any heat or vibration sources (i.e. electric- pumps or valves, coolers, etc.) in close proximity to the cell.

Avoid proximity of the cell to any EMC radiating units as those emit frequencies which might interfere with the sensor's electrical connection and connecting cable.

RFI/EMI Susceptibility

ITG sensors contain metal parts and might be susceptible to RFI or EMI. Before use in MRI environments please contact ITG for further information.

Disposal

At the end of the sensors lifetime the sensor should not be disposed of in normal public waste as it may contain hazardous materials and caustic electrolyte (for more information refer to the PSDS). Please contact your local authorities for environmental legislation to relevant local waste disposal.

TECHNICAL DRAWING

Sensor	ITG Part number	Color			Electrical pin assignment			
		Cap	Housing	Threaded ring	Pin 1	Pin 2	Pin 3	Pin 4
M-07S	410109	white	white	white	linked with Pin 3	plus (+)	linked with Pin 1	minus (-)

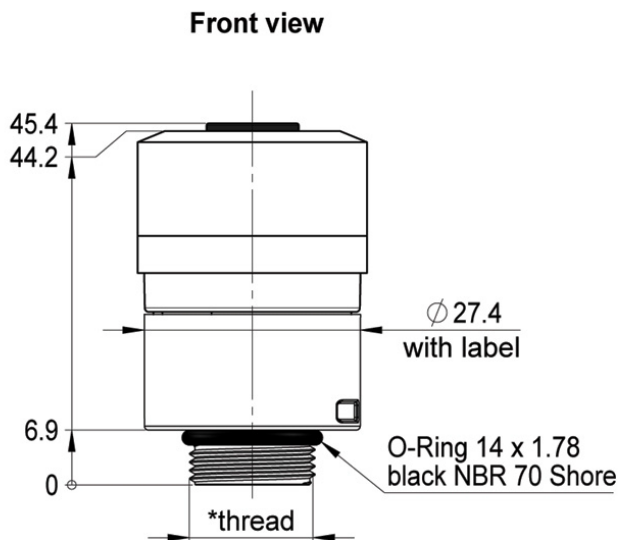
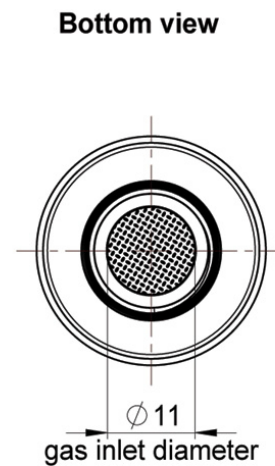
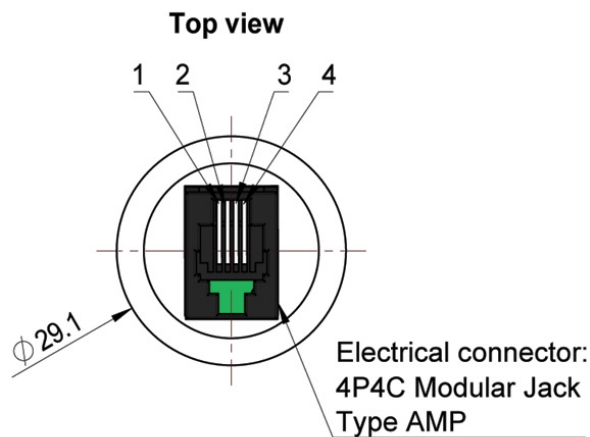

Dimension unit: mm
Dimension tolerances: linear ± 0.5 mm , diameter ± 0.3 mm

CERTIFICATE

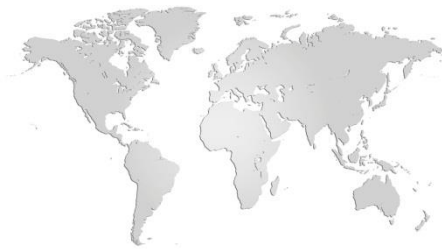

EN ISO 13485:2016 + AC:2018 + A11:2021

DEKRA Certification GmbH hereby certifies that the organization

IT Dr. Gambert GmbH

Scope of certification:

Design and development, manufacture and distribution of electro-chemical gas sensors for medical equipment

Certified location:

Hinter dem Chor 21, 23966 Wismar, Germany

has established and maintains a quality management system according to the above mentioned standard. The conformity was adduced with audit report no. 50403-Z8-00.

Certificate registration no.: 50403-21-01_EN
Validity of previous certificate: 2024-05-23

Certificate valid from: 2024-08-05
Certificate valid to: 2027-05-23

Karin Leicht
DEKRA Certification GmbH, Stuttgart, 2024-08-05



Deutsche
Akkreditierungsstelle
D-ZM-16029-08-00

EC CERTIFICATE

for the Quality Assurance System



according the Directive 93/42/EEC, Annex II excluding section (4)

As a Notified Body of the European Union, DEKRA Certification GmbH certifies, that the company
IT Dr. Gambert GmbH

Hinter dem Chor 21, 23966 Wismar, Germany

Certified location:

Hinter dem Chor 21, 23966 Wismar, Germany

applies a quality assurance system according to the Directive 93/42/EEC Annex II for the medical devices listed in the annex. The approval is based on the result of the re-certification audit report no. 50403-Z6-00, the decision dated 2018-08-31 and is only valid in connection with the successful performance of the annual surveillance audits.

This certificate is valid from 2018-09-17 to 2023-09-16

Registration No.: 50403-16-07

A handwritten signature in black ink, appearing to read 'Ruth Delbeck-Bayer', written over a horizontal line.



Ruth Delbeck-Bayer
DEKRA Certification GmbH Stuttgart; 2018-08-31
Notified Body ID-number: 0124

DEKRA Certification GmbH * Handwerkstraße 15 * D-70565 Stuttgart * www.dekra-certification.de



Benannt durch/Designated by
Zentralstelle der Länder
für Gesundheitsschutz
bei Arzneimitteln und
Medizinprodukten
www.zlg.de
ZLG-BS-295.10.02

Annex to the EC Certificate No. 50403-16-07

Valid from 2018-09-17 to 2023-09-16

Revision status of the annex: 0 dated 2018-08-31

Devices/device categories included in the certificate:

Class II a:

- Oxygen sensors
- Nitric oxide sensors



Ruth Delbeck-Bayer



Ruth Delbeck-Bayer
DEKRA Certification GmbH, Stuttgart, 2018-08-31
Notified Body ID-number: 0124

DEKRA Certification GmbH * Handwerkstraße 15 * D-70565 Stuttgart * www.dekra-certification.de

Agreement about the Extension of certificates according to MDD 93/42/EEC issued by DEKRA Certification GmbH for continuation of MDD 93/42/EEC surveillance activities, in reference to Regulation (EU) 2023/607 of the European Parliament and of the Council of 15 March 2023 amending Regulation (EU) 2017/745 as regards the transitional provision for certain medical devices

hereinafter “**Extension Agreement**”

Parties:

DEKRA Certification GmbH, having its seat in Stuttgart, Germany, hereinafter to be referred to as "DEKRA"

and

IT Dr. Gambert GmbH having its seat in Wismar, Germany, hereinafter to be referred to as Manufacturer,

Introduction:

Regulation (EU) 2023/607 of the European Parliament and of the Council of 15 March 2023 amending Regulation (EU) 2017/745 as regards the transitional provision for certain medical devices has been published on 20 March 2023 and came into force on the same day.

This Regulation (EU) 2023/607 has amended Regulation (EU) 2017/745 (from here referred to as MDR 2017/745) to now identify that under certain conditions certificates issued by notified bodies in accordance with Directive 93/42/EEC that were still valid on 26 May 2021 and that have not been withdrawn afterwards shall remain valid after the end of the period indicated on the certificate under certain conditions. Additionally, should the manufacturer intend to make use of the extension of the validity of the certificates, involvement of a notified body for continued surveillance is required.

This agreement identifies the devices and certificates for which the required conditions are met and that the manufacturer intends to make use of the options for extension of the validity of the certificates. The agreement also identifies the conditions under which DEKRA will be the notified body responsible for continued surveillance. In order for DEKRA to continue these surveillance activities the Certification Agreement in place with the manufacturer will be extended, as detailed further below.

Extension Agreement

Agreement:

Manufacturer has identified the intention to make use of the options for extension of the validity of the certificates as detailed in the amendment of the MDR 2017/745 by Regulation (EU) 2023/607.

Evidence has been provided by Manufacturer that they meet the following condition(s) for the certificates issued by DEKRA in accordance with Directive 93/42/EEC to remain valid:

- Manufacturer holds certificates issued by DEKRA in accordance with Directive 93/42/EEC that were still valid on 26 May 2021 and that have not been withdrawn afterwards and were not expired on 20 March 2023. The certificates, if expired, can be considered to be valid, provided that the following conditions are met by the dates indicated:
 - (a) Manufacturer has already lodged a formal application with DEKRA in accordance with MDR 2017/745 Section 4.3, first subparagraph, of Annex VII for conformity assessment in respect of the device or in respect of the device intended to substitute that device.
 - (b) For the conditions to be met for the certificate to remain valid DEKRA to which the formal application has been made and Manufacturer must have signed a written agreement in accordance with MDR 2017/745 Section 4.3, second subparagraph, of Annex VII, by no later than 26 September 2024. Should this agreement not be signed by 26 September 2024 the certificate cannot be considered valid.

Based on evidence provided by Manufacturer it has been determined that the certificates according to MDD 93/42/EEC issued by DEKRA Certification GmbH for the devices indicated in annex 1 meet the requirements to remain valid:

By signing this agreement Manufacturer also confirms that the following additional requirements of MDR 2017/745 Article 120 3c, as amended by Regulation (EU) 2023/607, are met, and will continue to be met, for all products listed above which will continue to be placed on the market:

- those devices continue to comply with Directive 93/42/EEC, as applicable;
- there are no significant changes in the design and intended purpose;
- the devices do not present an unacceptable risk to the health or safety of patients, users or other persons, or to other aspects of the protection of public health;

Following from the above information from Manufacturer DEKRA agrees to be the notified body responsible for the continued appropriate surveillance in accordance with applicable requirements, and in the respect of the applicable devices identified above, as stipulated in MDR 2017/745 Article 120 3e, as amended by Regulation (EU) 2023/607, DEKRA. This appropriate surveillance shall include at least:

- Surveillance audits in accordance with Directive 93/42/EEC (as applicable), considering also MDR 2017/745 requirements for post market surveillance, vigilance, registration of

Extension Agreement

economic operators and of devices as required by MDR 2017/745 Article 120. This can also include unannounced audits.

- Assessment of reportable changes
- Assessment of reportable adverse events (vigilance) for impact on certification status

For the specific devices given above for which the certificate can still be considered valid, the certificate validity date and dates until when the products may be placed on the market or put into service are as follows.

Type of Device	Date until which certificate can still be considered valid
Class III Class IIb implantable devices excluding well-established technologies (sutures, staples, dental fillings, dental braces, tooth crowns, screws, wedges, plates, wires, pins, clips and connectors)	31 December 2027
Class IIb devices Class IIb implantable devices which are well-established technologies (sutures, staples, dental fillings, dental braces, tooth crowns, screws, wedges, plates, wires, pins, clips and connectors) Class IIa devices Class I sterile devices Class I devices with a measuring function	31 December 2028

The table above thus also defines the dates until which DEKRA is responsible for the appropriate surveillance, unless one of the following situations applies:

- Manufacturer provides a Notification of Change to inform DEKRA that devices will no longer be placed on the market or put into service and the certificate should no longer be considered to be valid
- DEKRA is not the notified body with which the written agreement has been signed for conformity assessment of the device or substitute device in accordance with MDR 2017/745. In this case the notified body with which the written agreement has been signed for conformity assessment of the device or substitute device must take responsibility for surveillance of the device which has a certificate that was issued in accordance with Directive 93/42/EEC. This should be no later than 26 September 2024 as detailed in MDR 2017/745 Article 120 3e, as amended by Regulation (EU) 2023/607. Thus DEKRA's responsibility for surveillance will end on 26 September 2024 in this case, or before if a Notification of Change is provided to confirm that the surveillance activities are now carried out by another Notified Body.

Extension Agreement

Finally, by signing this agreement DEKRA and Manufacturer agree that the products covered by the Directive 93/42/EEC certificates listed in annex 1 will thus continue to remain valid until the dates as stipulated above, in order for DEKRA to meet the required surveillance responsibilities.

This Extension Agreement is based on the General Terms and Conditions, the General Certification Conditions and the Specific Certification Conditions (MDR/IVDR) of DEKRA Certification GmbH. The following hierarchy applies: Specific Certification Conditions (1); General Certification Conditions (2); General Terms and Conditions (3). The provisions in this agreement take precedence over the General Terms and Conditions and the General and Specific Certification Conditions.

Should you agree with the above please confirm this through a signature below.

We look forward to our successful cooperation.

DEKRA Certification GmbH



Digitally signed by Markus
RAINER Kopf
Date: 2024-06-18 16:06:22+02:00

Stuttgart, 2024-06-18

Client

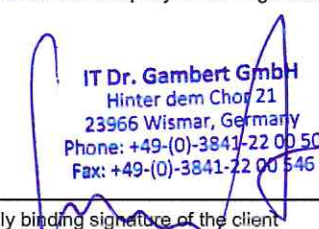
IT Dr. Gambert GmbH	Hinter dem Chor 21 23966 Wismar Germany
Name of the company submitting the application	Address of the company submitting the application
<u>CEO, DEWAN GAMBERT</u> Title, first name, last name of the client	 IT Dr. Gambert GmbH Hinter dem Chor 21 23966 Wismar, Germany Phone: +49-(0)-3841-22 00 50 Fax: +49-(0)-3841-22 00 546
Wismar, <u>2024-06-18</u> Place and Date (YYYY-MM-DD)	legally binding signature of the client

Extension Agreement

Annex 1

The following products are covered by this extension agreement

Device name or Basic UDI-DI (under MDR application)	MDR Device classification (as proposed by the manufacturer and verified at the pre-application stage)	If the MDR device is a substitute device, identification of the corresponding MDD/AIMDD device	MDD/AIMDD Certificate Reference(s) of the devices under MDR application, and the NB Identification
oxygen sensors M-02	Class IIa	N/A	Certificate 50403-16-07
oxygen sensors M-02L2	Class IIa	N/A	Certificate 50403-16-07
oxygen sensors M-02T	Class IIa	N/A	Certificate 50403-16-07
oxygen sensors M-02TL2	Class IIa	N/A	Certificate 50403-16-07
oxygen sensors M-01	Class IIa	N/A	Certificate 50403-16-07
oxygen sensors M-01L2	Class IIa	N/A	Certificate 50403-16-07
oxygen sensors M-01T	Class IIa	N/A	Certificate 50403-16-07
oxygen sensors M-01TL2	Class IIa	N/A	Certificate 50403-16-07
oxygen sensors M-03	Class IIa	N/A	Certificate 50403-16-07
oxygen sensors M-03HDM	Class IIa	N/A	Certificate 50403-16-07
oxygen sensors M-03T	Class IIa	N/A	Certificate 50403-16-07
oxygen sensors M-04	Class IIa	N/A	Certificate 50403-16-07
oxygen sensors M-04T	Class IIa	N/A	Certificate 50403-16-07
oxygen sensors M-04C	Class IIa	N/A	Certificate 50403-16-07
oxygen sensors M-04CT	Class IIa	N/A	Certificate 50403-16-07
oxygen sensors M-07	Class IIa	N/A	Certificate 50403-16-07
oxygen sensors M-07T	Class IIa	N/A	Certificate 50403-16-07
oxygen sensors M-07S	Class IIa	N/A	Certificate 50403-16-07
oxygen sensors M-07ST	Class IIa	N/A	Certificate 50403-16-07
oxygen sensors M-08	Class IIa	N/A	Certificate 50403-16-07
oxygen sensors M-08T	Class IIa	N/A	Certificate 50403-16-07
oxygen sensors M-09	Class IIa	N/A	Certificate 50403-16-07
oxygen sensors M-09T	Class IIa	N/A	Certificate 50403-16-07

Extension Agreement

oxygen sensors M-10	Class IIa	N/A	Certificate 50403-16-07
oxygen sensors M-11	Class IIa	N/A	Certificate 50403-16-07
oxygen sensors M-12	Class IIa	N/A	Certificate 50403-16-07
oxygen sensors M-12A	Class IIa	N/A	Certificate 50403-16-07
oxygen sensors M-12T	Class IIa	N/A	Certificate 50403-16-07
oxygen sensors M-14	Class IIa	N/A	Certificate 50403-16-07
oxygen sensors M-14T	Class IIa	N/A	Certificate 50403-16-07
oxygen sensors M-14ST	Class IIa	N/A	Certificate 50403-16-07
oxygen sensors M-15	Class IIa	N/A	Certificate 50403-16-07
oxygen sensors M-15T	Class IIa	N/A	Certificate 50403-16-07
oxygen sensors M-15M	Class IIa	N/A	Certificate 50403-16-07
oxygen sensors M-16	Class IIa	N/A	Certificate 50403-16-07
oxygen sensors M-16T	Class IIa	N/A	Certificate 50403-16-07
oxygen sensors M-16HT	Class IIa	N/A	Certificate 50403-16-07
oxygen sensors M-16HTT	Class IIa	N/A	Certificate 50403-16-07
oxygen sensors M-18T	Class IIa	N/A	Certificate 50403-16-07
oxygen sensors M-18CT	Class IIa	N/A	Certificate 50403-16-07
oxygen sensors M-25	Class IIa	N/A	Certificate 50403-16-07
oxygen sensors M-25T	Class IIa	N/A	Certificate 50403-16-07
oxygen sensors M-43	Class IIa	N/A	Certificate 50403-16-07
oxygen sensors M-43T	Class IIa	N/A	Certificate 50403-16-07
oxygen sensors M-43GE	Class IIa	N/A	Certificate 50403-16-07
oxygen sensors M-44	Class IIa	N/A	Certificate 50403-16-07
oxygen sensors M-45	Class IIa	N/A	Certificate 50403-16-07
oxygen sensors M-47	Class IIa	N/A	Certificate 50403-16-07
oxygen sensors M-48	Class IIa	N/A	Certificate 50403-16-07
oxygen sensors M-80	Class IIa	N/A	Certificate 50403-16-07
oxygen sensors MLF-03	Class IIa	N/A	Certificate 50403-16-07

Extension Agreement

oxygen sensors MLF-04	Class IIa	N/A	Certificate 50403-16-07
oxygen sensors MLF-11K	Class IIa	N/A	Certificate 50403-16-07
oxygen sensors MLF-12A	Class IIa	N/A	Certificate 50403-16-07
oxygen sensors MLF-15	Class IIa	N/A	Certificate 50403-16-07
oxygen sensors MLF-15M	Class IIa	N/A	Certificate 50403-16-07
oxygen sensors MLF-16	Class IIa	N/A	Certificate 50403-16-07
oxygen sensors MLF-16D	Class IIa	N/A	Certificate 50403-16-07
oxygen sensors MLF-16DD	Class IIa	N/A	Certificate 50403-16-07
oxygen sensors MLF-16DE	Class IIa	N/A	Certificate 50403-16-07
oxygen sensors MLF-16H	Class IIa	N/A	Certificate 50403-16-07
oxygen sensors MLF-16HL	Class IIa	N/A	Certificate 50403-16-07
oxygen sensors MLF-17	Class IIa	N/A	Certificate 50403-16-07
oxygen sensors MLF-19	Class IIa	N/A	Certificate 50403-16-07
oxygen sensors MLF-19GE	Class IIa	N/A	Certificate 50403-16-07
oxygen sensors MLF-42HL	Class IIa	N/A	Certificate 50403-16-07
oxygen sensors MLF-43	Class IIa	N/A	Certificate 50403-16-07
oxygen sensors MLF-44	Class IIa	N/A	Certificate 50403-16-07
oxygen sensors MLF-60 HC	Class IIa	N/A	Certificate 50403-16-07
oxygen sensors MLF-80	Class IIa	N/A	Certificate 50403-16-07
oxygen sensors MLF-80HL	Class IIa	N/A	Certificate 50403-16-07

DEKRA Certification GmbH – Handwerkstraße 15 – D-70565 Stuttgart

IT Dr. Gambert GmbH
Herr Demian GAMBERT
Hinter dem Chor 21
23966 Wismar
Germany

DEKRA Certification GmbH

Handwerkstraße 15
D-70565 Stuttgart

Contact Julia Scheu
Phone +49.711.7861-4158
Fax +49.711.7861-2615
Email julia.scheu@dekra.com

Headquarters
Phone +49.711.7861-2566
Fax +49.711.7861-2615

Date 2024-09-27

Subject: Notified Body Confirmation Letter

Our reference: 50403-CoL-01 Rev. 0

Confirmation of the status of a formal application, written agreement, and appropriate surveillance in the framework of Regulation (EU) 2023/607 amending Regulations (EU) 2017/745 as regards the transitional provisions for certain medical devices and in vitro diagnostic medical devices

Dear Mr. Gambert

This letter confirms that, DEKRA Certification GmbH, a Notified Body (NB) designated against Regulation (EU) 2017/745 (MDR) and identified by the number 0124 on NANDO, has received a formal application in accordance with Section 4.3, first subparagraph of Annex VII of MDR and has signed a written agreement in accordance with Section 4.3, second subparagraph of Annex VII of MDR with the following manufacturer:

IT Dr. Gambert GmbH
Hinter dem Chor 21
23966 Wismar
Deutschland

SRN Number: DE-MF-000004930

The devices covered by the formal application and the written agreement mentioned above are identified in the Tables 1 and 2 below. Table 1 identifies the devices for which an MDR application has been received, written agreement concluded and for which the NB is also responsible for appropriate surveillance of the corresponding devices under the applicable Directive MDD. Table 2 identifies the devices for which an MDR application has been received and a written agreement concluded, but the NB has not yet taken the responsibility for appropriate surveillance of the corresponding devices under the applicable Directive MDD.

In the case of devices covered by certificates issued under Directive 93/42/EEC (MDD) that expired after 26 May 2021 and before 20 March 2023, without having been withdrawn, this letter also confirms that the manufacturer signed the written agreement under MDR by the

date of MDD certificate expiry; or provided evidence that a competent authority of a Member State had granted a derogation or exemption from the applicable conformity assessment procedure in accordance with Article 59(1) of MDR or Article 97(1) of the MDR respectively, by the 20 Mar 2023 for the relevant devices.

The transition timelines that apply to the devices covered by this letter, subject to the manufacturer's continued compliance to the other conditions specified in Article 120.3c of MDR (as amended by (EU) 2023/607), are shown below:

- 26 May 2026 for Class III custom-made implantable devices
- 31 December 2027 for Class III devices and Class IIb implantable devices excluding Well-established technologies (WET - sutures, staples, dental fillings, dental braces, tooth crowns, screws, wedges, plates, wires, pins, clips and connectors)
- 31 December 2028 for other Class IIb devices, Class IIa, Class I devices placed on the market in sterile condition or have a measuring function
- 31 December 2028 for devices not requiring the involvement of a notified body under MDD but requiring it under MDR (e.g., class I devices that qualify as re-usable surgical instruments)

Validity of this confirmation letter:

For products included in table 1

Until the end of applicable transition timelines specified in Article 120.3c of MDR (as amended by (EU) 2023/607)

On behalf of the Notified Body,



Digital unterschrieben von Markus
RAINER Kopf
Datum: 2024-09-27
13:53:33+02:00

Markus Kopf
2024/09/27

Enclosures:

Confirmation Letter Annex

Annex to Notified Body Confirmation Letter 50403-CoL-01 Rev. 0

Table 1:

Device name or Basic UDI-DI (under MDR application)	MDR Device classification (as proposed by the manufacturer and verified at the pre-application stage)	If the MDR device is a substitute device, identification of the corresponding MDD/AIMDD device	MDD/AIMDD Certificate Reference(s) of the devices under MDR application, and the NB Identification
Medical oxygen sensor M-01	Class IIa	N/A	Certificate 50403-16-07
Medical oxygen sensor M-01L2	Class IIa	N/A	Certificate 50403-16-07
Medical oxygen sensor M-01T	Class IIa	N/A	Certificate 50403-16-07
Medical oxygen sensor M-01TL2	Class IIa	N/A	Certificate 50403-16-07
Medical oxygen sensor M-02	Class IIa	N/A	Certificate 50403-16-07
Medical oxygen sensor M-02L2	Class IIa	N/A	Certificate 50403-16-07
Medical oxygen sensor M-02T	Class IIa	N/A	Certificate 50403-16-07
Medical oxygen sensor M-02TL2	Class IIa	N/A	Certificate 50403-16-07
Medical oxygen sensor M-03	Class IIa	N/A	Certificate 50403-16-07
Medical oxygen sensor M-03HDM	Class IIa	N/A	Certificate 50403-16-07
Medical oxygen sensor M-03T	Class IIa	N/A	Certificate 50403-16-07
Medical oxygen sensor M-04	Class IIa	N/A	Certificate 50403-16-07
Medical oxygen sensor M-04T	Class IIa	N/A	Certificate 50403-16-07
Medical oxygen sensor M-04C	Class IIa	N/A	Certificate 50403-16-07
Medical oxygen sensor M-04CT	Class IIa	N/A	Certificate 50403-16-07
Medical oxygen sensor M-07	Class IIa	N/A	Certificate 50403-16-07
Medical oxygen sensor M-07T	Class IIa	N/A	Certificate 50403-16-07
Medical oxygen sensor M-07S	Class IIa	N/A	Certificate 50403-16-07

Device name or Basic UDI-DI (under MDR application)	MDR Device classification (as proposed by the manufacturer and verified at the pre-application stage)	If the MDR device is a substitute device, identification of the corresponding MDD/AIMDD device	MDD/AIMDD Certificate Reference(s) of the devices under MDR application, and the NB Identification
Medical oxygen sensor M-07ST	Class IIa	N/A	Certificate 50403-16-07
Medical oxygen sensor M-08	Class IIa	N/A	Certificate 50403-16-07
Medical oxygen sensor M-08T	Class IIa	N/A	Certificate 50403-16-07
Medical oxygen sensor M-09	Class IIa	N/A	Certificate 50403-16-07
Medical oxygen sensor M-09T	Class IIa	N/A	Certificate 50403-16-07
Medical oxygen sensor M-10	Class IIa	N/A	Certificate 50403-16-07
Medical oxygen sensor M-11	Class IIa	N/A	Certificate 50403-16-07
Medical oxygen sensor M-12	Class IIa	N/A	Certificate 50403-16-07
Medical oxygen sensor M-12A	Class IIa	N/A	Certificate 50403-16-07
Medical oxygen sensor M-12T	Class IIa	N/A	Certificate 50403-16-07
Medical oxygen sensor M-14	Class IIa	N/A	Certificate 50403-16-07
Medical oxygen sensor M-14T	Class IIa	N/A	Certificate 50403-16-07
Medical oxygen sensor M-14ST	Class IIa	N/A	Certificate 50403-16-07
Medical oxygen sensor M-15	Class IIa	N/A	Certificate 50403-16-07
Medical oxygen sensor M-15T	Class IIa	N/A	Certificate 50403-16-07
Medical oxygen sensor M-15M	Class IIa	N/A	Certificate 50403-16-07
Medical oxygen sensor M-16	Class IIa	N/A	Certificate 50403-16-07
Medical oxygen sensor M-16T	Class IIa	N/A	Certificate 50403-16-07
Medical oxygen sensor M-16HT	Class IIa	N/A	Certificate 50403-16-07
Medical oxygen sensor M-16HTT	Class IIa	N/A	Certificate 50403-16-07
Medical oxygen sensor M-18T	Class IIa	N/A	Certificate 50403-16-07
Medical oxygen sensor M-18CT	Class IIa	N/A	Certificate 50403-16-07
Medical oxygen sensor M-25	Class IIa	N/A	Certificate 50403-16-07
Medical oxygen sensor M-25T	Class IIa	N/A	Certificate 50403-16-07
Medical oxygen sensor M-43	Class IIa	N/A	Certificate 50403-16-07
Medical oxygen sensor M-43T	Class IIa	N/A	Certificate 50403-16-07
Medical oxygen sensor M-43GE	Class IIa	N/A	Certificate 50403-16-07
Medical oxygen sensor M-44	Class IIa	N/A	Certificate 50403-16-07

Device name or Basic UDI-DI (under MDR application)	MDR Device classification (as proposed by the manufacturer and verified at the pre-application stage)	If the MDR device is a substitute device, identification of the corresponding MDD/AIMDD device	MDD/AIMDD Certificate Reference(s) of the devices under MDR application, and the NB Identification
Medical oxygen sensor M-45	Class IIa	N/A	Certificate 50403-16-07
Medical oxygen sensor M-47	Class IIa	N/A	Certificate 50403-16-07
Medical oxygen sensor M-48	Class IIa	N/A	Certificate 50403-16-07
Medical oxygen sensor M-80	Class IIa	N/A	Certificate 50403-16-07
Medical oxygen sensor MLF-03	Class IIa	N/A	Certificate 50403-16-07
Medical oxygen sensor MLF-04	Class IIa	N/A	Certificate 50403-16-07
Medical oxygen sensor MLF-11K	Class IIa	N/A	Certificate 50403-16-07
Medical oxygen sensor MLF-12A	Class IIa	N/A	Certificate 50403-16-07
Medical oxygen sensor MLF-15	Class IIa	N/A	Certificate 50403-16-07
Medical oxygen sensor MLF-15M	Class IIa	N/A	Certificate 50403-16-07
Medical oxygen sensor MLF-16	Class IIa	N/A	Certificate 50403-16-07
Medical oxygen sensor MLF-16D	Class IIa	N/A	Certificate 50403-16-07
Medical oxygen sensor MLF-16DD	Class IIa	N/A	Certificate 50403-16-07
Medical oxygen sensor MLF-16DE	Class IIa	N/A	Certificate 50403-16-07
Medical oxygen sensor MLF-16H	Class IIa	N/A	Certificate 50403-16-07
Medical oxygen sensor MLF-16HL	Class IIa	N/A	Certificate 50403-16-07
Medical oxygen sensor MLF-17	Class IIa	N/A	Certificate 50403-16-07
Medical oxygen sensor MLF-19	Class IIa	N/A	Certificate 50403-16-07
Medical oxygen sensor MLF-19GE	Class IIa	N/A	Certificate 50403-16-07
Medical oxygen sensor MLF-42HL	Class IIa	N/A	Certificate 50403-16-07
Medical oxygen sensor MLF-43	Class IIa	N/A	Certificate 50403-16-07
Medical oxygen sensor MLF-44	Class IIa	N/A	Certificate 50403-16-07
Medical oxygen sensor MLF-60 HC	Class IIa	N/A	Certificate 50403-16-07
Medical oxygen sensor MLF-80	Class IIa	N/A	Certificate 50403-16-07
Medical oxygen sensor MLF-80HL	Class IIa	N/A	Certificate 50403-16-07