



/ **77 ELEKTRONIKA KFT.**
H-1116 Budapest, Fehérvári út 98.
/ Telefon +36 1 206 1480
/ Web: **E77.HU**

For submission at the competent

Authorities of Republic of Moldova

Letter of Authorization

Whereas, **77 Elektronika Kft** (based at Fehérvári út 98, 1116 – Budapest (Hungary) as manufacturer of Urilyzer® Cell (Urine Microscopy Analyzer) and Urilyzer® Cell Cuvettes (Cuvette for Urine Microscopy Analyzer) do hereby declare that

Sanmedico SRL, str. Petricani 88/1, 0259 Chisinau - Republic of Moldova

is authorized to register, import, promote sell and support the above-mentioned products under the trademark "Urilyzer®" non-exclusively within the territory of Republic of Moldova as a Distributor. We authorize **Sanmedico SRL** to overtake the procedures regarding the registration of the mentioned products at the Authorities of Republic of Moldova. **Sanmedico SRL** is authorized to participate in tenders only in the territory of Republic of Moldova.

Analyticon Biotechnologies GmbH (based at Am Muehlenberg 10, 35104 Lichtenfels (Germany) as distributor of 77 Elektronika Kft is the owner of the trademark "Urilyzer®". 77 Elektronika Kft confirms, that Analyticon Biotechnologies GmbH is the brand owner of the above-mentioned products.

This Letter of Authorization is valid until 31.12.2023. It could be elongated by 77 Elektronika Kft for another period in accordance with **Sanmedico SRL** Cancellation must be in writing with a cancellation period of 3 Months for each party.

For and on behalf of 77 Elektronika Kft

Signed on 17th July 2023, Budapest, Hungary

Sándor Zettwitz

managing director

77 Elektronika Műszeripari Kft.
H-1116 Budapest,
Fehérvári út 98.
23.

/ CÉGJEGYZÉK SZÁMA: 01 09 061328 / ALAPÍTVÁ: 1986 / BBRT 10102093 – 01196703 - 00000005



Management
Systems
ISO 9001
ISO 13485
ISO 14001
www.tuv.com

STATEMENT

We, **Norma Instruments Zrt.** having a registered office at Papírgyár u. 58-59., 1038 Budapest, Hungary assign **SRL SANMEDICO** having a registered office at A. Corobceanu street 7A, apt. 9, Chişinău MD-2012, Moldova, as authorized representative in correspondence with the conditions of directive 98/79/EEC.

We declare that the company mentioned above is authorized to register, notify, renew or modify the registration of the following medical devices on the territory of the Republic of Moldova.

Article No. Analyticon	Name
HE3100	Hemolyzer® NG 3
HE5100	Hemolyzer® NG 5
HE5200	Hemolyzer® NG 5 Open
HE3413	H3/5-Hypoclean
HE3701	H3-Compact 100
HE3705	H3-Compact 500
HE5701	H5-Compact 100
HE5704	H5-Compact 400
HE5707	H5-Compact 100-O
HE5709	H5-Compact 250-O
HE3422	H5-Opticlean
HE3504	H3-Check Complete
HE3505	H3-Check Normal
HE5504	H5-Check Complete
HE5505	H5-Check Normal
HE3611	H3/5-Cal

This authorization letter is valid until the following date or withdrawal: **2025.12.31.**

Date: 2023.09.18.

Signature:

Gergely Domonkos Horváth
 Chief Executive Officer
 Norma Instruments Zrt.

NORMA INSTRUMENTS Zrt.
 1038 Budapest
 Papírgyár u. 58-59.
 Adószám: 24742159-2-41

Mj

Certificate



Quality Management System EN ISO 13485:2016

Registration No.: SX 1006099-1

Organization: 77 Elektronika Műszeripari Kft.
Fehérvári út 98.
1116 Budapest
Hungary

Scope: Design and development, production, distribution, installation and servicing of blood glucose measuring systems, urine analyzers and rapid test readers, including related consumables.

The Certification Body of TÜV Rheinland LGA Products GmbH certifies that the organization has established and applies a quality management system for medical devices. Proof has been furnished that the requirements specified in the abovementioned standard are fulfilled. The quality management system is subject to yearly surveillance.

Report No.: 93389457-30
Effective date: 2022-11-18
Expiry date: 2025-11-17
Issue date: 2022-11-09

A blue ink signature is written over a circular seal. The seal contains the TÜV Rheinland logo and the text 'TÜV Rheinland LGA Products GmbH' and 'Zertifizierungsstelle'.

Rafał Byczkowski
TÜV Rheinland LGA Products GmbH
Tillystraße 2 · 90431 Nürnberg · Germany



Certificate



Quality Management System EN ISO 13485:2016

Registration No.: SX 1006099-1

Organization: 77 Elektronika Műszeripari Kft.
Fehérvári út 98.
1116 Budapest
Hungary

The scope of certification includes the following additional sites:

No.	Facility	Scope
/01	Elektronika Műszeripari Kft. Fehérvári út 98. 1116 Budapest Hungary	Design and development, production, distribution, installation and servicing.
/02	77 Elektronika Műszeripari Kft. Telephely Sztregova utca 1 1116 Budapest Hungary	Manufacture and warehouse of blood glucose measuring systems, urine analyzers, related consumables and parts. Manufacturing of SMT technology.

Report No.: 93389457-30
Effective date: 2022-11-18
Expiry date: 2025-11-17
Issue date: 2022-11-09

A blue ink signature is written over a circular blue stamp. The stamp contains the TÜVRheinland logo and the text 'TÜVRheinland LGA Products GmbH' and 'Zertifizierungsstelle'.

Rafał Byczkowski
TÜV Rheinland LGA Products GmbH
Tillystraße 2 · 90431 Nürnberg · Germany



This is a translation of the certificate HU15/7647

The management system of

NORMA Instruments Zrt.

H-1038 Budapest Papírgyár u. 58-59.

has been assessed and certified as meeting the requirements of

MSZ EN ISO 13485:2016

For the following activities

Development, production and distribution of haematology blood analysis systems and haematology reagents for the in-vitro diagnostic (IVD) market.

This certificate is valid from 12 May 2023 until 28 April 2024 and remains valid subject to satisfactory surveillance audits.

Issue 4. Certified since 29 April 2015

Certified activities performed by additional sites are listed on subsequent pages.



Authorised by
Andras Tohl

SGS Hungária Kft.
1124 Budapest, Sirály u. 4.
t +3613093340 - www.sgs.hu



This document is an authentic electronic certificate for Client' business purposes use only. Printed version of the electronic certificate are permitted and will be considered as a copy. This document is issued by the Company subject to SGS General Conditions of certification services available on [Terms and Conditions](#) | SGS. Attention is drawn to the limitation of liability, indemnification and jurisdictional clauses contained therein. This document is copyright protected and any unauthorized alteration, forgery or falsification of the content or appearance of this document is unlawful.



This is a translation of the certificate HU15/7647, continued

NORMA Instruments Zrt.

MSZ EN ISO 13485:2016

Issue 4
Sites
NORMA Instruments Zrt. H-1038 Budapest Papírgyár u. 58-59.
Development, production and distribution of haematology blood analysis systems for the in-vitro diagnostic (IVD) market.
NORMA Instruments Zrt. H-1044 Budapest, Ezred u. 2.
Warehousing, packaging and distribution activity in support of Development, production and distribution of haematology blood analysis systems and haematology reagents for the in-vitro diagnostic (IVD) market.



This document is an authentic electronic certificate for Client' business purposes use only. Printed version of the electronic certificate are permitted and will be considered as a copy. This document is issued by the Company subject to SGS General Conditions of certification services available on [Terms and Conditions](#) | SGS. Attention is drawn to the limitation of liability, indemnification and jurisdictional clauses contained therein. This document is copyright protected and any unauthorized alteration, forgery or falsification of the content or appearance of this document is unlawful.



CERTIFICATE



EN ISO 13485:2016

DEKRA Certification GmbH hereby certifies that the organization

Analyticon Biotechnologies GmbH

Scope of certification:

Development, production and distribution of in-vitro diagnostics from the field of urine diagnostics for professional and near-patient applications

Distribution, service and installation of in-vitro-diagnostic analyzers from the field of urine diagnostics.

Distribution of in-vitro diagnostic devices from the field of hematology

Distribution and service of in-vitro-diagnostic analyzers from the field of hematology

Certified location:

Am Mühlenberg 10, 35104 Lichtenfels, Germany
(further locations see annex)

has established and maintains a quality management system according to the above mentioned standard. The conformity was adduced with audit report no. 51519-R1-00.

Certificate registration no.: 51519-14-02_EN

Certificate valid from: 2023-03-06

Validity of previous certificate: 2023-03-05

Certificate valid to: 2025-01-10

Karin Leicht

DEKRA Certification GmbH, Stuttgart, 2023-03-06



Annex to the Certificate No. 51519-14-02

valid from 2023-03-06 to 2025-01-10

The following locations/companies belong to the certificate above:

	Headquarters	Scope of certification
	Analyticon Biotechnologies GmbH Am Mühlberg 10 35104 Lichtenfels Germany	see page 1
	at the following locations/at the companies at the following locations	Scopes of certification
1.	Am Teichsberg 10 Lichtenfels-Sachsenberg Germany	Reception, shipping and storage of raw materials, semi-finished goods, finished goods and analyzers from the fields of urine diagnostics and hematology.



Karin Leicht

Karin Leicht
DEKRA Certification GmbH, Stuttgart, 2023-03-06

EC Declaration of Conformity

Manufacturer's name:	Norma Instruments Zrt.
Headquarters:	Papírgyár u. 58-59., 1038 Budapest, Hungary
Products:	Hemolyzer[®] 3 NG
REF.- Number:	HE3100
Directives:	98/79/EC on <i>in vitro</i> diagnostic medical devices (IVD) Classification: General/Other IVD – Outside Annex II and not for self-testing 2011/65/EU on restriction of hazardous substances (ROHS) Classification: Category 8 Medical Device 2015/863/EU amending Annex II to Directive 2011/65/EU of the European Parliament and of the Council as regards the list of restricted substances 2014/30/EC on electromagnetic compatibility (EMC) 2014/35/EC on low voltage (LVD)
Standards:	MSZ EN 13612:2007, MSZ EN ISO 14971:2020, MSZ EN ISO 15223-1:2022, MSZ EN ISO 18113-1:2012, MSZ EN ISO 18113-3:2012, MSZ EN 50581:2013, EN 55011:2016, EN 61000-3-2:2019, EN 61000-3-3: 2013 + A1:2019, MSZ EN 61010-1:2011, MSZ EN 61010-2-101:2017, EN 61326-1: 2013, MSZ EN 61326-2-6:2013, EN 62304:2006, MSZ EN 62366-1:2015

We, **Norma Instruments Zrt.**, do herewith declare under our sole responsibility that the **CE marked** In Vitro Diagnostic Medical Device

Hemolyzer[®] 3 NG

is in conformity with the Essential Requirements of **Annex I** and with the requirements listed in **Annex III** by the **Directive 98/79/EC** on *in vitro* diagnostic medical devices (*IVD Directive*),

and is in conformity with the requirements of the harmonized quality management system of **EN ISO 13485:2016**.

Budapest, 2022/05/16

NORMA INSTRUMENTS Zrt.
 1038 Budapest
 Papírgyár u. 58-59.
 Adószám: 24742159-2-41

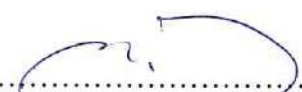

.....

 Gergely Domonkos Horváth
 Chief Executive Officer
 Norma Instruments Zrt.

74

EC Declaration of Conformity

Manufacturer's name:	Norma Instruments Zrt.	
Headquarters:	Papírgyár u. 58-59., 1038 Budapest, Hungary	
Products:	Hemolyzer® Control Materials	
	Product Names	Product Codes
	H3-Check Complete	HE3504
	H3-Check Normal	HE3505
	H5-Check Complete	HE5504
	H5-Check Normal	HE5505
	H3/5-CAL	HE3611
Directives:	98/79/EC on <i>in vitro</i> diagnostic medical devices (IVD) Classification: General/Other IVD – Outside Annex II and not for self-testing 2011/65/EU on restriction of hazardous substances (ROHS) Classification: Category 8 Medical Device 2015/863/EU amending Annex II to Directive 2011/65/EU of the European Parliament and of the Council as regards the list of restricted substances 1907/2006/EC on Registration, Evaluation, Authorisation and Restriction of Chemicals (REACH)	
Standards:	EN 13612:2007, EN 13641:2003, EN 14971:2012, EN 15223-1:2017, EN 18113-1:2012, EN 18113-2:2012, EN 23640:2015	

We, **Norma Instruments Zrt.**, do herewith declare under our sole responsibility that the above-mentioned **CE marked** In Vitro Diagnostic Medical Devices

are in conformity with the Essential Requirements of **Annex I** and with the requirements listed in **Annex III** by the **Directive 98/79/EC** on *in vitro* diagnostic medical devices (*IVD Directive*),

and are in conformity with the requirements of the harmonized quality management system of **EN ISO 13485:2016**.

Budapest, 2022/05/16



.....
 Gergely Domonkos Horváth
 Chief Executive Officer
 Norma Instruments Zrt.

EU DECLARATION OF CONFORMITY

Manufacturer's Information

Manufacturer's Name:	Norma Instruments Zrt.
Manufacturer's SRN:	HU-MF-000014244
Manufacturer's Address:	Papírgyár u. 58-59., 1038 Budapest, Hungary

Product Information

Product Name:	H3/5-Hypoclean
Product Code:	HE3413
Basic UDI-DI:	59991062iHCleanV4
Intended Purpose:	H3/5-Hypoclean detergent is a stabilized and micro-filtered hypochlorite solution for intensive oxidative rinsing and cleaning of capillaries, tubing, and chambers of Hemolyzer® semi-automated hematology analyzers. The detergent is intended for laboratory professional use as an in vitro diagnostic medical device.
Risk Classification:	Class A

Applicable Regulations, Directives and Standards

Regulations:	2017/746/EU on <i>in vitro</i> diagnostic medical devices (IVDR) 1907/2006/EC Registration, Evaluation, Authorization and Restriction of Chemicals (REACH)
Directives:	1272/2008/EC Classification, labelling and packaging of substances and mixtures, amending and repealing Directives 67/548/EEC and 1999/45/EC, and amending Regulation (EC) No 1907/2006

We, **Norma Instruments Zrt.**, as a manufacturer of the above-mentioned CE marked in-vitro medical devices, do hereby declare that this EU Declaration of Conformity is issued under our sole responsibility.

Devices covered by the present EU Declaration of Conformity is in conformity with **Regulation (EU) 2017/746 on in vitro diagnostic medical devices (IVDR)** and other regulations, directives and standards specified above. This declaration is supported by the harmonized quality management system approval of **EN ISO 13485:2016** issued by **SGS Hungary Kft.** (HU15/7647). All supporting documentation is retained at the premise of the manufacturer.

Budapest, 2022/05/16



NORMA INSTRUMENTS Zrt.
1038 Budapest
Papírgyár u. 58-59.
Adószám: 24742159-2-41

.....

 Gergely Domonkos Horváth
 Chief Executive Officer
 Norma Instruments Zrt.

Authorization Certificate



Vitalie Goreacii

SANMEDICO SRL

This is to certify that the above named general manager has successfully completed the full application and technical training which was specifically prepared and carried out on the Analyticon Biotechnologies GmbH equipment mentioned below on May 24th to 25th, 2023

Hemolyzer[®] 3 NG Hemolyzer[®] 5 NG

We hereby state that the general manager is authorized and qualified by Analyticon to do installation, operation, user and technical training, service and maintenance of the equipment listed above.

Analyticon
Biotechnologies GmbH
Customer Support & Trainings



Nathalie Mütze
Manager Customer Support

Leon Preljvukaj
Customer Support

CS_FE_OR_9999

Hemolyzer[®] 3 NG / 5 NG



Innovate your
hematology lab



agile - affordable - accurate

Easy-to-use user interface designed for smart microfluidic analysis

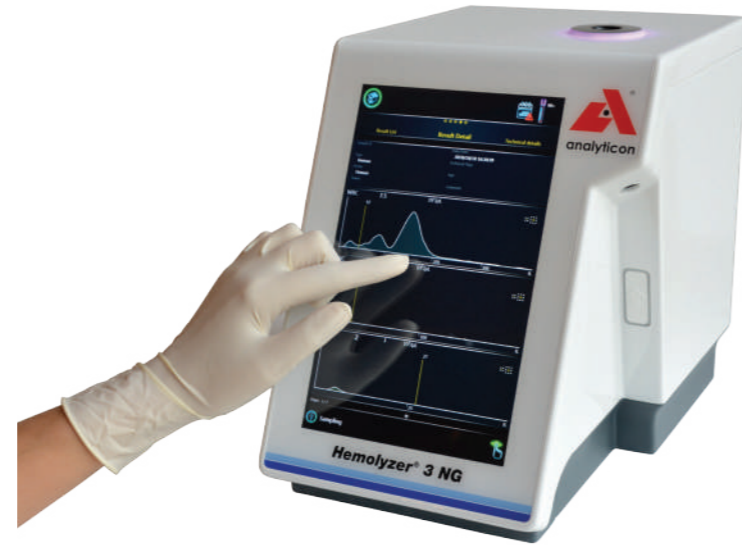

- Gesture-driven user interface via touchscreen
- Time saving and efficient operation
- Microfluidic reagent handling provides minimal reagent volume usage resulting in an optimized and compact reagent concept (reagent packs & cubitainer)

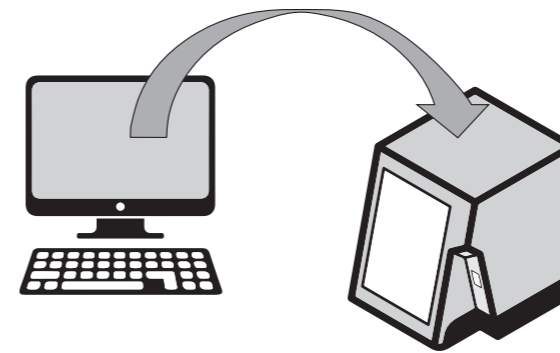

Modern connectivity tools and data management allow state-of-the-art result reporting and instrument analysis

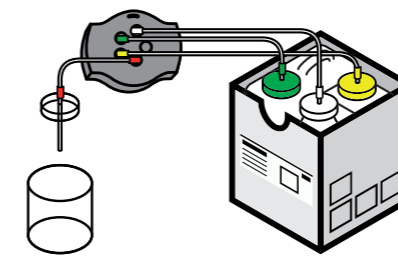

- Option to send results by E-Mail
- Result transfer to LIS via HL7 communication protocol
- Remote access provides online support for efficient troubleshooting and reducing downtime



Low sample volume and small footprint offer numerous applications from emergency room to central lab

- Minimal sample volume due to microfluidic technology allows pediatric sample use and capillary blood handling
- Requires minimum of laboratory work space due to its compact design and small footprint (paper sheet)

The Hemolyzer® NG combines proven reliability and speed with ecological and economical performance

- Correct QC data and reagent information entry by on-board camera
- Significant transport and storage cost savings due to small footprint and compact reagent design
- Minimal user maintenance saves time and guarantees efficient routine operation



Specifications

	Hemolyzer® 3 NG (Art.-No.: HE3100)	Hemolyzer® 5 NG (closed) (Art.-No.: HE5100)	Hemolyzer® 5 NG (open) (Art.-No.: HE5200)
Type	3-part WBC Diff hematology analyzer	5-part WBC Diff hematology analyzer	
Measurement technology	Volumetric impedance method, photometrical method for HGB, microfluidics	Laser based flow cytometry with forward-scattered light detection and volumetric impedance method, photometrical method for HGB, microfluidics	
Parameters	22 parameters: WBC, LYM, MID, GRA, LYM%, MID%, GRA%, HGB, RBC, HCT, MCV, RDWcv, RDWsd, MCH, MCHC, PLT, MPV, PCT, PDWcv, PDWsd, P-LCR%, P-LCC	27 parameters: WBC, LYM, MON, NEU, EOS, BAS, LYM%, MON%, NEU%, EOS% BAS%, RBC, HGB, HCT, MCV, RDWsd/cv, MCH, MCHC, PLT, MPV, PCT, PDWcv, PDWsd, P-LCR%, P-LCC, NLR	
Histogram	WBC, RBC, PLT	RBC, PLT	
Scattergram	–	WBC 5-part-differential	
Sample volume (whole blood)	Aspirated: 13 µl (open vial mode), 38 µl (closed vial mode) Processed: 2.5 µl (both modes)	Aspirated: 38 µl Processed: 2x1.4 µl	
Sampling mode	Closed or open vials	Closed vial mode	Open vial mode
QC management	Levey-Jennings chart / Radar chart		
Throughput	Closed vial mode: 60 tests/hour	60 tests/hour	57 tests/hour
Data storage	40,000 test results including histograms	40,000 test results including histograms and scattergrams	
Display	10.1" LCD touchscreen / Resolution: 800x1280 (portrait)		
Interfaces	LIS (HL7)	LIS (HL7)	LIS (HL7, ASTM)
Connectivity	2 x USB ports, Ethernet, WiFi		
Dimensions	216 x 320 x 280 mm (WxDxH)	216 x 336 x 280 mm (WxDxH)	
Weight	8.7 kg	9.4 kg	8.5 kg
Languages	Bosnian, Bulgarian, Chinese (simplified), English, French, German, Greek, Hungarian, Italian, Polish, Portuguese, Romanian, Russian, Slovenian, Spanish, Turkish, Ukrainian, Vietnamese	Bosnian, English, French, Hungarian, Italian, Portuguese, Romanian, Russian, Spanish, Ukrainian, Vietnamese	
Autosampler	(for Hemolyzer® 5 NG closed), Art.-No.: HE0350; 50 positions		

Reagent	Hemolyzer®	Art.-No.:	Volume or tests
H3-Compact	3 NG	HE3701	100 tests
	3 NG	HE3705	500 tests
H5-Compact	5 NG (closed)	HE5701	100 tests
	5 NG (closed)	HE5704	400 tests
H5-Compact O	5 NG (open)	HE5707	100 tests
	5 NG (open)	HE5709	250 tests



Analyticon Biotechnologies GmbH
Am Muehlenberg 10
35104 Lichtenfels - Germany
Phone: +49 64 54 7991-0
info@analyticon-diagnostics.com
www.analyticon-diagnostics.com



Norma Instruments Zrt.
Papírgyár u.58-59.
1038 Budapest, Hungary



User Manual



**Analyticon
Biotechnologies GmbH**

Am Muehlenberg 10
35104 Lichtenfels - Germany

info@analyticon-diagnostics.com
www.analyticon-diagnostics.com

Contents

Foreword	10
Introduction.....	11
Who should read this manual?.....	11
Symbols used in the manual.....	11
Intended Use	11
Disclaimer	12
Symbols on the outside of the analyzer	13
Technical contact.....	14
Warranty.....	14
Exclusions to warranty.....	15
Measurement technology	16
Impedance based cell counting.....	16
Hemoglobin measurement method	16
Interpreting histograms.....	17
Hematology parameters.....	18
3-part differentiation of White Blood Cells	19
The measurement process	19
Supported blood collection tubes	21
Package contents.....	22
Accessories	23
Identifying parts of the analyzer.....	24
Installing the analyzer.....	26
User serviceable parts	27
Connecting peripheral devices	27
Keyboard (optional)	27
Mouse (optional)	27
Bar code scanner (optional).....	27

- USB flash drive (optional) 27
- USB Wi-Fi Dongle (optional) 28
- Network (“Ethernet”) 28
- Reagent pack..... 28
- Reagent bottles..... 29
- Analyzer packaging material..... 29
- Power..... 30
 - External power supply 30
 - Power button..... 30
 - Power on..... 31
 - Power off 31
 - Emergency power off 32
- Handling reagents..... 32
 - Precautions about reagents 32
 - Reagent characteristics 32
- Blood samples..... 33
 - Taking the sample..... 33
 - Transporting and storing samples 34
 - Sample age..... 34
 - Preparation for analysis..... 34
 - Proper Sample Mixing prior to run..... 35
 - Bubbles in sample..... 36
 - Sample handling 36
- Menu system 37
 - The screen area 37
 - Menu tree..... 38
 - Gestures..... 38
 - Tap 39

Swipe.....	39
Hold.....	40
On-screen keyboard	40
Data input	41
Alphanumeric input	41
External keyboard	41
Barcode input.....	42
Numeric input	42
Description of icons displayed	43
Setup.....	46
Initial setup	46
Language.....	46
Time and date	47
Laboratory specific information (printout contents).....	47
Report output (email)	47
Settings – Customize	48
Appearance	48
Languages	49
Units.....	49
System Settings.....	50
Date and time	50
Email settings.....	50
Network preferences	51
Printout Settings	52
Printout Format	53
Network Printing.....	55
Customization	56
Profiles	57

LIS (Laboratory Information System)	58
Measurement Settings.....	59
Setting up reagents.....	60
Reagent: Pack.....	60
Reagent: Individual Reagents	62
Manual QR code entry	64
Network Settings	65
Wi-Fi settings	66
Wired network settings	66
Daily operation	67
Power on.....	67
Running samples.....	68
Closed tube mode	68
Open tube mode.....	70
Results	72
Short (Quick) result.....	72
Full result (Full screen).....	73
Flags	74
Interpretative Flags.....	78
Reports	79
PDF	79
Printer Thermal.....	80
Printer PCL5/6.....	81
Power off	82
ER mode.....	84
ER Sampling	84
ER Results.....	85
Switching between ER and Admin mode.....	86

Calibration	87
Target values	87
Mode-to-mode calibration	88
Automatic calibration	89
Manual calibration.....	91
QC – Quality Control.....	92
Expected values	92
Assay sheets.....	93
QC diagrams.....	95
QC reports.....	96
Database functions.....	97
Browsing records.....	97
Database context menu.....	98
Selecting records	99
Moving to specific date in database.....	99
Selecting records between two dates	100
Search (filtered view).....	100
Managing data	101
Managing data in Recycle Bin.....	101
Sending e-mail	101
LIS transmission error	102
Maintenance.....	103
Cleaning the analyzer	103
Daily maintenance	103
Weekly maintenance	103
Emergency procedures.....	103
Reagent pack replacement.....	104
Replacing reagent bottles.....	104

Cleaning procedures of the fluidic system	105
Software update	105
Management menu	106
Maintenance	106
Alarm Clock symbol.....	109
Diagnostics.....	110
Service.....	111
Supervision	112
History	112
History details	112
About menu	113
Database capacity.....	114
Status bar.....	115
Technical Specifications.....	116
Performance Data.....	118
Precision	118
Accuracy.....	118
Linearity	118
Display range of parameters	119
Carry-over	120
List of measured parameters.....	120
Known Limitations, interfering substances	121
Low PLT performance	121
PLT clumps	121
HGB interference.....	121
Anti-coagulant used.....	122
Sample age.....	122
Nucleated RBC (nRBC)	122

Electrical block diagram	123
Fluidic diagram	124
Reagent consumption.....	125
Error messages	126
Mechanical Errors.....	126
Operation related errors	127
Electronic errors	129
System (software) errors	129
Troubleshooting	133
Measurement problems	133
Electrical problems	134
Mechanical problems	135
Hydraulic problems.....	136
Network problems.....	137
Printer problems.....	137
Directives and Standards	138

Foreword

Thank you for choosing the Analyticon Hemolyzer 3 NG automated hematology analyzer.

We believe that Hemolyzer 3 NG is the suitable blood cell counter to your needs and will ease your daily laboratory routine.

Welcome to the Analyticon family...

This user manual refers to the following product:

Article number	Product name
REF: HE3100	Hemolyzer® 3 NG



Norma Instruments Zrt.
Address: Papírgyár u. 58-59,
H1038, Budapest, Hungary
www.normadiagnostika.com



Analyticon Biotechnologies GmbH
Address: Am Muehlenberg 10
35104 Lichtenfels, Germany
Tel. +49 6454 79910
Fax. +49 6454 799130
www.analyticon-diagnostics.com
support@analyticon-diagnostics.com

Manual Issue date: **2021/05/05**

Manual Revision: v35

Introduction

Hemolyzer 3 NG is a small, 60 tests/hour impedance-based hematology analyzer for small to medium size laboratory use, performing 3-population analysis of human whole blood samples. Hemolyzer 3 NG is easy to use and uses low amounts of reagent to determine 22 hematology parameters.



Hemolyzer 3 NG's small footprint allows operating in space-constrained environments.

Who should read this manual?

This manual is written for operators of the analyzer describing the structure of the analyzer, daily routine and basic maintenance required to keep the analyzer in good working condition to ensure reliable and dependable operation.

Symbols used in the manual

This User Manual uses symbols listed below to indicate hazards in connection with operating the analyzer. These symbols are used wherever such hazards arise during operation or handling of the analyzer.

Symbol	Meaning
	WARNING Risk of personal injury
	BIOHAZARD Risk of biological infection, contamination

Intended Use

Hemolyzer 3 NG is a 60 tests/hour impedance based IVD hematology analyzer for laboratory use, using specific reagents, performing 3-population, 22 parameters analysis of anti-coagulated human whole blood samples introduced in open or closed vials.

Hemolyzer 3 NG is suitable for use as a Point-of-Care analyzer provided that the analysis results are approved and validated by a trained healthcare professional.

Disclaimer

The manufacturer reserves the right to:

- modify the contents of this manual without prior notice,
- change technology applied within the analyzer without prior notice,
- change technical specifications without prior notice.











The manufacturer does not warrant this manual to be 100% free of unintentional errors.

Please note that this Manual may be revised without prior notification. The Manufacturer reserves the right to change the specifications of the product and/or the contents of this manual as deemed necessary, without prior notice.

Pictures included in this manual may differ from the actual delivered product.

Performance and reliability are never influenced by minor visual differences between this manual and the actual product.

Symbols on the outside of the analyzer

Symbol	Meaning
	WARNING Risk of personal injury
	BIOHAZARD Risk of biological infection, contamination
	CE mark
	for In Vitro Diagnostic use
	Address of manufacturer
	Date of manufacture
	Serial number
	Catalog number
	See instruction for use (manual)
	Waste of electrical and electronic equipment

Technical contact

Hemolyzer 3 NG is a precision laboratory instrument. Its built-in safety measures guarantee safe and reliable operation. Any malfunction is indicated by the software, and suggestions are made to remedy the situation. Being a complex device, there is limited access to internal structures provided to the end user.

Under no circumstances should the Operator attempt to open or remove the outer cover of the analyzer, as this may influence reliable operation and might fool built-in safety measures and can invalidate warranty.

There are no user serviceable parts inside this analyzer. Adjustments of internal structures and repairs of these structures should only be performed by qualified service personnel.

Your local dealer is always ready to help you in case of malfunction.

Analyticon will be doing its best to resolve your problems either directly or indirectly with the help of its local representative.

Warranty

Your Hemolyzer 3 NG comes with a manufacturer's warranty against workmanship defects. Warranty claims must be made through your local representative.

Your supplier will only be able to repair and warrant operation of the analyzer as per its specifications if all service actions are performed by qualified Service Personnel, and the Warranty Label is intact.

Warranty is void if any of the below can be identified, or inoperability, malfunction can be traced back to any of the events listed below:

- broken warranty seal;
- intentional damage and/or modification to the analyzer;
- improper use, use against instructions in this manual, against intended use;
- damage from intentional activities overriding built-in safety logic;
- natural disaster;
- uncertified power supply, or unapproved peripheral has been connected to the analyzer;
- disassembly, repair attempt performed by unauthorized staff;
- damage rooted back to unreported shipping and/or installation induced activities.

The manufacturer does not recommend and support modifying the operating software of this hematology analyzer. The analyzer is able to log and track modifications to the operating software.

- In the case, when the End User required or performed installation of any software product not controlled by the manufacturer and would afterwards experience erroneous or unreliable operation of the analyzer, or would experience erroneous results, then the manufacturer cannot accept any complaints about operation, reliability or performance.

Exclusions to warranty

The below listed items are not covered by warranty unless they were found damaged upon arrival to the End User. In such cases, proper complaint must be filed along with a complaint registered with the forwarder/Distributor company:

- Batteries, external power cable
- Plastic cover elements (including transparent display cover),
- External reagent tubes, rear reagent connector, external reagent connector
- Labels, printed material
- Internal piercing needle, flexible sampling tip, power button, open wash head.

Measurement technology

Hemolyzer 3 NG uses volumetric impedance and photometric method for measurement to provide 22 hematology parameters from 13 μl (open sampling mode) and 38 μl (closed sampling mode) of whole human blood samples.

The measurement cycle time is:

- 60 seconds in closed mode yielding 60 tests/hour throughput, and
- 90 seconds in open sampling mode (40 tests/hour).

Impedance based cell counting

Cells found in a blood sample have various sizes. The volume of these cells can be measured electronically.

A known direct electric current (I) is driven through a small opening (aperture – yellow on figure) with 70 μm (for RBC/PLT detection) and 100 μm (for WBC counting) of diameter separating two liquid compartments containing diluent, that conducts electricity.

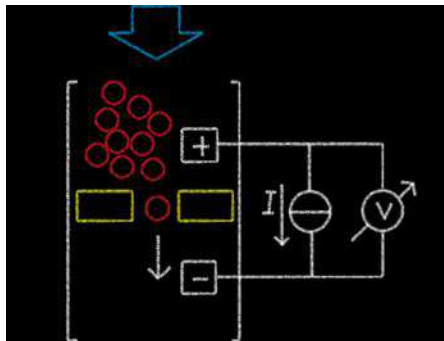

A syringe pump pushes through (blue arrow) the diluted blood sample from one side of the aperture to the other side.

When there is only diluent in the aperture, a certain electric resistance can be measured due to the conductive characteristic of the diluent.

Blood cells do not conduct direct current. When a cell (red circle above) passes through the aperture (yellow) then the resistance of the liquid will increase for the moment the cell passes the aperture. The change of resistance is proportional to the volume of the cell in the aperture. The bigger the change, the bigger the cell passing through the aperture.

Hemoglobin measurement method

Determination of HGB is based on absorption of light of the hemolyzed WBC/HGB blood sample at 540 nm wavelength. A light source (green LED) and detector are located at the bottom of the WBC syringe pump. HGB blank is measured in each measurement cycle to maintain stable HGB results.

Interpreting histograms

Hemolyzer 3 NG presents histograms on its screen, in printed or in electronic format.

WBC histogram shows the identified populations separated by vertical lines (markers), giving an indication of the borders of the populations.

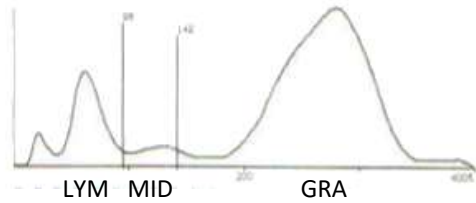

- LYM contains lymphocytes (left of the left side marker)
- MID contains monocytes (between the two markers)
- GRA contains neutrophil, basophil and eosinophil cells (right to the right-side marker)

Note: the above classification is valid for samples run within 12 hours from sampling

The algorithm is looking for populations in the histogram and marks the end of MID population with vertical lines. The lines themselves do not mean that all cells between the markers is the marked (MID) population, rather than the normal distribution curve of the MID population resides between the volumes (fl) indicated by these vertical lines.

RBC and PLT histograms are related in such a way that the front of the RBC histogram is magnified and repeated as the PLT histogram.

The vertical line separating PLT and RBC regions are present on both histograms.

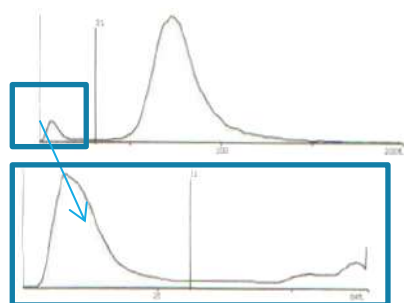

Hematology parameters

Parameter	Explanation	units
WBC	White blood cell count	$10^3/\mu\text{L}$ & $10^9/\text{L}$
LYM#	Lymphocyte count	$10^3/\mu\text{L}$ & $10^9/\text{L}$
MID#	Mid cell count	$10^3/\mu\text{L}$ & $10^9/\text{L}$
GRA#	Granulocyte count	$10^3/\mu\text{L}$ & $10^9/\text{L}$
LYM%	Lymphocyte percentage (of WBC)	%
MID%	Mid cell percentage (of WBC)	%
GRA%	Granulocyte percentage (of WBC)	%
RBC	Red blood cell count	$10^6/\mu\text{L}$ & $10^{12}/\text{L}$
HGB	Hemoglobin	g/dL, g/L, mmol/L
HCT	Hematocrit	%, L/L
MCV	Mean Corpuscular Volume	fL
MCH	Mean Corpuscular HGB	pg, fmol
MCHC	Mean Corpuscular HGB Concentration	g/dL, g/L, mmol/L
RDWsd/cv	Red blood cell distribution width	fL/%
PLT	Platelet (thrombocyte) count	$10^3/\mu\text{L}$ & $10^9/\text{L}$
MPV	Mean Platelet Volume	fL
PCT	Plateletcrit/thrombocrit	%, L/L
PDWsd/cv	Platelet distribution width	fL/%
PLC-R%	Platelet Large Cell Ratio; The ratio of PLT's with volume above 12fl versus total PLT count	%
PLC-C	Platelet Large Cell Count of PLT's with volume above 12fl	$10^3/\mu\text{L}$ & $10^9/\text{L}$

3-part differentiation of White Blood Cells

Three-part white blood cell differential counts (so-called diffs), performed during electrical impedance counting of blood cells, can accurately classify lymphocytes, granulocytes, and mononuclear cells in 85% of specimens, with an error rate not exceeding that of conventional diffs. The differential count is made on diluted specimens and additional hemolyzing agent that breaks down RBC and WBC cell membranes.

Normal RBC's have no nucleus; only WBC nuclei remain in the solution. The size (volume) of various WBC nuclei will help the analyzer classify cells by the volume of their nuclei.

The measurement process

The analyzer is able to process human blood samples in open or closed sample vials. Closed tube mode is only available with certain vial types. The analyzer in Closed mode will only run a vial that has the cap on. Vials without caps are not processed.

Sample vials with caps are lowered into the sample disc that turns the vial upside down to allow small sample volume aspiration. The vial is pushed onto a fixed metal sampling needle and is pierced in the upside-down position. The fixed needle is equipped with a washing head to clean the needle's external and internal surfaces.

Sample vials without caps can be run in open tube sampling mode. The open sampling takes place via a retractable, flexible sampling tip equipped with a wash head. The wash head cleans the outside of the sampling tip and aspirates excess blood. The internal and external surfaces of the sampling tip are washed after every open tube sampling process. During normal operation, the flexible sampling tip is retracted into the analyzer.

The sampling system takes a total of 13 μl (open sampling mode) or 38 μl (closed sampling mode) of blood, 2.5 μl of which is used for the measurement. After closed sampling, the sample vial is returned and ejected in the top of the vial holder.

A ceramic shear valve guarantees precise sampling volume. The 2.5 μl of blood is mixed with isotonic diluent to create a dilution of approximately 1:200 dilution rate (primary dilution). Less than 3 μl of this primary dilution is used to create another dilution to the final dilution rate of 1:20000 (secondary dilution) using the same isotonic diluent.

The rest of the primary dilution is mixed with cyanide-free hemolyzing reagent and aspirated into the WBC syringe. The secondary dilution is aspirated into the RBC syringe.

The syringes are using air bubbles to homogenously mix the respective dilutions inside. Then a positive pressure (max 400mBar) is generated in both syringes and measurements start. The positive pressure forces both dilutions through their respective measuring heads composed of apertures of 70µm and 100µm for the RBC/PLT and WBC counts, respectively.

The lysed WBC solution prior to entering the measuring aperture passes through a microfluidic flow cell and is measured for HGB content at 540nm wavelength.

The cell counts are read simultaneously in the two channels along with a parallel HGB measurement. The entire cell counting and HGB measuring process takes 8 seconds.

HGB blank is measured and evaluated during every sample. Hemolyzer 3 NG does not use a separate HGB background measurement as a blank value. This allows a more precise live tracking of performance.

As a final step, the system empties the measuring elements and is ready to take the consecutive sample.

Supported blood collection tubes

Hemolyzer 3 NG can process human whole blood samples from open or closed sample vials.

Hemolyzer 3 NG's closed tube mode supports the following closed sample vials:

Type, Manufacturer	Minimum sample volume
BD Vacutainer (Ø13x75 mm) or compatible	400 µL
Greiner Vacuette (Ø13x75 mm) or compatible	400 µL
BD MAP vials or compatible	250 µL

Please consult the Instructions for use of relevant primary sample tube types.

	<p>WARNING</p> <p>Pierceable vial caps are designed for a limited number of penetrations with a needle. Using a closed vial more than 5 times without removing it from the sample rotor of Hemolyzer 3 NG poses a risk of damaging the rubber cap and causing liquid damage or clogging in the analyzer.</p>
---	---

Hemolyzer 3 NG's open tube sampling supports any whole human blood collected in sample vials prefilled with potassium-EDTA or prepared accordingly.

Hemolyzer 3 NG's retractable flexible sampling tip allows using a wide size range of sample collection devices. The minimum blood sample volume to achieve reliable sampling is 100 µL.

Samples must be mixed/homogenized adhering to general blood sample collection guidelines prior to analyzing them on Hemolyzer 3 NG.

Refer to section ***Blood samples*** later in this manual.

Package contents

Hemolyzer 3 NG comes in a double cardboard packaging. The outer box provides a protection against shipping damage to the analyzer's internal box.

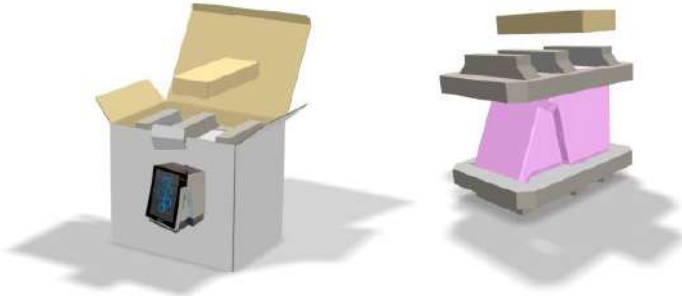

The internal box contains the analyzer and its accessories inside protective foams. The analyzer comes with a protective film covering the scratch resistant polycarbonate cover elements.

Upon arrival, carefully check the contents of the package and look for visible damages, even on the outer packaging box. File any obvious damage through the shipping company to be eligible for compensation and support from your local dealer and from the manufacturer.

Packing list:

- Analyzer outer packaging box and shipping foams (top, bottom)
- Accessories box
 - o Power supply; Power cord
- Reagent tubing set
 - o Black cap cleaning vials
- Documents and Guides
 - o Quick Guide
 - o Reagent Connector Guide
 - o Installation Report
- Analyzer packaging bag
- Hemolyzer 3 NG analyzer

Accessories

- external power supply
SYS1443-6512-T3 or SYS1548-6512-T3
- **grounded** power cord matching your standard power outlets
- reagent pickup tube set in a plastic bag:
 - reagent connector
 - tubing
 - caps for various reagent setup
 - draining tube kit
 - black cap cleaning vials
 - Reagent Connector Guide



Always use original accessories and cables.

Non-approved electronic accessories may damage the system and can result in electric shock.

Identifying parts of the analyzer

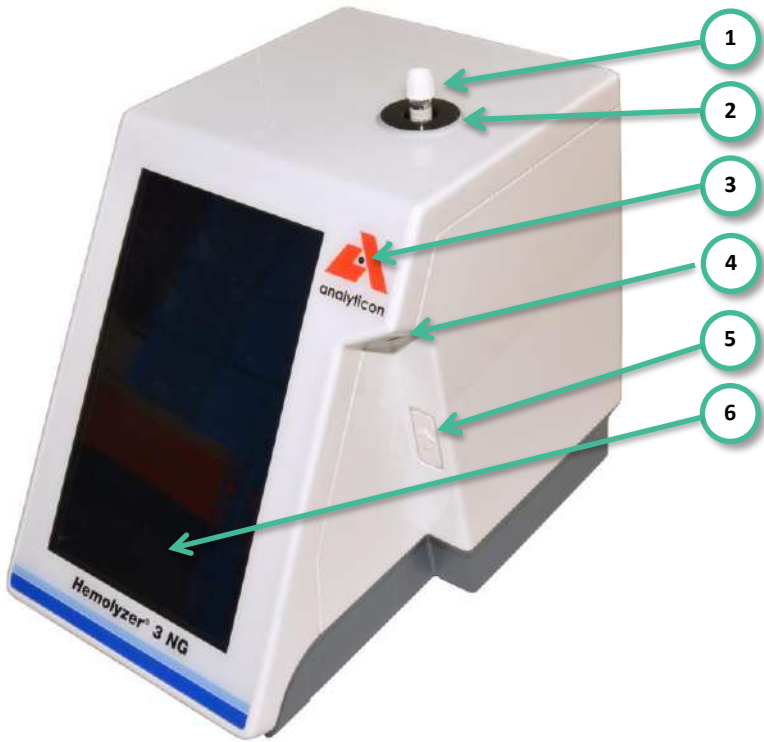

Front and right side of Hemolyzer 3 NG

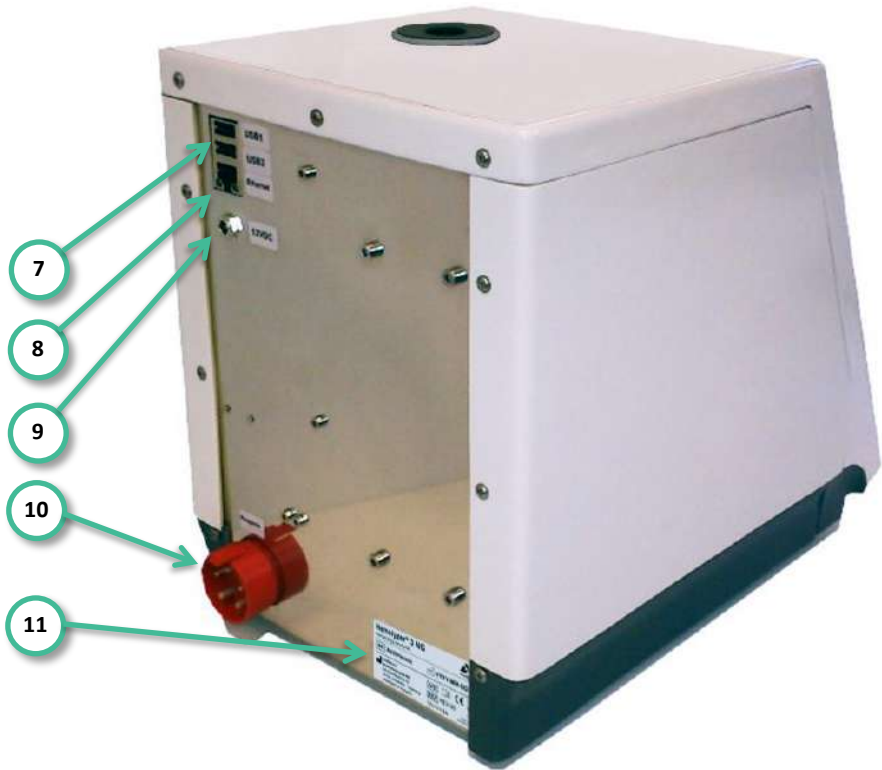

1. Sample vial with cap
2. Status indicator ring
3. Front camera (in the middle of character O)
4. Opening for open tube sampling tip (retracted)
5. POWER/START button
6. Display with touch screen



Rear and left side of Hemolyzer 3 NG

7. USB connectors
8. RJ45 (network) connector
9. Power connector (12V DC input)
10. Reagent connector
11. ID label of analyzer with S/N and electrical data



Installing the analyzer

	Hemolyzer 3 NG is a precision hematology analyzer. Incorrect handling or accidental falling of the analyzer may damage parts inside and could influence performance.
	To avoid overheating of the device, avoid installation in confined space. If the system detects overheating, safety functions will disable operation. Ambient temperature being above 34°C (86°F) for an extended time may cause the system over-heat.

1. Carefully remove Hemolyzer 3 NG from the shipping carton. Look for signs of damage, such as cracks on the outer covers or loose/missing screws. If you find such signs, please file a complaint to the shipping company to be eligible for compensation and support from your local dealer and from the manufacturer. Make sure you can find all the accessories listed in the packing list.
2. Prior to powering on Hemolyzer 3 NG, allow the analyzer to reach room temperature to avoid dew condensation. Sudden temperature changes may cause dew to condensate on colder internal structures and can lead to damage of electronic components.
3. Place the analyzer on a desktop bench and find a nearby **grounded power outlet**. Please avoid power extension cords, use direct connection to the power outlet. Always use the power supply packaged along with the analyzer.
4. Connect the power supply to the socket on the rear plate of the analyzer.
5. Connect the power cord to the power outlet.
6. Remove the protective foil from the analyzer's front.

	<p>Attention</p> <p>If you experience any error, like smoke, immediately disconnect the power cord from the power outlet.</p> <p>Use a fire extinguisher if necessary.</p>
---	---

User serviceable parts

	<p>Attention</p> <p>There are no user serviceable parts inside the analyzer. Please do not attempt to open or disassemble the analyzer to avoid electric shock or injury and will void the warranty.</p>
	<p>Attention</p> <p>Only qualified Service Personnel are allowed to perform adjustment and repair procedures related to internal components.</p>

Connecting peripheral devices

Hemolyzer 3 NG offers 2 USB sockets for connecting external peripheral devices. To expand USB connectivity options, you can connect any standard USB HUB.

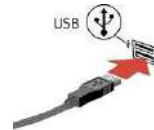

Keyboard (optional)

Hemolyzer 3 NG supports connecting external USB keyboards that can facilitate data entry. The keyboard can be connected any time.



Mouse (optional)

Hemolyzer 3 NG supports connecting a USB mouse. The mouse can be connected any time. If a mouse is connected, the touch screen remains operating, yet a small arrow icon will be displayed to track the movement of the mouse.



Bar code scanner (optional)

You can connect a USB bar code scanner.



USB flash drive (optional)

You can connect a USB flash drive to save reports, archive settings and database content. The USB flash drive is also suitable to review and import data stored externally.

The USB devices should use FAT32 file system to be compatible with Hemolyzer 3 NG.



USB Wi-Fi Dongle (optional)

The device offers connectivity options to wireless networks (sending measurement reports via email). Network settings must be revised. The analyzer software supports a limited number of Wi-Fi dongles.



Attention

It is not guaranteed that any random Wi-Fi dongle will work with the analyzer.

Supported models:

- AmbiCom WL250N-USB (Chipset: Ralink RT3070)
- EnGenius EUB9707 USB Wi-Fi adapter
- LM Technologies – LM006

Network (“Ethernet”)

Connect the cable (not included) from the computer network to Hemolyzer 3 NG’s RJ45 socket. Network settings must be revised.



Reagent pack

The Analyticon Hemolyzer 3 NG reagent pack provides sufficient reagent to run a specified number of tests with Hemolyzer 3 NG. The pack contains all necessary reagents.

Waste bottle is not included.



Hematology reagent waste must be considered biohazard material. Always follow local regulations regarding disposal of used consumables, and reagent.

Reagent bottles

Analyticon Hemolyzer 3 NG is also suitable to run using individual reagents, external reagent containers, bottles. Care must be taken when connecting reagent bottles to the system. Always pay attention to match the right line with the correct reagent. It is possible to shorten the tubes as necessary.

Assemble the reagent bottle caps following the sketch below:

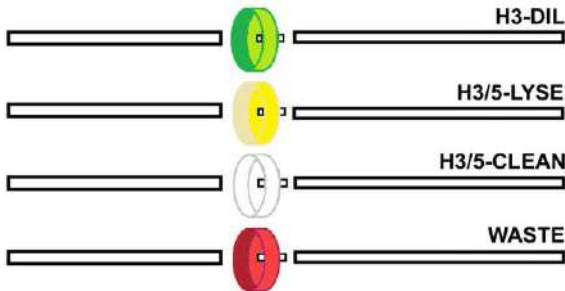

Each tube is equipped with a label indication which bottle to connect it to. The caps will match the standard Hemolyzer 3 NG reagent bottles.

Rear view (from tube side) of the reagent connector:

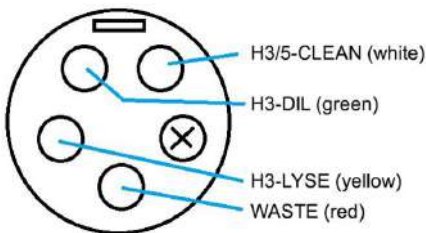

Attention

For best results and performance, place the reagents to the same level (on the same desk) as the analyzer.

Analyzer packaging material

Retain the packaging for return and storage.

Power

External power supply

Hemolyzer 3 NG can only be used with the supplied external power supply. The power supply generates 12 VDC required for operation of the analyzer.



The power supply is able to operate between 90-264 VAC @ 47-63Hz. No setting is required for input voltage selection. The power supply has standard input and output connectors.

Upon connecting the power supply, Hemolyzer 3 NG is in low power consumption mode and ready for operation.



Always use a grounded power outlet to avoid the risk of an electric shock, and to ensure reliable operation.

An unearthed power outlet may make the analyzer sensitive to external electrical interferences and may impair operation.

Power button

It is located on the right side of the beveled front panel. When the external power supply is connected both to the analyzer and to the mains outlet, the analyzer can be turned on by pushing the START button.



Power on

The single push of the START button will power on the electronics and Hemolyzer 3 NG will display the welcome screen and the main menu automatically.



When Hemolyzer 3 NG is turned on, the screen remains dark, only backlight illumination can be seen at the edges of the screen. This is normal. After a few moments Hemolyzer 3 NG will show the welcome screen and load the SW when it is ready the main menu will appear.

Power off

Hemolyzer 3 NG is a sensitive device with liquids inside. A simple power off might leave the system in a state that can represent potential risk to moving components and liquids inside.

Therefore, Hemolyzer 3 NG has a programmed power off sequence. It is recommended to always follow the programmed power off sequence to avoid unreliable operation of the structures inside the analyzer.

Hemolyzer 3 NG can be turned off by holding any point of the screen for 3 seconds and initiating Shutdown in the submenu. To power off the analyzer, select "Shutdown". The automatic process will start, and the analyzer is safely powered off within 30 seconds. Do not interrupt this sequence.



It is strongly recommended to power off the analyzer every day, at the end of the daily routine. This will save electricity and ensures that the analyzer operates reliably on a day to day basis.

Emergency power off

If necessary, Hemolyzer 3 NG can be powered off by holding the power button for 4 seconds. This method skips the preprogrammed Shutdown.

	<p>Performing an emergency power off can leave the analyzer in an undetermined state. Not operating the analyzer after emergency power off can result in malfunction.</p> <p>Please contact your maintenance personnel to avoid damage to internal components.</p>
---	--

To completely and immediately power down Hemolyzer 3 NG, remove the power cord plug from the mains outlet or the power connector from the back of the analyzer.



Handling reagents

Hemolyzer 3 NG operates with special reagents. The reagents have been carefully designed to meet the requirements of the analyzer. Hemolyzer 3 NG's quality assurance system requires the use of these special reagents. Hemolyzer 3 NG recognizes and accepts genuine reagents only.

Reagents are sensitive substances and as such require careful handling.

Precautions about reagents

Reagents are considered chemicals and do arrive along with respective package inserts and MSDS. Always follow instructions of the reagents concerning reagent handling.

	<p>It is recommended to wear protective gloves when installing and replacing reagents to avoid contaminating reagent tubes immersed into the reagent bottles.</p>
	<p>Always rinse reagent tubes at first installation using clean water to avoid contamination of reagents. After rinsing, wipe the outside of the tubes to be immersed using clean, lint-free tissues.</p>

Reagent characteristics

Hemolyzer 3 NG's original reagents do not contain any environmentally hazardous substances.

Blood samples

Hemolyzer 3 NG is able to process whole blood human samples.

Proper handling of a hematology sample is of key importance for accurate, dependable and reproducible results. Blood is a living tissue composed of cellular structures suspended in liquid plasma. The cellular structures are composed of cell membranes with liquid and intracellular structures inside. Hematology analyzers are designed to detect, calculate and classify these cellular bodies and their content. As the cells are actually alive in the meaning of active chemical interaction with their environment, keeping them close to their ideal environmental conditions is important for correct analysis. Blood samples intended to be analyzed for hematology purposes are sensitive to temperature, anticoagulant quantity and quality, and mechanical effects.

Follow the guidelines below for optimal sample handling.

Taking the sample

Collect venous blood using (preferably K2- or K3-EDTA-prefilled vacutainer; 1.5-2.2mg/ml) anticoagulant collection tube.

Hematology sampling tubes have the anti-coagulant prepared inside the vial in the form of liquid or gel. To ensure the correct amount of blood that can be treated with the pre-dosed anti-coagulant, sample vials are shipped with vacuum inside that ensures aspiration of the right amount of blood during the original sampling process.

Sample vials also have a mark indicating the optimal sample level for the anti-coagulant already included in the sample vial.



An EDTA quantity below or above the recommended ratio will cause false or no results due to improper chemical treatment of blood cells.

Rapidly and thoroughly mix the blood with the anticoagulant; do NOT shake the vial for mixing. The anticoagulant requires approximately 15 minutes for taking its required effect on the sample. Running the sample within the reaction time of the anticoagulant may result in false cell counts and improper differential results.

Transporting and storing samples

For best results, blood samples must be run within 8 hours from venipuncture if stored at room temperature.

- Samples should be stored upright at room temperature for not more than 12 hours.
- If samples need to be transported after collection, provide a cooled environment (2-8°C).
- Hematology blood samples must not freeze. Avoid direct contact of sample containers and cooling agent (cold surface, ice pack, etc.).
- Samples can be stored refrigerated (between 2-8°C) for not more than 24 hours prior to analysis.

Sample age

To get the best WBC differential results, samples should be analyzed between **15 minutes and 8 hours** after blood taking. This time period **can be extended up to 24 hours**, if samples are kept refrigerated **between 2-8°C**.

- If a sample is kept refrigerated, remove it from the fridge, and **let it rest at room temperature for at least 15 minutes** before analysis. Measuring cold sample may affect WBC differential results.

Analyzing samples beyond 24 hours after taking is not recommended.

Preparation for analysis

Follow these guidelines for best performance.



- **Do not place samples on rockers/homogenizers, because it may negatively affect WBC differential results.**
- Sample temperature must be between 15-28°C. Lower temperatures will interfere with homogenization, higher temperature may induce faster degradation of cells.
- Samples must reach room temperature in a natural manner. Do not heat or directly warm the vials not even by holding them in your palm.
- Samples must not be mixed while cold. Doing so may physically damage the cells. Let the vials stand in their holder upright for 15 minutes before running them on the analyzer.

Proper Sample Mixing prior to run

Samples must be **homogenized** prior to analysis by **5-7 inversions** of the vial.

Follow the steps below:

1. Tilt the tube carefully **looking for clots** in the sample – if clot found refuse the sample from analysis.
2. Invert the tube: turn it upside down, allow the blood flow over completely (1-2 seconds), then turn it back.
3. Repeat tube inversion another 5-6 times.
4. Run the sample immediately.
5. If you want to rerun a sample within a few minutes, invert the sample tube just once, and initiate sampling.

	<p>Do not shake or drop the vial, this will form bubbles inside. Do not apply vortex mixing.</p>
	<p>Do not place samples on rockers/homogenizers, because it may negatively affect WBC differential results.</p>

Important factors for sample handling:

1. Running too fresh samples – taken in **15 minutes** – may affect WBC differential results. Wait 15 minutes before analysis.
2. **Analyzing a sample without homogenization will result in an incorrect report.** The analyzer has no sensor to detect lack of homogenization.
3. **Do not use an automatic sample mixer/rocker**, since it applies mechanical stress to the cells continuously which may negatively affect WBC differential results. For the same reason, **do not invert the sample tube more than 7 times**. Vigorous mechanical mixing weakens cell membrane, especially NEU cells are sensitive to mechanical mixing.
4. **Doing less than 4 inversions may leave the sample in a non-homogenous state.**
5. If a sample is kept refrigerated **let it rest at room temperature** for at least **for 15 minutes** before analysis. Measuring cold sample will affect WBC differential results.

Bubbles in sample

If bubbles are present in a sample, the amount of actual sample processed by the analyzer may be less than required, and the analyzer may falsely report incorrect values.

- Such sample should relax for 10 minutes before analyzing it.

Sample handling



Blood samples must always be considered as biohazardous and infectious biological material.

It is recommended to wear protective gloves and goggles.

Spilled blood must be cleaned up as soon as possible, and the surface it got in contact with must be cleaned with a suitable sanitizer. Same applies to blood dried onto surfaces. Always wear protective gear even when you are cleaning dry blood from surfaces.

Menu system

The screen area

Hemolyzer 3 NG's information display screen can be divided into four areas:

1. **Status bar**
Displays active menu and instrument status
2. **Page count area**
(appears if left-right swipe is available)
3. **Main information**
Displays further functions available related to displayed data
4. **Quick links**
Displays further functions available related to displayed data



Menu tree

Daily routine	Sampling	Run open or closed tube samples, Calibration, QC, FastBlank
	Results	Database functions

Management	Maintenance	Prime & Drain, Clean, Diagnose, General
	Service	Service Personnel Only



Reagents	Pack	Pack usage
	Individual	Individual reagent containers, usage

Options	System settings	Date / E-mail / Printout / Printout Formats / Network Printing / Customization / Patient Profiles / LIS
	Customize	Language / Units / General settings

System	History	Operation log
	About	Product info / Hardware info / SW upgrade / Database records deletion

Gestures

Hemolyzer 3 NG's touch screen user interface allows operating the analyzer with light taps and swipe actions listed below.

	Taps (quick touch and release over a certain point)
	Hold (touching a certain point and holding your finger there for 2-3 seconds before releasing it)
	Swipe (quickly moving your finger along the screen without lifting it)

All actions (touch, hold and release) are acknowledged by a small circular symbol appearing at the point where the user tapped the screen, and an audible beep is heard if sound was enabled.

Using the above basic actions, Hemolyzer 3 NG can interpret various combined actions, so-called gestures.

Tap

Touching (tapping) an active area (icon, data input field) will activate the corresponding function, or open a sub-menu. For data input fields, an on-screen keyboard is displayed at the top or bottom quarter of the screen depending on the position of the data input field.

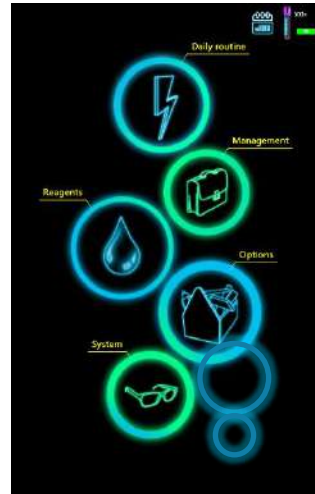

Swipe

Hemolyzer 3 NG is able to display data that spans over several screens (pages). Such pages are indicated with small rectangles in the center near the top half of the screen.

To switch (scroll) between such screens, you need to perform a sweeping gesture by lightly touching the screen at any point of the screen showing data, and quickly sweep your finger in the direction of the intended scrolling action (up, down, left, right). The screen will be scrolled in the requested direction.

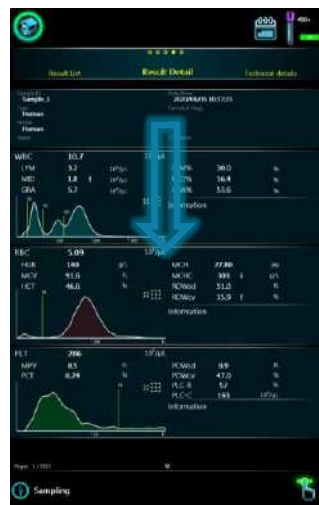

Hold

To access functions related a specific area, or to access special functions, you can touch and hold a specific point on the screen. This action will trigger displaying special local menus offering services related to the contents of the screen.

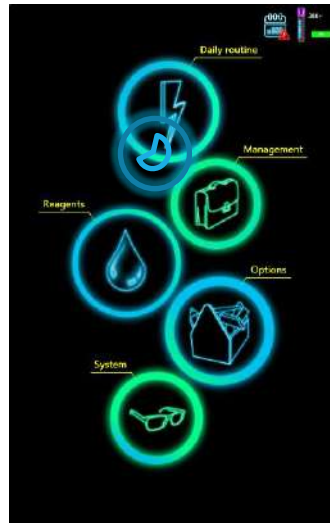

On-screen keyboard

When you select to enter data, an on-screen keyboard will be displayed at the top or the bottom quarter of the screen. The position of the keyboard depends on the position of the data input field to avoid covering the field with the keyboard.



Data input

Alphanumeric input

Input fields are marked with an underscore. Tapping into any field allows editing data. The on-screen keyboard will be displayed either in the top or in the bottom quarter of the screen to make sure that the input field remains visible.



The cursor is indicated by a light underscore below the character.

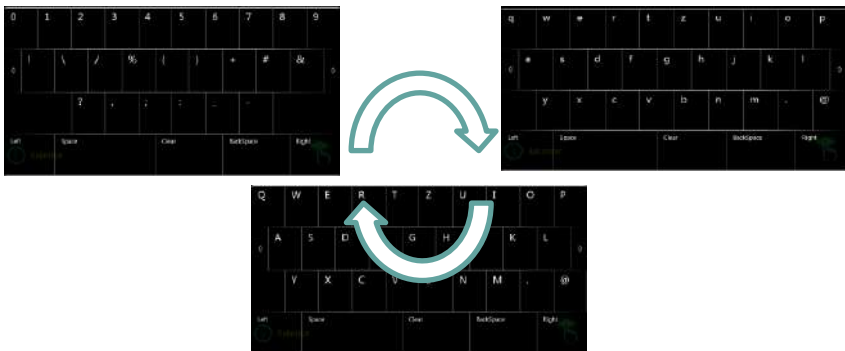

The on-screen keyboard allows changing symbols entered by changing the keys. The keyboard can be changed by swiping left or right to reveal capital letters, small letters and symbols.

SPACE adds a space at the cursor.

CLEAR deletes the **entire** field.

BACKSPACE erases the character left of the cursor.

External keyboard

If an external keyboard is connected to Hemolyzer 3 NG, then keystrokes from the external keyboard will be used to enter data into input fields. Always the English keyboard layout is used to interpret keystrokes.

Barcode input

If an external barcode scanner is connected, then the read ID will be entered as Sample ID for the consecutive measurement.

This function is only active if the measurement function is activated. Barcode scanner data will not be interpreted as data for any other field.

To input barcodes:

- Make sure the analyzer is measurement mode (ready to start)
- scan the barcode with the handheld scanner

When a barcode has been recognized and interpreted, the bar-code will be entered into the Sample ID input field.

Numeric input

















Some data fields may require modification on a larger scale. For this purpose, Hemolyzer 3 NG offers another intuitive setting method.



















Sampling type	Auto Calibration			Manual Calibration		
WBC ✓ 7.70 $10^9/\mu\text{L}$	---	--	-	+	++	+++
RBC ✓ 4.83 $10^6/\mu\text{L}$	---	--	-	+	++	+++









Symbols ---, -- and - buttons will have decreasing effect on first, second and the third digit, respectively.

Symbols +, ++ and +++ buttons will have increasing effect on first, second and the third digit, respectively.

Description of icons displayed

	[Daily routine] Access measurement mode and results
	[Management] Access point of maintenance functions
	[Reagents] Reagent menu
	[Options] Settings
	[System] System administration utilities
	[Home] Back to the Main menu
	[WiFi] Wi-Fi network available
	[WiFi] Wi-Fi network connected
	[ETH] Wired network available
	[PrinterThermal] Thermal Printer connected
	[PrinterPCL] PCL5/PCL6 Printer connected
	[Printer] Unknown Printer connected
	[Loading...] The analyzer is busy
	[QuestionMark] Measurement mode selection
	[Gift] New results are available
	[Vial] Available measurements in the pack.
	[E-mail] Send selected records in an email.

	[TSF] Save records into TXT file (Tab Separated File)
	[PDF] Save selected results into PDF file
	[LIS] Send results to LIS
	[Uncheck] Check/uncheck selected elements.
	[Drop] Discard elements
	[Reset/Load] Reset to original or default values./ Load data from external USB drive
	[Accept] Confirm and accept elements
	[Print] Print selected records
	[Eject] Remove tube from sampling rotor
	[Read] Read (scan) QR code
	[SelectionStart] Activates multi-selection
	[SameDay] Selects records of a specific date
	[SameSampleID] Selects records of a specific SampleID
	[CV] Calculate CV of selected results
	[Jump] Jumps to given date in records database
	[LoadW] Load wallpaper
	[SaveRAW] Save raw measurement data
	[ShutDown] Initiates shutdown sequence

 Back	[ClosePage] Closes context menu
 ER Mode	[ERMode] Activates ER mode
 Admin Mode	[AdminMode] Deactivates ER mode
 Calibrate	[Calibrate] Loads mean of parameters as calibration target (selected records)
 Load Profiles	[LoadProfiles] Load Profiles
 Save Profiles	[SaveProfiles] Save Profiles
 Alarm Clock	[AlarmClock] Automatic timer for specific actions is on. Tap for details.
 Full	[Full] External liquid container is full. Tap for details.
 Unsent	[Unsent] There are unsent records in the message queue (network error)

Setup

Hemolyzer 3 NG comes preprogrammed with the operating software, and has most its options set to standard values, values that suits most laboratories.

However, you can customize these settings to make Hemolyzer 3 NG fit into your daily routine even better. Here is a brief list of options that you are recommended to adjust or verify to make the use of the analyzer simple and convenient.

Initial setup

Below is a recommended sequence of settings so that you can start using the analyzer easily:

- choose a language for your analyzer
- practice gestures used on the screen
- set time and date
- set up your Laboratory information and measurement units
- set up your network and connectivity (email) (if available)

At the first startup a practice wizard starts where you can practice the usage of analyzer (gestures, setting changes) and adjust date and time. You can skip each stage; you can leave the setup wizard at any time. You can also (re)run the wizard at any time later on.

Language

Hemolyzer 3 NG software supports various languages. The default is English. To change:



→ [Customize] → (Page 2)

The second page of Options/Exterior will display the list of available languages. Tap the checkbox to the right of the preferred language. All text displayed will immediately be changed to the new language. Your changes are immediately saved.

Time and date

Set time and date.



→ [System Settings] → (Page 1)

Your changes are immediately saved.

Laboratory specific information (printout contents)



→ [System Settings] → (Page 3)

Set the name of your laboratory or the text you want to appear on reports generated by Hemolyzer 3 NG.

Your changes are immediately saved.

Report output (email)

Hemolyzer 3 NG can produce reports ready to print and can send them to any recipient you defined.



→ [System Settings] → (Page 2)

You can also choose to create and print reports locally. For this, you need to connect Hemolyzer 3 NG's dedicated thermal printer or a PCL5/PCL6 printer (via network also supported).

Settings – Customize

Appearance

[Page1]

You can disable the visual feedback of touchscreen gestures.

You can enable/disable audible touch feedback.

You can change the background image.

To use Custom wallpaper, use “Custom” setting, and load your wallpaper by accessing local menu (tap-hold screen) and tapping the “Load Wallpaper” icon.

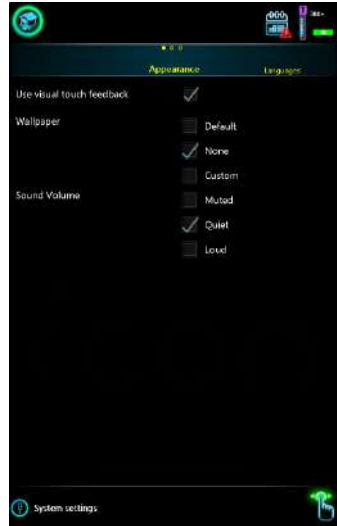

The wallpaper file must reside on a USB memory device, named “CustomWallpaper.png”. Resolution must be 800x1280 pixels. Do not use clear white or clear yellow images: this will impair screen readability.



Hemolyzer 3 NG will confirm the new wallpaper file or will display an error message if the image is not of the right size, format, or it cannot be found in the root folder of the USB memory device.

Languages

[Page2]

Language of the user interface can be changes. Changes have an immediate effect.



Units

[Page3]

It also allows changing measurement units for cell count (WBC, RBC, PLT), HGB, HCT/PCT.



System Settings

This menu allows setting operation related parameters.

Date and time

[Page1]

This menu allows changing the current date and time by pressing Done button.

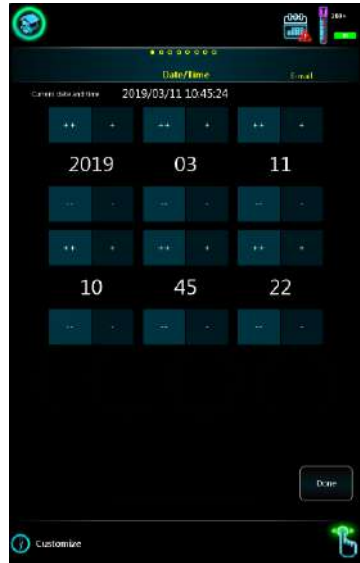

Email settings

[Page2]

This screen provides fields to set e-mail account parameters used for reporting:

- "Email to": Default "To:" address
- Sender e-mail address ("From:")
- "From:" email account password

It is necessary to define SMTP settings (default provider is Google because of compatibility issues).

For details, please consult your email provider. Gmail may require enabling "less secure apps" to allow the device to manage emails.



Some examples:

- Yahoo: smtp.mail.yahoo.com; 465 port; SSL
- Google: smtp.gmail.com; 465 port; SSL
- Office365: smtp.office365.com; 587 port; STARTTLS

It is possible to choose to automatically generate and email the report in PDF format.

Test the e-mail settings by tapping the “Test E-mail settings” button.

Network preferences

Hemolyzer 3 NG allows connection to networks over Wi-Fi or cable. Some processes may fail if they start communication over the wrong interface.

Access **Local Menu** (tap-hold screen) on **Email settings page** to change Network preferences setting.

It is possible to choose which interface (WIFI/Ethernet) to use for various activities:

- Remote Access
- Email transmission
- LIS transmission
- Network printing

Preferences can only be applied if both wired and wireless networks are available.

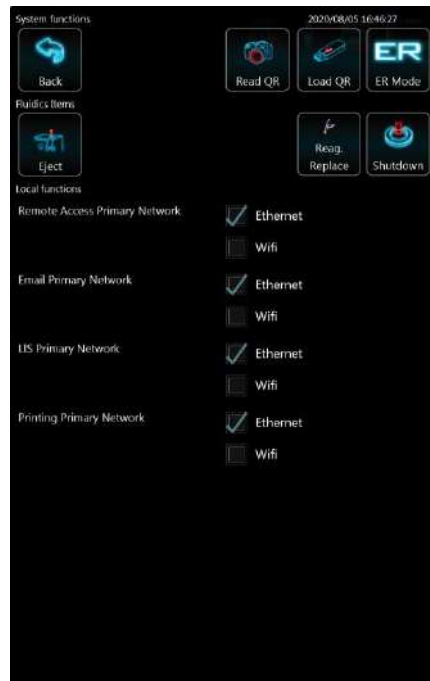

Printout Settings

[Page3]

There is a possibility to define some standard messages or comments to be included in a report generated by the analyzer.

It is possible to enter a header composed of 5 lines that will be printed on all reports. These five lines can be left, center or right aligned.

Enabling “AutoPrint” will make Hemolyzer 3 NG print reports after the results are available. (Requires connection of a printer)

Hemolyzer 3 NG can use ESC/POS language for unrecognized printers.

Defining printout signature(s) will make Hemolyzer 3 NG print line(s) with the defined value(s) on the bottom of page.

(Signature’s visibility on A4 formats depends on corresponding setting.)

Hemolyzer 3 NG can be forced to use ESP/POS language for unrecognized printers.

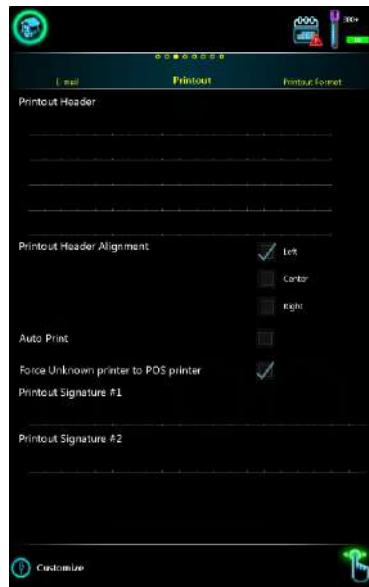

WARNING

Forcing an incorrect language to a printer may result in scrambled printouts, and empty pages, even one single symbol per page!

Printout Format

[Page4]

It is possible to choose between 4 different printout formats.

Select which parameters you want to appear on the printout, and the order of appearance can also be customized.

Note: parameters cannot be moved within parameter groups. Parameter groups are separated by horizontal lines.

It can be chosen whether you want the PDF reports to be colored or not, hide histograms, hide technical flags, print the technical data and show or not the signatures on the printout.



Color output is available for PDF, color printing depends on printer and its driver capabilities (PCL6).

HEADER	
Informations	
WBC histo	WBC flags
RBC histo	RBC flags
PLT histo	PLT flags
Technical flags	
Technical data	
Signature #1	Signature #2
FOOTER	

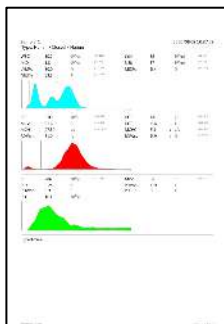

HEADER	
Informations	
WBC histo	
RBC histo	
PLT histo	
WBC flags	
RBC flags	
PLT flags	
Technical flags	
Technical data	
Signature #1	Signature #2
FOOTER	

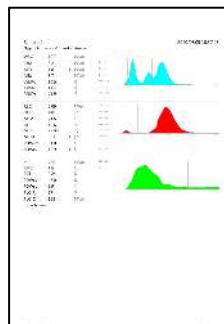

HEADER	
Informations	
WBC histo	RBC histo
WBC flags	RBC flags
PLT histo	PLT flags
Technical flags	
Technical data	
Signature #1	Signature #2
FOOTER	

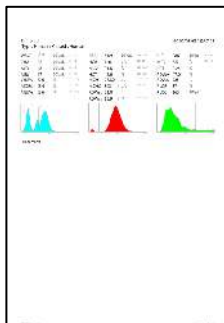

HEADER	
Informations	
WBC histo	
RBC histo	
PLT histo	
WBC flags	
RBC flags	
PLT flags	
Technical flags	
Technical data	
Signature #1	Signature #2
FOOTER	

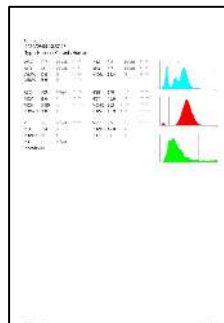

Network Printing

[Page5]

It is possible to use a **network printer** as a default printer – define the IP address and Port (consult your system administrator or printer manual for details) of the printer.

Select PCL5 or PCL6 language. Only these languages are available for network printing.

When all settings are made, you can print a Test page to verify the setup.



	<p>WARNING</p> <p>Forcing an incorrect language to a printer may result in scrambled printouts, and empty pages, even one single symbol per page!</p> <p>An incompatible printer may not even react to wrong messages, this way you get no feedback about the incompatibility.</p>
--	---

It is possible to use Print server (PrintServer software is available from Analyticon) as a default printer. For more information, consult your distributor.

PrintServer allows the analyzer to use a remote PC (running Windows) and its connected printer to print reports. You need to define the IP address and Port (consult your system administrator) of the PC running the Print Server.

When all settings are made, test page can be printed to verify the setup.

Customization

[Page6]

Defining Comment 1-3 values will change header of comment fields on printouts and user interface as well.

QC charts include only 9 parameters (WBC, LYM%, MID%, GRA%, RBC, HGB, MCV, PLT ,MPV) if Short QC parameters mode is selected.

Used Reagent volume: you can define the volume (in Liters) of the external container collecting waste liquid. When the free volume drops below 0.3L, there will be a Full container symbol in the upper right corner of the screen. If you set 0 as volume, Hemolyzer 3 NG will not display a warning at all.

Enabling QC measurement warning allows the system to pop up a message about QC measurement importance after every daily startup.

Enabling Interpretation flagging option shows current interpretation flags for results (screen, printouts).



Profiles

[Page7]

Minimum and maximum values can be set for each measured parameters. Measured values will be verified against these limits.

Hemolyzer 3 NG offers 8 slots (Human, Male, Female, Profile 4-8). Swap between profiles by swiping up/down.

All limits can be changed. You can define custom names for Profile 4-8.

To backup/restore Profiles tap the “Load Profiles” or “Save Profiles” icon by accessing local menu (tap-hold screen).

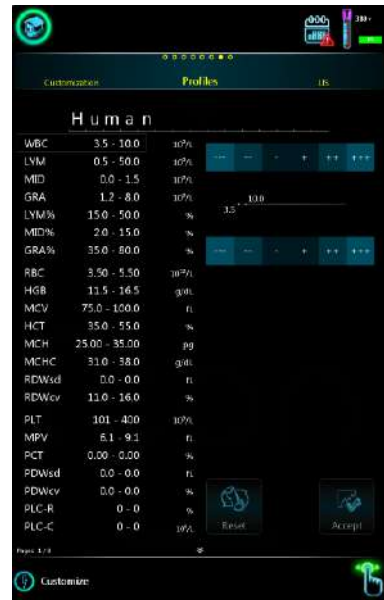

LIS (Laboratory Information System)

[Page8]

Hemolyzer 3 NG is capable of transmitting reports using HL7 v2.5 protocol to a host computer.

This page allows setting HL7 server IP address along with the communication port.

Automatic transmission of results can be enabled.

By enabling repeating of Sample ID as Patient ID the transmitting report will contain standard HL7 PID field which includes the sample identification string.

Keeping HL7 connection open after transmission can be enabled.

HL7 message format is depends on selected version. For more information requests for HL7 transmission protocol document.

This page also allows setting up Remote Access parameters. For details, please contact your Service Personnel.

With LIS resend option you can set when the software could resend unsent LIS messages (in every 1/4/24 hours or never).

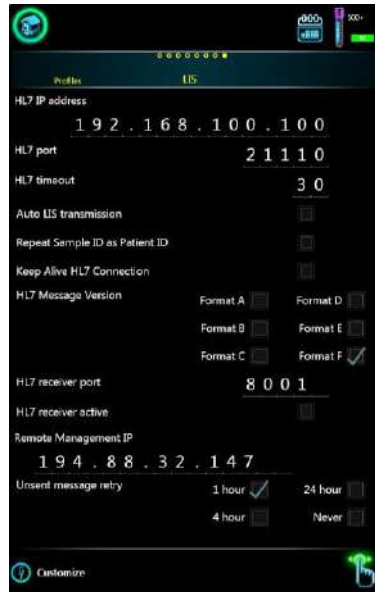

Measurement Settings

The detector used for sample detection in open mode close to its operation limits below $HGB = 45 \text{ g/L}$. A very thin (low HGB) sample or a sample without particles (not blood) can trigger this warning. To avoid these limitations, you can disable the open mode sample (blood) sensor.

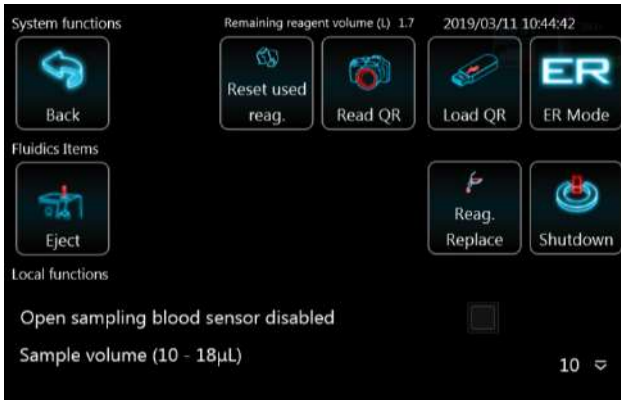

This way the system will use a preset volume of sample travel and will not use sample sensor. The disabled OPEN sample detector is marked with red highlighted BS (Blood Sensor) symbol on the top of the screen.

Setting up reagents

Hemolyzer 3 NG requires reagents to run. Connected reagents can be managed from the Reagents menu. Reagents menu has two separate branches: one for packed and one for individual (“Bulk”) reagents.

Reagent: Pack

Tap on the Reagent icon in the main menu then select “Pack”.



A list of reagent pack will be displayed. The active (currently used) pack will have a green background. Inactive packs have no coloring, expired or empty packs will have a dark red background.

Swiping left on a row will bring up detailed information about the pack: LOT number, expiration, part (ordering) number, and level of the pack with consumption data, open bottle stability data (based on installation date) and usage statistics.

Tap and hold any area of the screen to display the local menu when reagent data are displayed. Tap the “Deactivate” icon to stop using a pack. Tap the “Activate” icon to start using a pack.



To add reagent packs to the system:

Hemolyzer 3 NG offers entering reagent pack data using the onboard camera. Analyticon provides reagent packs with QR codes.

To activate QR code reading sequence:

- tap and hold any point on the screen.
- tap the small camera icon. “Read QR”

The screen will change, and you will see a live image of what the camera “sees”. The camera is located in the center of the letter “o” in the “Icon” text at the top right corner of the front panel.



Hold the QR code in front of the analyzer, making sure that the code is not curved or bent. The QR code should be located in the center of the live image. The camera has a fixed focus find the best distance to read the QR.

Hemolyzer 3 NG will acknowledge the QR code with an audible tone. The data will be entered as a new reagent pack. If you scanned a code that already exists, Hemolyzer 3 NG will show a message.

To load codes from a USB flash drive, use the “Load QR” icon.



Reagent: Individual Reagents

Tap on the “Reagent” icon in the main menu and then select “Individual Reagents”.

A list of individual reagents will be displayed.

You can see the details of actual reagents by tapping the row of a specific reagent. The active (currently used) reagent will have a green background. Inactive reagents have no coloring, expired or empty entries will have a dark red background.

Swiping left on a row will bring up detailed information about the reagent: LOT number, expiration, part (ordering) number, and level of the container with consumption data.

Important note: individual reagents can only be used if the 2nd and 3rd LOT number for all three bulk reagents (Diluent, Lyse, System Solution) are identical:

- 17 – reagents manufactured before September 2021.
- 14 – reagents manufactured from September 2021.

Mixing individual reagents is not possible and the analyzer may show an error message.

Tap and hold any area of the screen to display the local menu when reagent data are displayed. Tap the Deactivate icon to stop using a reagent container. Tap the Activate icon to (re-) start using a reagent container.

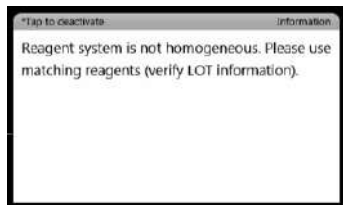
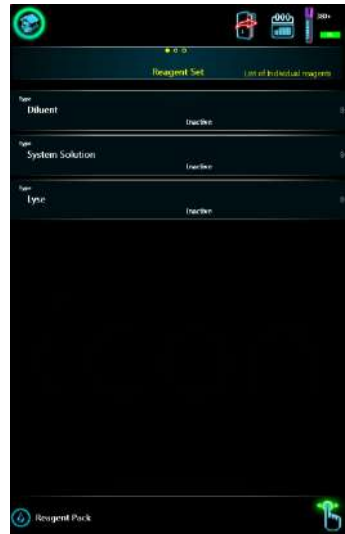

To add individual reagents to the system:

Hemolyzer 3 NG offers entering reagent data using the onboard camera. Analyticon provides individual reagents with QR codes.

To activate QR code reading sequence:

- tap and hold any point on the screen.
- tap the small camera icon.

The screen will change, and you will see a live image of what the camera “sees”. The camera is located in the center of the letter “o” in the “Icon” text at the top right corner of the front panel.

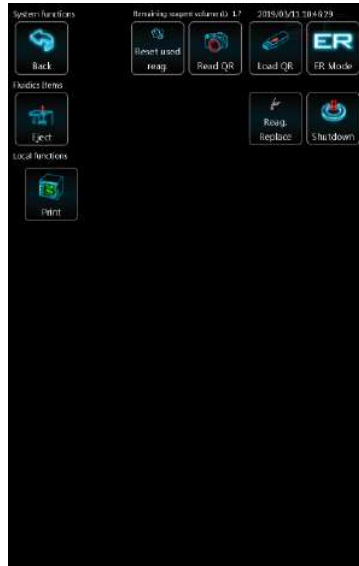

Hold the QR code in front of the analyzer, making sure that the code is not curved or bent. The QR code should be located in the center of the live image. The camera has a fixed focus find the best distance to read the QR.

Hemolyzer 3 NG will acknowledge the QR code with an audible tone. The data will be entered as a new reagent pack. If you scanned a code that already exists, Hemolyzer 3 NG will show a message.

To load codes from a USB flash drive, use the “Load” icon.



Manual QR code entry

In some cases, the QR code could be damaged. In this situation the user can enter the QR code data manually.

Activate local menu in reagent pack list menu or in diluent, lyse or system solution list menu.

Enter all data located around QR code into the corresponding data field.

After that tap the button below the data to confirm data.

The analyzer will not allow more than three false data entries. The analyzer must be restarted to try again.

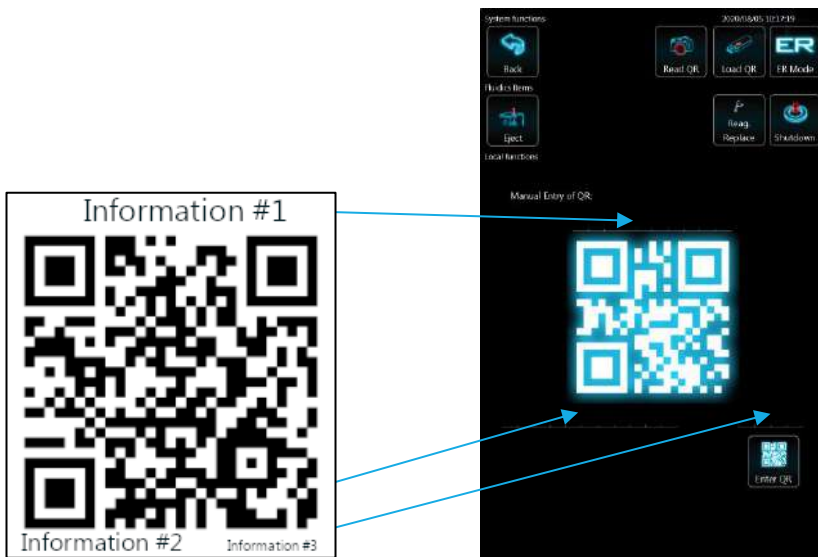

Network Settings

You can make the most of Hemolyzer 3 NG's services if you let it connect to a network with access to the Internet, so that it can create and send reports in emails, transmit data to your laboratory information system and update software when necessary.

Network availability is displayed in the top row of the screen.

When Wi-Fi is available (a USB Wi-Fi adapter is connected) then a little signal strength icon appears in the top row.

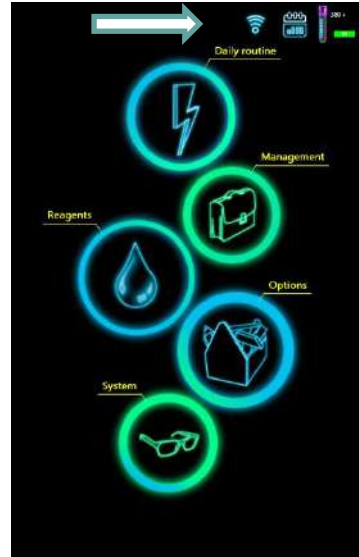

When wired network is available, a network plug icon is displayed.

Tapping on this icon brings up the list of available wireless networks.

Tap on a network to access its details.

Tapping on the X in the row of a network will remove it from the list of networks.



Wi-Fi settings

Network connectivity supports the following encryption protocols:

- open
- shared
- WPA2 Personal
- WPA Personal

DHCP is always assumed for Wi-Fi.

If required, you can enter the password for the network, and then tap “Join” to start connecting.

For details on the network, please contact the local network administrator.



Wired network settings

Access settings by tapping the network plug icon in the top of the screen.

Actual settings are displayed in the lower half of the screen. Enter your settings in the upper half of the screen.

If DHCP is enabled, you do not need to specify network related data.

If DHCP is not supported, please contact your network administrator for settings.

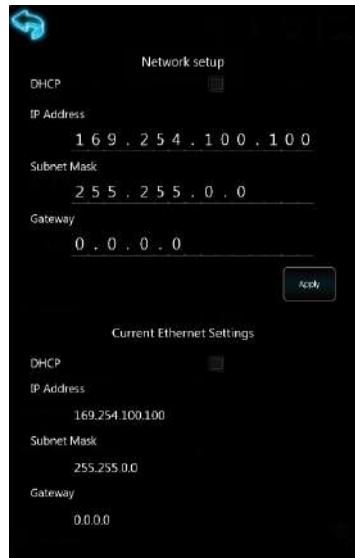

Daily operation

Your daily routine will mostly consist of powering on the analyzer, running samples with unique sample ID's and creating reports.

It is good laboratory practice to run QC material on a daily basis to ensure and allow controlling the performance of the analyzer on a day-to-day basis.

You will most probably create reports of the samples run and occasionally you will need to find earlier results of individual patients.

All these tasks are outlined below to give you an easy to follow guide and make laboratory work routine and fun to do.



Power on

Hemolyzer 3 NG will mostly be waiting in stand-by mode.

Push the START button to wake up the analyzer, the status ring on the top will change color.

The user interface will be displayed shortly, and the analyzer is ready for work.

The fluidic system will always require initialization, a programmed startup. This is indicated by a yellow analyzer in measurement mode.

Tap the yellow icon to start the initialization.





Running samples

To start measurements, tap *“Daily routine”* and then tap *„Sampling”*.

It is recommended to verify the accuracy of measured parameters. The practical method is running a QC measurement using control material.

Closed tube mode

	<p>The opening on top of Hemolyzer 3 NG for Closed vials is designed to receive blood collection tubes of defined dimensions with caps on.</p>
	<p>To avoid personal injury, do not put your finger into the opening. Avoid placing objects different from a blood collection vial to avoid damage to the analyzer.</p>
	<p>Avoid putting tubes without caps into the sampling mechanics.</p>

To run samples, you need to enter the *“Daily routine”* menu.





Enter the sample ID to the input field using the on-screen keyboard or an external keyboard.

Select a profile by tapping the Profile list and place the closed sample vial into the sample opening on the top of the analyzer.



	<p>For best results, always choose the profile that best fits the sample type.</p> <p>Use Control profile when running control blood samples.</p>
---	---

Failure to use Control profile for control blood samples may result in wrong WBC differential results.

	Avoid putting more than one barcode label onto the blood collection tube to avoid the tube getting stuck in the sampling mechanics.
	Hemolyzer 3 NG's sampling mechanics is equipped with a cap detector. Cap detector operation may be impaired by additional labels put on the sample vial, and Hemolyzer 3 NG may refuse to run such tubes.

Tapping the analyzer symbol in the center will start the measurement.

Hemolyzer 3 NG will lower the sample vial into the sampling mechanics and will take a sample with its built-in cap piercing needle.



When the sample has been taken, the vial will be returned to the Operator.

Results will be available in a minute.

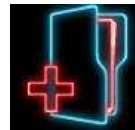
A new result will be indicated by a small icon in the lower right corner of the screen. Tapping this icon will take you to the Results screen and data will be displayed on the screen.



Open tube mode

	To run samples in Open tube mode, the blood collection tube must not have its cap on.
	Always follow laboratory practice by wearing necessary protective gear to avoid getting in contact with blood samples, which must be treated as potentially biohazard material.

To run samples, you need to enter the “Daily routine” menu.



Enter the sample ID to the input field using the on-screen keyboard or the external keyboard. Select a profile by tapping the Profile list.

Tap the “open mode” button.

Hemolyzer 3 NG will present the open sampling tip above the START button.

Hemolyzer 3 NG is ready to run the sample in open mode.

Guide the open vial so that the sampling tip is immersed in the sample.

You can start the measurement by tapping the color “Press To START” icon on the screen.

Tapping the color symbol on the screen will start the measurement, and Hemolyzer 3 NG will take the necessary amount of sample from the vial.

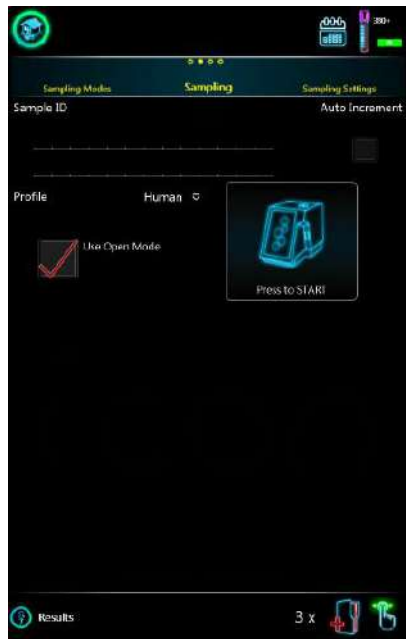

After sampling is done, the analyzer will give a tone and the mechanical start button will lit up in red color and the tip will be retracted and washed. You can now take the sample vial away. Results will be available after a minute.



During sampling, always pay attention to hold the vial parallel to the flexible tip.

Never force the tip to bend in order to avoid accidental contact with sample upon retraction of the flexible tip.

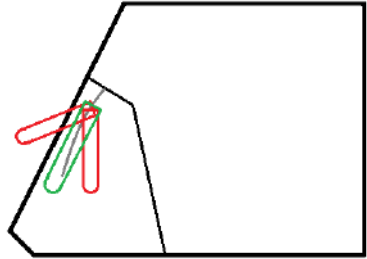

A new result will be indicated by a small icon in the lower right corner of the screen. Tapping this icon will take you to the Results screen and data will be displayed on the screen.



Results

Hemolyzer 3 NG can display results in two ways:

- in short form during measurement in the lower half of the screen;
- a full (detailed) view is accessible in “Results” (database)

Short (Quick) result

The results appear in the lower half of the screen. Only 10 parameters are displayed. You can tap the values for details, and you can tap the histograms for a zoomed view.

If flags are displayed, tap on the values to see flag messages.



Full result (Full screen)

Full, detailed results are available from the Main menu under “Daily routine”/ Results.

Flags are displayed written in yellow color.

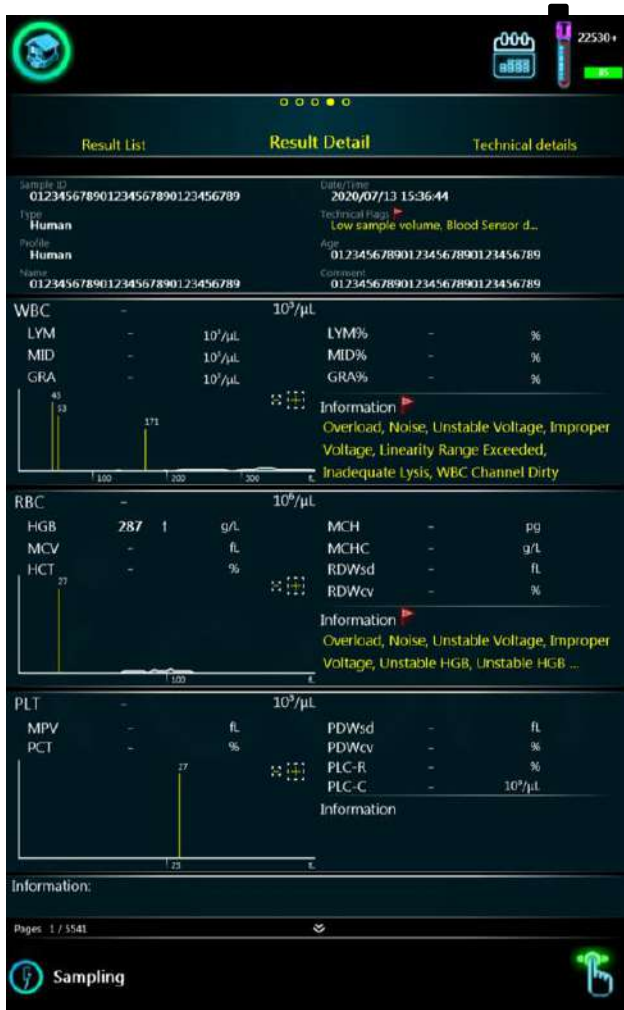

Flags

The screen below intentionally contains an error flag (red flag).

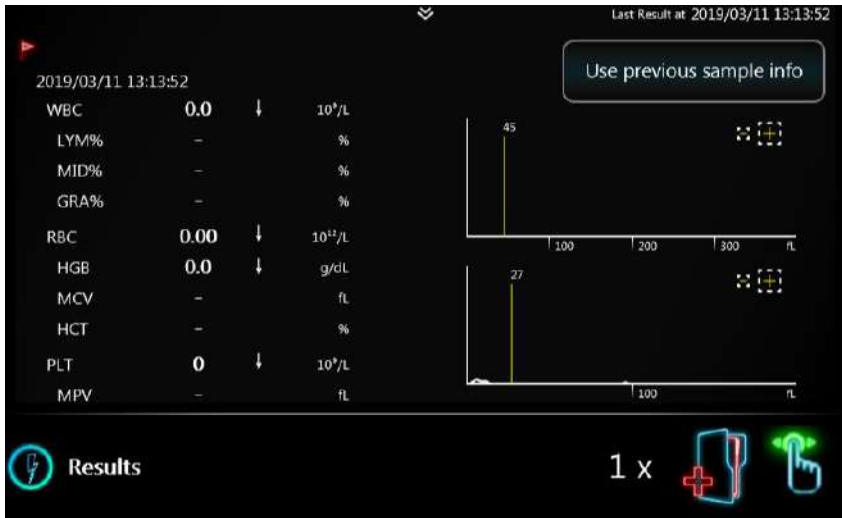

Technical flags

Hemolyzer 3 NG is able to display technical warning flags. Flags can appear in various locations, depending on significance and relevance. Flags by the Sample ID refer to sampling or sample handling mistakes. Flags displayed in WBC and RBC groups refer to parameter related irregularities. Technical flags rather give guidance for the user, an indication of not operating the analyzer as recommended.

Flags have different levels of significance. Each flag has two confidence levels. As long as results are not negatively influenced by the detected conditions, results will be displayed along with the flags. As soon as severity of the problem goes beyond safe result interpretation, and would impact readings, values will be dashed out.

List of Technical Flags

Improper Voltage	
Meaning	Your analyzer might be operating outside the described environmental conditions.
Type	RBC, WBC
Effect on result	Results are NOT displayed.
Resolution	Please observe environmental requirements. Maybe cleaning is due.

Inadequate Lysis	
Meaning	The sample could not react to the chemicals in the lysing reagent.
Type	WBC
Effect on result	WBC, Diff# and Diff% values are marked with *
Resolution	Check Lyse in external tubes. Rerun the sample.

Noise	
Meaning	Only original reagents should be used with Hemolyzer 3 NG.
Type	WBC, RBC
Effect on result	Results are NOT displayed.
Resolution	Verify reagents.

Low sample volume	
Meaning	There was an inadequate quantity of sample in the sampling vial.
Type	Technical
Effect on result	Results are displayed.
Resolution	Rerun the sample if possible. Please observe minimum sample volume guidelines.

Overload	
Meaning	Inadequate volume of reagents, or reagents improperly connected.
Type	RBC, WBC
Effect on result	Results are NOT displayed.
Resolution	Verify right connection.

Linearity Range Exceeded	
Meaning	The results are beyond the linearity range of the analyzer.
Type	RBC, WBC
Effect on result	Results are displayed.
Resolution	Run the sample after 1:1 predilution.

Unstable HGB	
Meaning	Improper homogenization of sample.
Type	HGB
Effect on result	Results are NOT displayed.
Resolution	Rerun the sample. If maintenance related cleaning actions have been omitted, please do them now.

Unstable HGB Baseline	
Meaning	HGB detection was unreliable.
Type	HGB
Effect on result	Results are NOT displayed.
Resolution	If maintenance related cleaning actions have been omitted, please do them now.

Unstable Voltage	
Meaning	Inadequate sample kinked external tubes resulted in insufficient volume of reagents aspirated.
Type	WBC
Effect on result	If the significance of the problem is LOW : WBC, Diff# and Diff% values are marked with * If the significance of the problem is HIGH : Results are NOT displayed.
Resolution	Please verify external reagent connections and rerun the sample.

Unstable Voltage	
Meaning	Inadequate sample kinked external tubes resulted in insufficient volume of reagents aspirated.
Type	RBC
Effect on result	If the significance of the problem is LOW : RBC, PLT and related values are marked with * If the significance of the problem is HIGH : Results are NOT displayed.
Resolution	Please verify external reagent connections and rerun the sample.

WBC Channel Dirty	
Meaning	Cleaning was omitted recently.
Type	WBC
Effect on result	WBC, Diff# and Diff% values are marked with *
Resolution	Please clean the analyzer (“Open Cleaning”) and run a “Rinse” process

WBC Fallback	
Meaning	Inhomogeneous WBC concentration but evaluation has succeeded.
Type	Technical
Effect on result	Results are displayed only on technical view.
Resolution	Rerun sample. Can be sample related.

3part Fallback	
Meaning	Inhomogeneous WBC concentration but evaluation has succeeded.
Type	Technical
Effect on result	Results are displayed only on technical view.
Resolution	Rerun sample. Can be sample related.

Diff fallback	
Meaning	MID population is over 50% due to possible wrong distribution of high GRA population.
Type	WBC
Effect on result	WBC, Diff# and Diff% values are marked with *
Resolution	Rerun sample. Can be sample related.

Blood Sensor Disabled	
Meaning	Open sampling blood sensor turned off by user.
Type	Technical
Effect on result	Results are displayed.
Resolution	N/A

Interpretative Flags

This flagging function will display text if a given parameter is outside the normal range. These flags will appear in the information box below the results.

Parameter	Low flag	High flag
WBC	Leukopenia	Leukocytosis
LYM	Lymphopenia	Lymphocytosis
GRA	Granulocytopenia	Granulocytosis
RBC	Anemia	Polycythemia
MCV	Microcytosis	Macrocytosis
MCHC	Hypochromia	Hyperchromia
RDW sd		Anisocytosis
PLT	Thrombocytopenia	Thrombocytosis
MPV	Microcytic PLT	Macrocytic PLT

Reports

PDF

Hemolyzer 3 NG is able to send reports ready to be printed via email or is able to save reports to USB Hard Disk, stick, etc.

Reports include all entered patient data, along with reported parameters, histograms and additional notes, comments created using the analyzer during or after analysis.

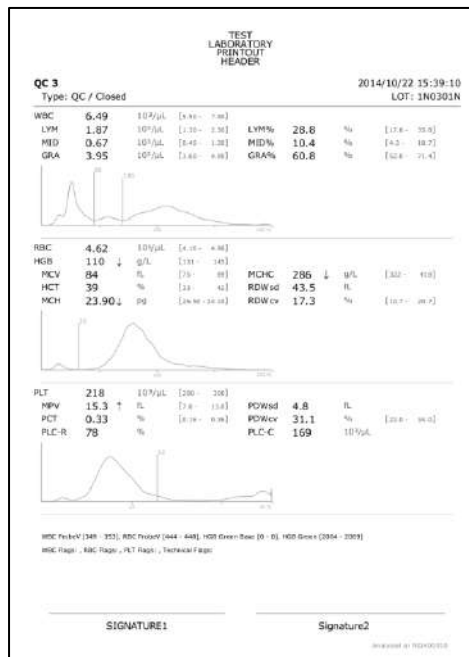

Note: if you choose to export one single result into one PDF file, then the SampleID (if defined) will be added to the name of the PDF file. PDF export file name is generated as follows: SampleID_DATE_TIME.PDF

Printer Thermal

Hemolyzer 3 NG is able to send report to connected thermal printer. When Hemolyzer 3 NG detects Thermal printer is connected proper symbol will be shown on status bar.



A printer report looks as shown on the image to the right.

It is possible to hide histograms from the printout. For details, see Settings / Printout.

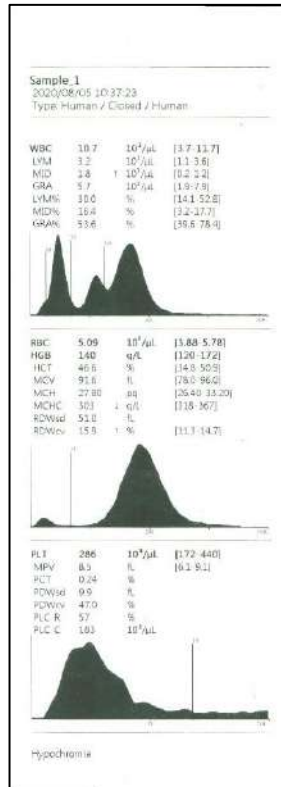

Printer PCL5/6

Hemolyzer 3 NG is able to send report to connected printer which is capable to interpret PCL5/PCL6 printer language. When Hemolyzer 3 NG detects PCL5/PCL6 compatible printer is connected proper symbol will be shown on status bar.



A printer report looks as shown on the image to the right.

It is possible to hide histograms from the printout. For details, see Settings / Printout.

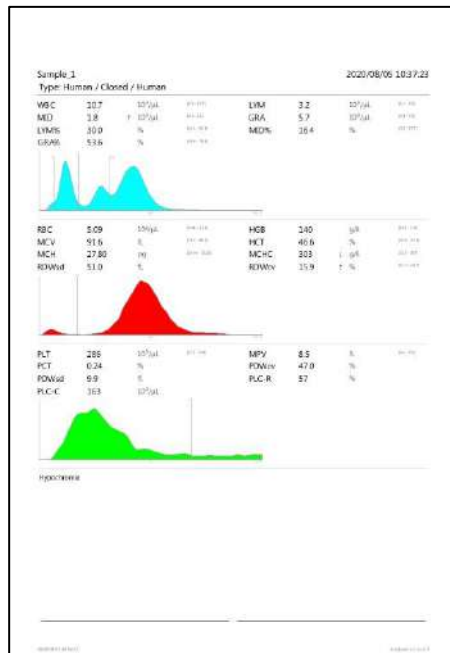

Note: Hemolyzer 3 NG supports a limited set of printer languages. The printer must support one of the following languages:

- PLC5
- PCL6
- ESC/POS

Printers not supporting the above printer languages will trigger a printer symbol with a question mark on the screen, and will print scrambled reports, or a lot of empty pages.

Hemolyzer 3 NG can force the ESC/POS language for unknown printers.

Power off

A regular power off can be initiated at any time. Processes that actually run the fluidic system cannot be interrupted.

To power off, press and hold any point of the screen for 3 seconds. A quick menu will be displayed offering various actions including shutdown (power off).

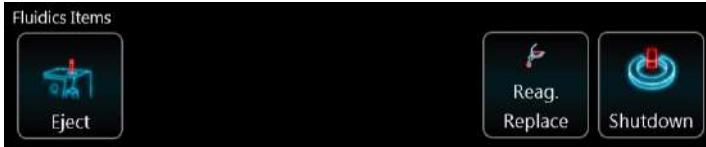

Shutdown will prepare the system for a longer period of inactivity. The process takes about a minute, after which the system will automatically power off, leaving Hemolyzer 3 NG ready to be disconnected from the mains if necessary.

To clean the piercing needle during Shutdown process run the specialized Shutdown with Needle Clean process from Management menu. See Shutdown options below:

1. Shutdown (Location: Management/Maintenance/General Menu)

The analyzer will perform the regular shutdown procedure by washing the Sampling Tip, priming a small amount of Diluent and rinsing the Shear Valve.



Or in submenu:

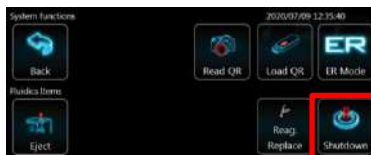

2. Shutdown with Needle Clean (Location: Management/Maintenance/General)

The analyzer will perform the regular shutdown procedure with the additional needle cleaning. An empty control blood vial with 2-3 ml of H3/5-Hypoclean (hypochlorite solution) must be prepared in advance.



ER mode

Hemolyzer 3 NG is able to run in ER (“Emergency Room”) mode. In ER mode user has limited access to user functions.

The user can access Sampling, Results and Maintenance functions. This mode allows operating the analyzer in an environment where users do not deal with analyzer setup on a daily basis. Settings are however accessible with a password.

ER Sampling

Same operations are available like in the “Daily routine” menu “Sampling” submenu with restrictions:

- mandatory Sample ID function could be activated by service personnel
- Auto-increment option could be disabled by service personnel
- Open mode option could be disabled by service personnel
- calibration cannot be accessed



Additional feature is automatic QC mode detection. If existing QC LOT identifier is entered into SampleID field, Hemolyzer 3 NG will mark the upcoming measurement as QC measurement.

ER mode behavior can be set up in Service Menu. For details, see next pages.

ER Results

Same operations are available like in the “Daily routine” menu “Results” submenu with restrictions:

- calibration results are unreachable

Possible options in ER mode (Service Setting required)

- Forced Sample ID, Operator ID
- Pre-mixing of sample in closed mode
- Disable Profile selection (Human limits will be used)
- Hide “Reuse previous sample data” button
- Hide 3-part results
- Automatic Rinse, FastBlank
- Adjustable FastBlank limits for WBC, RBC and PLT values
- Sampling menu is automatically displayed after 5 minutes of inactivity
- Hide auto-increment option
- Hide open mode



Switching between ER and Admin mode

User can change between ER and Admin mode by accessing local menu (tap-hold screen).

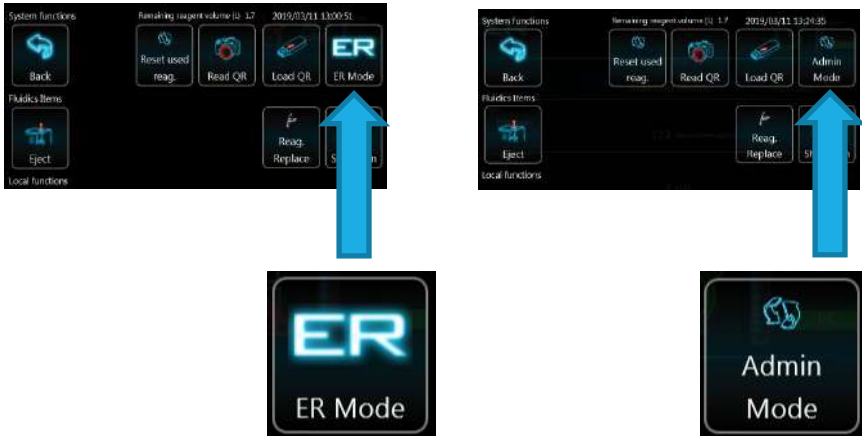

Switching from ER mode to Admin mode requires a password.

The password is a series of 6 (six) "Tap" gestures.



Calibration

Hemolyzer 3 NG as any laboratory analyzer can be calibrated. For this purpose, Hemolyzer 3 NG offers two ways to perform this task. Hemolyzer 3 NG arrives to your laboratory factory calibrated.

Calibration is necessary if laboratory standards require it, or when maintenance actions require you to do so. You may need to calibrate upon installing new reagents.

Target values

Calibration is performed comparing the reported values of the analyzer to a known specimen, or standard. Hematology analyzers have their own calibrator materials called Hematology Calibrators.

A calibrator material is made by using human samples mixed with specially treated particles to guarantee stable values for parameters over the stability period of the calibrator material. All calibrator products come with a list of the target values of calibrated parameters.

It is recommended to use calibrator material called H3/5-Cal.

These target values represent the standard to which your analyzer's reported values are compared.

Mode-to-mode calibration

Calibrating Open Sampling Mode to Closed Sampling Mode



This analyzer has **two separate** sampling modes and each mode has its own set of calibration factors. These modes can and have to be calibrated separately.

To make sure that the analyzer reports identical values for open and closed mode sampling of the same sample, the following method is recommended:

1. Make sure that the analyzer has been calibrated in closed mode using calibrator material.
2. Run a live (human) sample in closed mode 3 times.
3. Go to Results, and calculate the mean values of WBC, RBC, HGB, MCV, RDWcv, PLT and MPV for the 3 repeated measurements.
4. Note (write down) these mean values.
5. Start an open mode calibration.
6. Enter the values that you wrote down previously as target values.
7. Run the same live (human) sample in open mode 3 times.
8. Accept the calibration.
9. The two sampling modes have been successfully calibrated to one another, thus the analyzer will be able to report matching results for human samples.

Note: Step 3 – 6 can be substituted by using “Calibrate” function on selected measurements via accessing local menu (tap – hold screen).



Automatic calibration

Hemolyzer 3 NG offers an automatic calibration method to keep the process as simple as possible.

The steps of automated calibration are as follows:

- enter target values
- run the calibrator material a specified number of times
- accept the calibration result

Hemolyzer 3 NG can calibrate the below measured parameters:

- WBC, RBC and PLT count
- HGB, MPV, RDW and MCV value

Check the box in front of parameters you want to calibrate.

Enter target values either by defining the expected values of the calibrator found on the accompanying insert or, scan the special barcode containing all these data using Hemolyzer 3 NG's built-in camera.



Select measurement mode (open or closed tube sampling), insert the vial with the calibrator material into Hemolyzer 3 NG’s sample opening or immerse the flexible sampling tip into the sample and press START.

Hemolyzer 3 NG will mix and run the sample and will calculate the mean values of the measured parameters. The mean value will be used to calculate the calibration factors using the formula below

$$CAL_{parameter(new)} = \frac{Parameter_{target}}{Parameter_{mean}} * CAL_{parameter(old)}$$

Each sample run will be listed on the screen, with each parameter to be calibrated.

Consequent measurements (samples) will be displayed on small Levey-Jennings charts, each sample represented by a small dot. This screen allows a quick overview of the process, displaying calculated Mean and CV values.

Highlighted samples can be deleted (“Drop”) from the list of measurements.

Red highlight indicates that accepting these values would push the calibration factor to its 30% limit. Red highlight is intentional to demonstrate error.

“Reset” will clear values and cancel the calibration process.



Manual calibration

Hemolyzer 3 NG also offers the option to enter calibration factors manually. Possible values are 0.70 - 1.30.

This way the operator can modify calibration factors parameters individually.

Manual calibration can be a much faster method than the built-in automatic calibration service, but care must be taken when changing parameters manually.

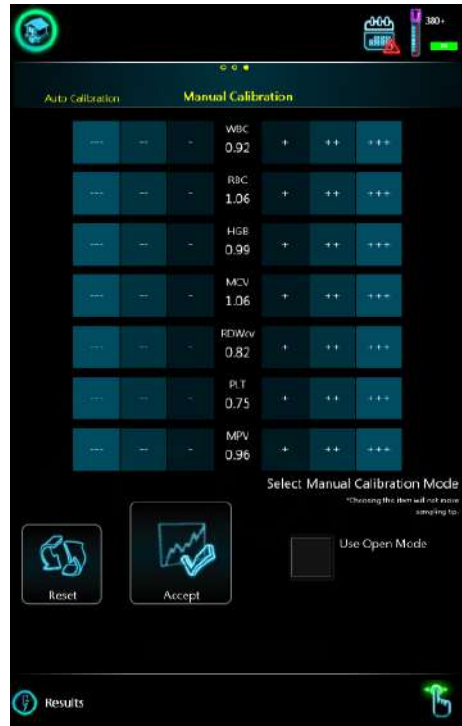

It is recommended to verify the effects of the manual calibration by running specimens with known values of measured parameters.

Each calibration factor can range from 0.70 to 1.30 allowing a $\pm 30\%$ range for adjustment.

QC – Quality Control

Hemolyzer 3 NG, just like any laboratory analyzer needs verification of its performance from time to time. For this purpose, Hemolyzer 3 NG offers the Quality Control service.

Quality Control is a built-in tool offering an easy method to track the performance of Hemolyzer 3 NG. Enabling QC measurement warning allows the system to pop up a message about QC measurement importance after every daily startup.

Expected values

Quality Control is performed measuring the same specimen over a period of time. Hematology analyzers have their own control material called Control Blood.

Control blood is made by using human samples mixed with specially treated particles to guarantee stable values for parameters over the stability period of the control material. All control blood products come with a list of the expected values of parameters.



Please always observe the package insert of the control material; such products require storage in a refrigerator. Prior to using the control material, it must reach optimal (room) temperature. Always follow the instructions accompanying the control product.

These expected values represent the standard to which your analyzer's reported values are compared. It is recommended to use control material H3-Check, developed specifically for Hemolyzer 3 NG.

Recommendation to perform Quality Control measurements after turning on the analyzer – a hint message is displayed on the measurement screen after the first entry each day, to remind users to verify the analyzer's performance by running QC measurement with H3-Check control blood.



QC measurement warning

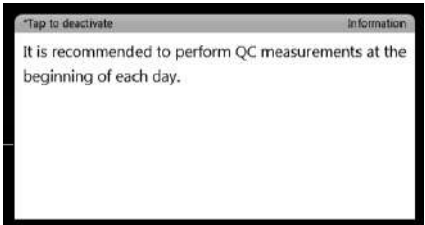

Tap to deactivate Information
It is recommended to perform QC measurements at the beginning of each day.

This function can be switched on and off. (Location: Options/Customization)

Assay sheets

Hemolyzer 3 NG offers entering QC Assay values via QC codes using the onboard camera. Analyticon provides Assay Sheet values in QR code form as well. To read the QR code, you will have to print it then present it to the analyzer as described below:

- To activate QR code reading sequence, tap and hold any point on the screen.
- Tap the small camera icon.

The screen will change, and you will see a live image of what the camera “sees”. The camera is located in the center of the letter “o” in the “Icon” text at the top right corner of the display.

Hold the printed sheet in front of the analyzer, making sure that the sheet is not curved or bent. The QR code should be located in the center of the live image. The camera has a fixed focus find the best distance to read the QR.

Hemolyzer 3 NG will acknowledge the Assay Sheet with an audible tone. The data will be entered in the QC mode available for measurement.

Make sure to show one QR code at once, so that the SW can read data properly.

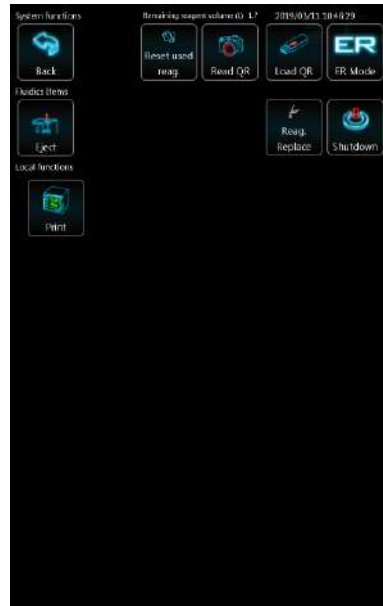

Assay sheet data can also be entered manually.

The list of QC materials can be seen with a manual entry point in the top row.

Banks can be selected as targets for measurement by ticking the box in front of the specific row.

Banks can be deleted by ticking the box in front of the specific row and going to the local menu and selecting “DROP”.

Tapping the first (top) row will enter the screen where manual definition of parameters is possible.



With manual entry you can define expected values and tolerances along with LOT ID and expiration date.

Your changes will only be saved if you tap the “ACCEPT” icon. You can cancel data entry by tapping the “RESET” icon and discarding changes by tapping the HOME icon in the top of the screen.

QC materials (banks) once saved, cannot be edited. If you made a mistake and corrections must be made, please delete the actual QC bank and enter a new bank.



QC diagrams

Hemolyzer 3 NG can represent QC data in two views. QC data are only shown if there are actual QC measurements stored in the analyzer's memory.

One view lists data in a graph where values of parameters are displayed against measurements in sequence (time).

You can initiate a measurement by tapping the analyzer icon on the screen.

New QC measurements will be displayed on the chart.

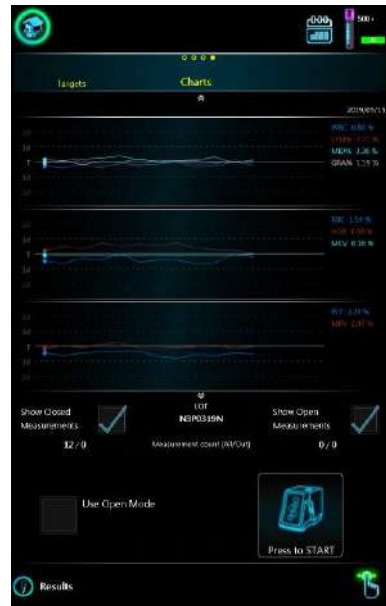

The second view displays records and the respective parameter values on a circular diagram. (Access it by sliding up the screen)

You can initiate a measurement by tapping the analyzer icon on the screen.

New QC measurements will be displayed on the chart.

Note: The number of displayed parameter depends on QC Parameter setting (Short/All).

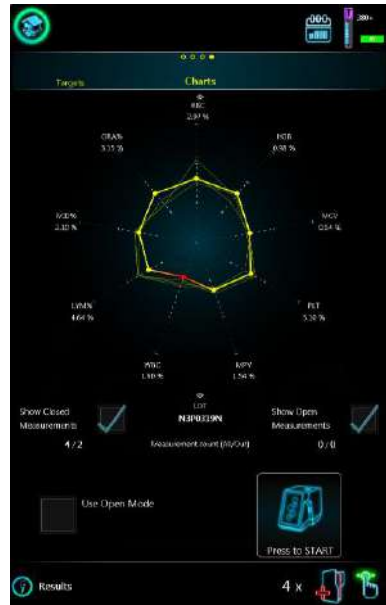

QC reports

Hemolyzer 3 NG can print Levey-Jennings diagram via thermal and PCL5/6 printer as well. To print diagram tap “Print” button via accessing local menu (tap – hold screen).

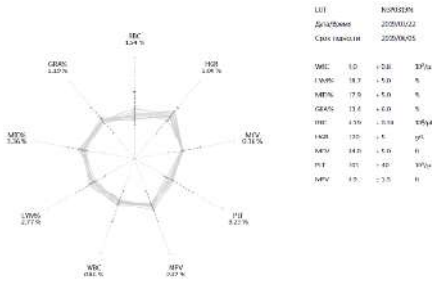
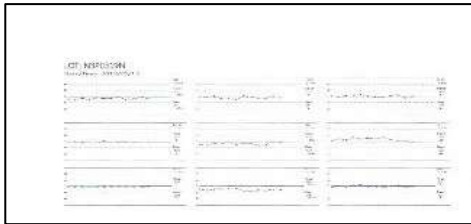

LOT	N3P0319N	
DATE/Time	2019/05/15	
CRIP PARAMETER	2019/05/15	
WMC	0.0 ± 0.8	SP/ul
LWPC	18.7 ± 5.0	%
MPC%	17.0 ± 5.0	%
GCW%	17.0 ± 5.0	%
WPC	1.00 ± 0.10	mg/dl
WCR	100 ± 4	g/L
MFR	14.0 ± 1.0	H
PIF	101 ± 40	W/ul
MPCV	0.5 ± 0.5	H



BLV	R049220	
DATE/Time	2019/05/15	
CRIP PARAMETER	2019/05/15	
WMC	0.0 ± 0.8	SP/ul
LWPC	18.7 ± 5.0	%
MPC%	17.0 ± 5.0	%
GCW%	17.0 ± 5.0	%
WPC	1.00 ± 0.10	mg/dl
WCR	100 ± 4	g/L
MFR	14.0 ± 1.0	H
PIF	101 ± 40	W/ul
MPCV	0.5 ± 0.5	H

WMC (0.0 SP/ul) | LWPC (18.7%) | MPC% (17.0%) | GCW% (17.0%)

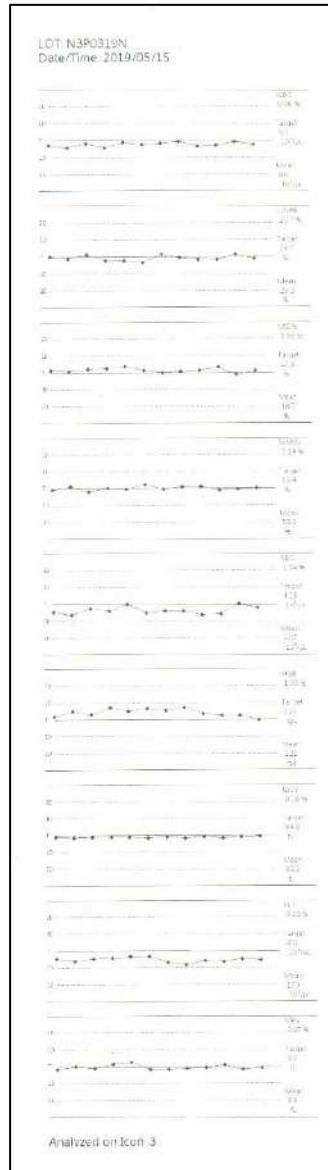

Database functions

Browsing records

The database allows browsing records listed in rows. Swiping (scrolling) gestures can be used to access various views of the database.

The database is arranged into three separate sets of data:

- Samples, QC measurements and Calibration data, Fast Blanks, Recycle Bin
- Within each set, you can browse by date
- Swiping LEFT will reveal more and more detailed data of the row, record examined

Results	Human	↑	↑	↑
		Date	Record	Details
		↓	↓	↓
	QC	↑	↑	↑
		Date	Record	Details
↓		↓	↓	
Calibration	↑	↑	↑	
	Date	Record	Details	
	↓	↓	↓	
Fast Blank	↑	↑	↑	
	Date	Record	Details	
	↓	↓	↓	
Recycle Bin	↑	↑	↑	
	Date	Record	Details	
	↓	↓	↓	

Swiping the screen in the left or right direction will switch pages displayed.

Swiping the screen up or down will scroll the view up or down: you can scroll between dates, groups of records and individual records.

All deleted records are moved to the Recycle Bin. Records in the Bin can be restored.

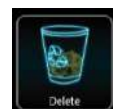
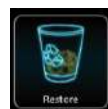

Database context menu

Tapping and holding any point of the screen in database view brings up a so-called context menu screen.

The screen has operation related functions in the top. The central region has icons representing functions related to actions corresponding to database records.



Selecting records

By tapping “Same Day” you can select records measured on the day of the actual result.

By tapping “Same SID” you can select records matching same SampleID of the actual result.

Tapping “Selection Start” will allow multi-selection of results. You will be taken back to the database table view. You can select the END of the selection by ticking the box in front of any sample. All samples between the “first” (where selection started) and the “last” (the one you ticked) will be selected.

Select All – the feature is available if at least one record was selected.

The number of selected records will be shown under the list of records. By (un)tickng the box by the “3” of 3668 will deselect ALL records.

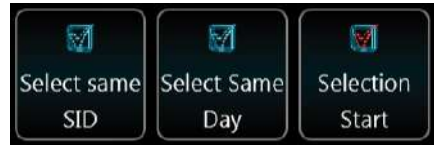

Moving to specific date in database

After selecting date with date picker tap “Jump” button to move the corresponding results in database list. Hemolyzer 3 NG will execute the jump operation only if database contains records with the selected date.



Selecting records between two dates

Follow the process below to select all records between two dates:

1. Tap local menu
2. Enter start date
3. Tap “Jump”
4. Select first record
5. Tap local menu
6. Tap “Selection start” - Checkbox of first record turns red
7. Tap local menu
8. Enter end date
9. Tap “Jump”
10. Select last record – All records between start and end dates will be selected

Search (filtered view)

You can search for any string contained in Sample ID and in Comment1-3 fields.

You can start the search only from the **database category view**.

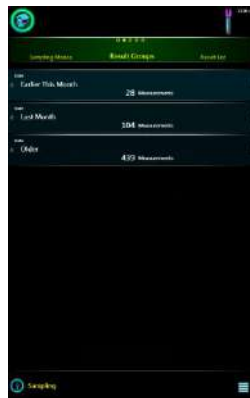
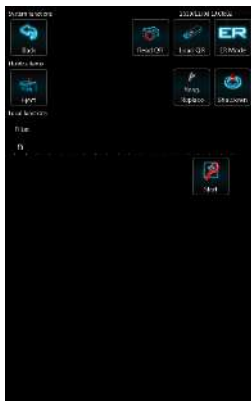

Tap the menu symbol, enter your search criteria. Enter minimum 2 characters. Search function works on normal measurement results, including those in the Recycle Bin.

Matching results will be displayed in a separate database view.

Managing data

Tap the corresponding icon to activate the function:



- print results via connected thermal or PCL5/6 printer
- export results in TSF format to USB HD (Tab Separated File – ideal for external processing)
- e-mail results in PDF format
- save reports in PDF format to USB HD
- save reports in raw data format to USB HD
- send results to LIS
- drop selected records into Recycle Bin
- CV% calculates CV data of selected results.

Managing data in Recycle Bin

Tap the corresponding icon to activate the function:

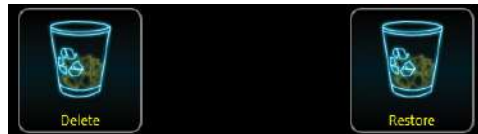

- permanent delete selected records
- restore selected records

Sending e-mail

To email, enter the address of the recipient. Email settings are available under Options menu Functionality submenu.

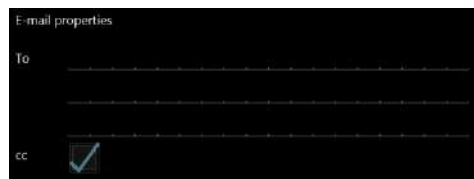

Keeping “CC” checkbox selected will send a copy to the default email address (as defined under email settings).

LIS transmission error

If the analyzer software was unable to send results to the configured HL7 server (network error, server error), there will be an “unsent messages” icon displayed at the top of the screen. The number on the icon will represent the number of unsent messages. Unsent messages will be entered in a queue.



Tapping on this symbol will display a context menu.

The user can decide to resend all unsent messages anytime. (“Send”)

The user can also decide to empty the unsent results queue. (“Cancel all”)



The attempt to reestablish communication link and resend unsent messages depends on relevant setting. This could be 1 / 4 / 24 hours or never. If the setting is never the software will never resend unsent messages, but the user should clear the queue.

Maintenance

Cleaning the analyzer

The outer cover of Hemolyzer 3 NG is made of plastic, and polycarbonate. The back plate is made of stainless steel.

The external plastic parts can be cleaned with lint free cloths soaked in light soapy water, or alcohol-based cleaning materials, typically alcohol-based window, or computer display cleaning solutions.

Cleaning the stainless-steel back plate should be done using alcohol-based cleaning materials, typically alcohol-based window, or computer display cleaning solutions.



WARNING

Never make the system aspirate liquids with alcohol content. Alcohol will damage internal plastic components.

Daily maintenance

- Clean outer surface
- Check reagent connector

Note: The analyzer will automatically force a sampling tip wash process to avoid the flexible tip getting jammed in the open wash head due to low usage frequency of the open sampling tip. This event is triggered every 48hrs. The counter restarts with every open sampling tip operation. (e.g. if the user runs open samples every day, the system will not clean the tip; if the user does not run open samples, then the system will wash the tip every 48hrs.)

Weekly maintenance

- Open tube sampling tip: clean the bottom of the washing head with a cotton swab
- See also at section [Cleaning procedures of the fluidic system](#) below

Emergency procedures

- Cleaning
- Power off

Reagent pack replacement

- When a reagent pack is empty (because reagent credit ran out) then a new pack must be installed.
- The process is supported by a wizard guiding you through the process.
- To access the wizard, tap the local menu button or the sample vial symbol on the screen and tap on the reagent replacement icon.
- Follow the instructions on the screen:



- Open new pack, locate IFU with QR code
- Remove caps, open vial seals
- Move reagent tubes from old pack to new pack (make sure codes match, do not touch liquid)
- Empty waste and tap the icon below to reset waste counter



- Scan QR code
- Initiate auto-prime



Replacing reagent bottles

- In case of using bulk reagents, and one of the reagent containers becomes empty, scan the QR code of a new bottle and connect the bottle to the analyzer.

Cleaning procedures of the fluidic system

The Software will regularly ask for cleaning based on its built-in timers. You will be asked from time to time to do the following:

- Running vial filled with cleaning solution *
- Aspiration of cleaning solution through sampling tip *
- Performing a “Rinsing” action to clean apertures *
- RBC cleaning – targets RBC aperture and related tube sections *
- SV Rinse – allows flushing the ceramic valve to ensure reliable operation (this function is included in standard operation invisible to the User, yet this process is necessary to avoid problems).

Frequent “Noise”, “Overload” and “WBC channel dirty” problems can be reduced or eliminated by running “Open cleaning” and “Rinsing” functions.

*= these functions have frequency based on sample count or days elapsed. The counters can be set by Service.

A practical sequence of cleaning is as follows:

Closed Cleaning – Open Cleaning – RBC Cleaning – Rinsing

You can follow the above cleaning procedures even on a daily basis.

Some cleaning processes will ask for cleaning solution. Use Analyticon H3/5-Hypoclean solution to keep the analyzer on its best performance.

Software update

You can initiate loading the analyzer with a SW upgrade by tapping the proper button in System menu / About submenu. Contact your Service team for details.

Management menu

Maintenance

Maintenance menu allows running processes related to maintaining reliable operation:

- Priming, draining reagents
- Cleaning procedures
- Diagnostic functions
- Other functions

Prime & Drain

Swiping left on the Prime line of Maintenance opens the Prime menu, where the user can instruct the analyzer to aspirate, prime reagents individually if necessary.

Drain All will drain the system without the need to disconnect reagents.

Drain Full will drain the system and reagents must be disconnected.

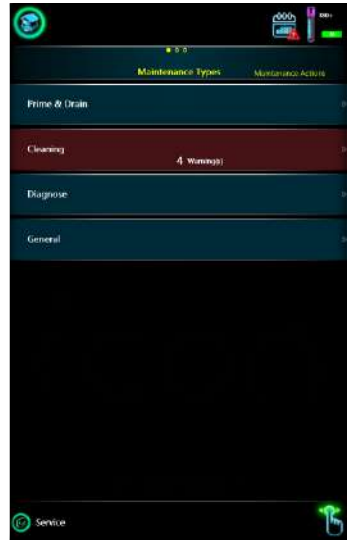

Cleaning

It is possible to run various cleaning actions that help keeping the system in good working conditions.

You can clean the closed and open sampling paths, and you can initiate a rinsing action which is designed to flush and prime liquids in the measuring system.

It is also possible to run RBC cleaning and SV Rinse.

We recommend running RBC clean after performing Open cleaning.



Other

These functions are used when the analyzer is to be out of operation for a longer period of time.

Preparing for shipment supports draining and cleaning all tubing paths inside so that the analyzer can be transported or stored for a longer time.

Shutdown will just turn the unit off after a thorough preparation of the system for unpowered state.

Shutdown with Needle Clean: the analyzer, while running, will eventually collect some spilled blood from sample vials. This blood does not interfere with results, does not cause cross-contamination of results, but it may cause faults in the needle cleaning procedure. Dried blood may obstruct operation of the needle cleaning mechanism. The needle is not accessible to the operator.

To avoid such problems, it is strongly recommended to use a needle cleaning vial at the end of the daily routine.

Fill an empty black cap cleaning vial or control blood vial with 2-3ml of H3/H5-Hypoclean and close the vial. Standard sample vials may not reach the areas of the needle that need cleaning.

When you are ready to shut down the analyzer at the end of the day, insert the vial to the sample opening and start the Shutdown with Needle Clean process.

The analyzer will use the vial to clean and rub the needle. The vial is left over the needle for 20 seconds so that the cleaning liquid inside will dissolve eventually dried blood. At the end of the process the cleaning vial will be returned to its top position and will be ready to be removed.



Alarm Clock symbol

When automatic maintenance and management functions are enabled in Service Menu, Hemolyzer 3 NG will display a green alarm clock symbol in the top of the screen.

Tapping on this symbol will display a screen which displays scheduled events.



System functions

2020/08/05 10:18:04

Back Read QR Load QR Admin Mode

Fluidics Items

Eject Reag. Replace Shutdown

Local functions

Last	Schedule list	Next
2020/08/05 09:48:21	Auto-FastBlank	Not Available
2020/08/05	Closed Cleaning	2020/08/12
2020/08/05	Open Cleaning	2020/08/12
2020/08/05	RBC Clean	2020/08/12
2020/08/05 09:42:39	Auto-Rinse	Not Available
	Remote Access	Not Available
	Send diagnostics file	2020/08/05 09:08:35

Update: 2020/08/05 10:18:01
Last operation: 2020/08/05 10:17:51

Note the times and dates when specific functions can be initiated by the analyzer.

Diagnostics

Swiping left on the Diagnostics line of Maintenance opens the Diagnostics menu, where the user can instruct the analyzer to run self-testing processes, like a Fast Blank.

Fast Blank will run an empty measurement with reduced reagent usage to verify the cleanliness of the system and of system reagents.

Fast Blank results are displayed in the lower right corner of the screen showing WBC, RBC and PLT results. HGB values are NOT checked in a Fast Blank test.

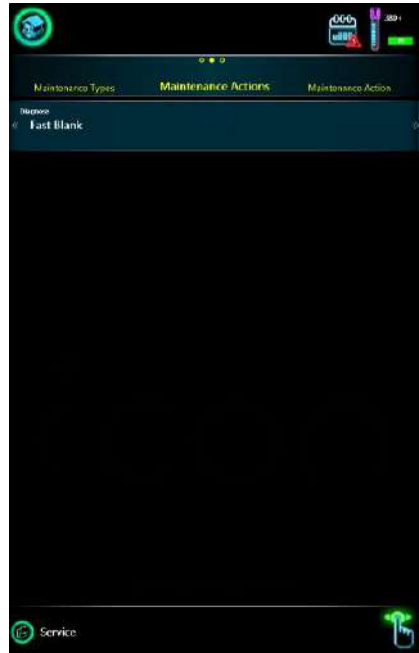

The same Fast Blank process is run during initialization of the analyzer.

Hemolyzer 3 NG will accept FastBlank values if the values are below the following thresholds:

WBC < 0.2; RBC < 0.05; PLT < 40

HGB blank is automatically performed before each measurement.

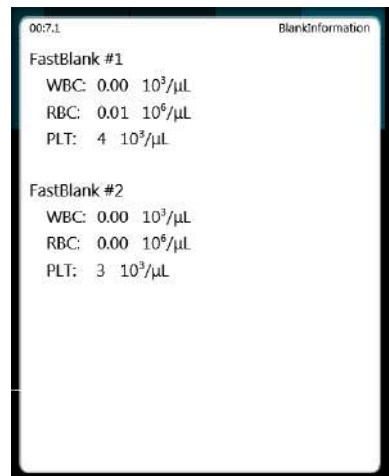

Service

This menu is password protected and it is only available for and should be used by authorized service personnel.



Supervision

History

History will list all user activity in a log, grouped into activity types. You can review Information, User action, Errors.



History details

Swiping left on a specific line of History will show the details of a specific message. You can sweep up and down to access further pages, lines.



About menu

The About screen will display instrument specific information, such as:

- Product name,
- Product ID,
- Language file version,
- SW version,
- Manufacturer name and address,
- Contact to your local service personnel (Distributor).

You can start the setting wizard.

You can initiate Remote Management (refer to your Service Personnel).



Page 2 of About displays information about the functional modules in the system.

Page 3 allows accessing Software upgrade and sending or saving diagnostic files containing information for the technical support.

Diagnostic file is often asked by the service personnel in case of any misbehavior.

This system diagnostic file can be saved to a USB pen drive or stick at this screen. It will generate *.dgst file on the USB drive. In case of a need send this file to the local support for analysis.



Database capacity

The analyzer allows managing database capacity and helps free up space as necessary. Running 50 samples a day will create about $50 \times 250 = 12500$ records over a year. The system can easily store 40.000 records, yet system speed will gradually drop as more and more records are stored.

This page offers deleting records by their age. To avoid final loss of records, you can choose to export the records selected for deleting before they are actually deleted. You can choose PDF or TSF (Text) export.

To allow exporting before deleting, you need to connect a USB storage device.

It is also possible to empty the Recycle Bin.



Status bar



Statusbar contains status symbols and shortcut to main menu. Instrument statuses are including following informations (from right to left):

1. home shortcut to return into main menu / ER mode displayed
2. alarm clock – automatic scheduling is on
3. progress symbol when fluidics action is in progress (animated)
4. printer symbol when printer is connected
 - a. 3 versions: PCL5/PCL6, ESC/POS, Unknown)
5. wireless network symbol when wireless USB dongle is connected
6. Ethernet connector symbol when wired network cable is connected
7. Available measurement count with messages:
 - a. Sample count based on actual reagent level
 - b. Expired
 - c. Inactive

D, S, L indicator, when a reagent sensor is disabled in Service menu



BS indicator, when sample movement is controlled by blood sensor

External container full symbol

Technical Specifications

Item	Description, details
Measured parameters	WBC, LYM, MID, GRA, LYM%, MID%, GRA% RBC, HGB, HCT, MCV, RDWsd/cv, MCH, MCHC, PLT, MPV, PCT, PDWsd/cv, PLC-R%, PLC-C
Measurement technology	Volumetric impedance method for WBC and RBC Photometric method for HGB at 540 nm
Histograms	WBC, RBC, PLT
Sampling mode	Closed and Open vial mode
Aspirated sample volume	Closed vial: 38 µl Open vial: 13 µl
Processed sample volume	2.5 µl
Throughput	60 tests / hour
Precision (CV%)	WBC < 3%, RBC < 2%, PLT < 5% MCV < 1%, HGB < 2%
Storage capacity	40,000 (max.) test results including histograms and patient data
User interface	LCD, 10.1", 1280 × 800 with capacitive touchscreen, portrait orientation
Languages	English, Hungarian, Italian, Spanish, German, Romanian, French, Greek, Turkish, Russian, Slovenian, Polish, Portuguese, Chinese (Simplified), Vietnamese, Bulgarian, Ukrainian, Bosnian
Connectivity	2 x USB ports, Ethernet, LIS (HL7)
Dimensions (HxWxD)	280 x 216 x 320 mm
Weight	8.7 kg
Power	External power supply, 12 VDC, 5A (100-240 VAC 50-60 Hz);
Power consumption	Maximum 45W

Reagents	Diluent, Lyse, System Solution, iHClean (optional)			
Reagent use per measurement cycle		Diluent	Lyse	SysSol
	Open mode:	5.0 ml	1.0 ml	2.0 ml
	Closed mode:	4.9 ml	1.0 ml	1.0 ml
Shipping conditions	Temperature: 2-50°C (37-122°F)			
Storage conditions	Temperature: 10-40°C (50-104°F)			
	Humidity: 20-80% relative humidity			
Operating Environment	Temperature: 15-32°C (59-90°F),			
	Humidity: 20-80% relative humidity			
Atmospheric pressure	Instrument is designed to be operated up to 2500m/8200ft above sea level (atm. press. min: 562mmHg/75kPa)			

	WARNING Only qualified service personnel may replace the internal fuse and the time keeping battery.
	When not in use or relocating, always store the analyzer in its original packaging to avoid physical damage. Storing the analyzer outside the above specified environmental conditions or outside its original packaging may impair operation and may also cause erroneous or faulty operation. Do not place the analyzer near a direct heat source or into direct sunlight. The desk supporting the instrument should be flat, horizontal and stable enough to support the weight of the analyzer and accessories.
	Operating the analyzer outside the above specified environmental conditions may impair operation and may also cause erroneous or faulty operation.

Performance Data

Precision

Precision data are listed for primary and derived parameters for n>30 below:

Parameter	CV%	Conditions
WBC	3.0	2.0 < WBC < 20.0
HGB	2.0	100 < HGB < 240
RBC	2.0	3.0 < RBC < 6.0
MCV	1.0	70 < MCV < 100
PLT	5.0	100 < PLT < 800
MPV	2.0	5 < MPV < 15

Accuracy

Data listed below are from a comparative study with Abbott Cell-Dyn 3700:

Parameter	R ² (CLOSED SAMPLING)	Conditions (whitepaper)
WBC	0.96	1.0 < WBC < 20.0
HGB	0.97	100 < HGB < 240
RBC	0.97	3.0 < RBC < 6.0
MCV	0.98	70 < MCV < 100
PLT	0.96	100 < PLT < 800
MPV	0.96	5 < MPV < 15

Linearity

Below linearity claims were measured using hematology linearity kits.

Parameter	Linearity range	Unit	Notes
WBC	0 – 100	10 ³ /μl	
HGB	0 – 250	g/l	No flagging
RBC	0 – 8.0	10 ⁶ /μl	
PLT	17 – 1000	10 ³ /μl	PLT (LoD) = 17; No flag below LoD;

Display range of parameters

Parameter	Display Limit	Unit	Notes
WBC	0-200	10 ³ /μl	
LYM	0-200	10 ³ /μl (1)	WBC>0.1
LYM%	0-100	%	WBC>0.1
MID	0-200	10 ³ /μl (1)	WBC>0.1
MID%	0-100	%	WBC>0.1
GRA	0-200	10 ³ /μl (1)	WBC>0.1
GRA%	0-100	%	WBC>0.1
HGB	0-500	g/l	
RBC	0-12	10 ⁶ /μl	
MCV	30-180	fl	RBC>0.5
PLT	0-1000	10 ³ /μl	
MPV	0-50	fl	PLT>10
HCT	0-80	%	MCV>30
RDWsd	1-100	fl	RBC>0.5
RDWcv	1-50	%	RBC>0.5
PCT	0-10	%	PLT>20
PDWsd	1-20	fl	PLT>10
PDWcv	1-100	%	PLT>10
PLCC	0-1000	10 ³ /μl	
PLCR	0-100%	%	PLT>20
MCH	0-50	pg	MCV>30
MCHC	0-500	g/l	MCV>30

Values measured below or beyond the linearity (measurement) limits listed earlier in this document will be marked with < or > symbols. E.g. PLT = 1200 will be displayed as: "PLT >1000" accompanied by a linearity range flag.

Note (1): display precision is 1 decimal digit for diff absolute counts; diff values will receive an asterisk ("*") flag if 0.1 < WBC < 1.0.

Carry-over

High-to-low carry-over performance of Hemolyzer 3 NG.

Parameter	Carryover %
WBC	<1%
RBC	<1%
HGB	<1%
PLT	<1%

List of measured parameters

Parameter	Measured	Calculated	Calibrated
WBC	X		X
LYM, MID, GRA		X	X*
LYM%, MID%, GRA%		X	
RBC	X		X
HGB	X		X
HCT		X	
MCV	X		X
MCH		X	
MCHC		X	
RDWsd/RDWcv		X	X
PLT	X		X
MPV	X		X
PCT		X	
PDWsd/PDWcv		X	
PLC-R%		X	
PLC-C	X		X**

*calibrated by WBC factor

**calibrated by PLT factor

Known Limitations, interfering substances

Low PLT performance

Samples with extremely low PLT and (occasionally) elevated RBC counts may report falsely elevated PLT count due to some RBC being falsely identified as PLT. The possible interference can be detected if the RBC curve seems to reach into the PLT region, especially with high (near upper limit of normal value) RBC counts. In such cases, a manual smear should be used to verify the results.

PLT clumps

Some samples may contain PLTs that tend to form clumps and thus may be reporting low PLT values in an otherwise normal sample. This may be caused by the type of anti-coagulant or due to some medication that makes PLTs more likely to form clumps. Incorrect sample collection or failure to follow mixing immediately after taking the sample may also cause PLT clumps. If such condition was assumed, make sure to mix the sample thoroughly before running it in the analyzer again.

If clumps are suspected due to low PLT value, elevated MPV, indefinite valley between RBC and PLT populations or pseudo populations present beyond the RBC peak, then microscopic inspection of the sample is recommended. Please note that accurate PLT counts cannot be achieved if clumps were present.

HGB interference

Determination of the HGB value in a sample is based on a photometric measurement based on absorption of light of 540 nm wavelength through the lysed blood sample. HGB is related to the amount of light detected by the photometer. Any substance that may reflect or diffract light can have effect over the amount of light detected by the photometer by changing the amount of light detected. Lysis destroys RBC and leaves WBC and PLT in the solution. WBCs are much less in number so that they would not influence the amount of light detected by the photometer.

Particles (e.g. WBC) present in excess number will however act as tiny mirrors suspended in the liquid (sample) and can influence the amount of light detected. The analyzer is equipped with the necessary compensation algorithms to reliably provide HGB values unaffected by WBC count.

Some factors that cannot be detected by the device and thus accounted for may also interfere with the optical determination of HGB: lipemic samples where lipid particles can interfere with light intensity detection; samples with e.g. high bilirubin content may also have an incorrect HGB value determined due to the possible color interaction.

Anti-coagulant used

The anti-coagulant used for treating the sample has one of the most influencing effects over results. The right chemical, the correct amount and proper homogenization are all key factors to a reliable result. Using a lower amount of anti-coagulant may leave the sample partially clogged, resulting in PLT clumps; extensive amounts will dilute the sample, and can boost cell aging and degradation, some RBC may turn into burr-cells making MCV reading inaccurate. PLT clumps, coagulation, unstable, varying cell counts may also be the side effects. Not using anti-coagulant or using an improper sample collection vial may result in radical fluctuation of parameter values.

Sample age

Sample age also has a significant effect on results. Samples should be analyzed within 6 hours from sample collection. If samples cannot be analyzed within this time frame, then they should be stored refrigerated (2-8°C). Samples analyzed beyond 24 hours may suffer decrease in WBC and RBC counts, HCT value. HGB usually remains stable, yet PLT value may increase as a consequence of degrading blood cells.

Nucleated RBC (nRBC)

The name nRBC stands for nucleated RBC that are rarely present in blood samples taken from healthy patients. These cells are unmaturred RBC's and are found in the blood stream if there are some anomalies present in the process of blood production. Having a nucleus, these cells will still be detected after lysis – the nucleus may even remain in the size range of WBC. They may interfere with LYM counts by representing an additional population below or around the cell size of lymphocytes.

Electrical block diagram

Hemolyzer 3 NG is powered by an external power supply (input voltage range: 96-243VAC @ 47-64Hz output: 12 VDC, 5A).

Internal fuse: 3.5A at Power Input (SOURCE board).



WARNING

Only qualified service personnel may replace the internal fuse or the time keeping battery.

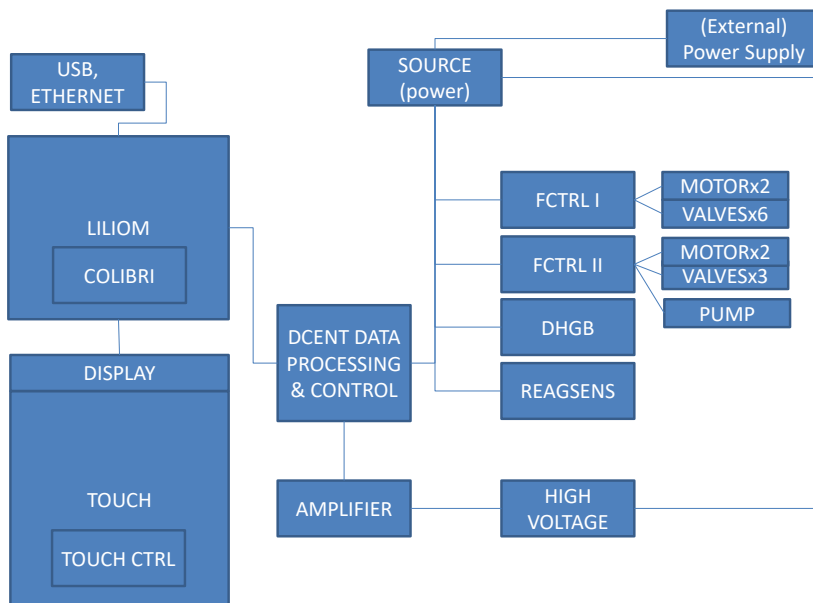

The main controlling board (Liliom) hosts a computer module (Colibri) which is connected to the LCD and the touch screen, and to the USB/Ethernet ports.

Motors, pumps and valves are controlled by 2 special boards (FCTRL I & II).

The impedance measurement signals are processed by the amplifier, and the DCENT board. DHGB board measures HGB.

SOURCE board receives and distributes power and displays analyzer status lights. It is also connected to the START button board.

Fluidic diagram

Hemolyzer 3 NG contains the following key fluidic components:

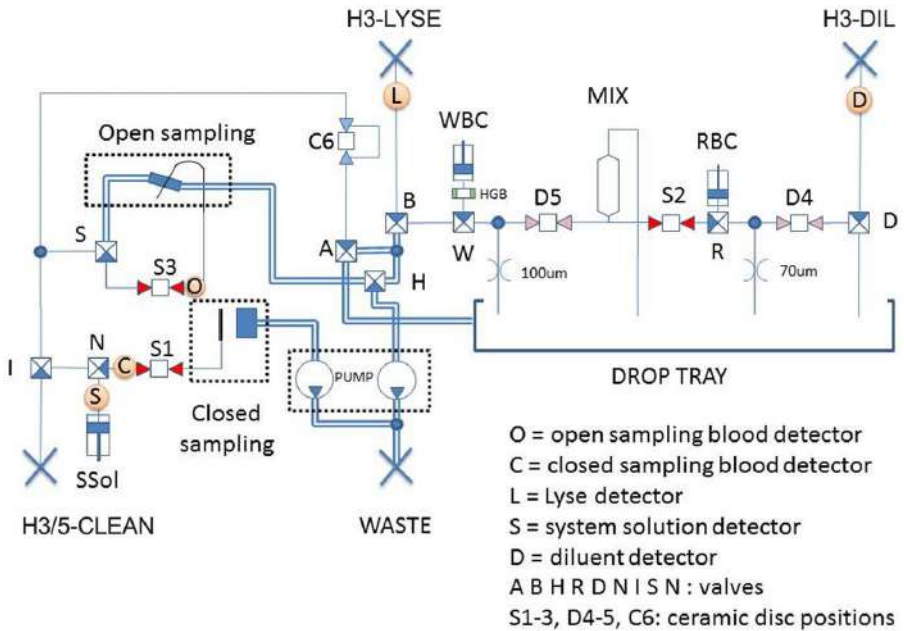

- Electronic boards (main board, signal processing boards, controller boards for moving components, display)
- 9 valves (A,B,D,H,I,N,R,S,W)
- A shear valve with sampling sections: S1-3, D4-5, C6
- Motors (syringe movement, ceramic valve movement, pump, sample rotor/sample unit),
- Measuring assembly incorporating ruby apertures (100µm/70µm)
- Peristaltic pump ("PUMP")
- Sample sensors (Open, Closed), reagent sensors: (DIL, LYSE, CLEAN)

	There are no user serviceable components inside the analyzer.
	Do not attempt to open the external covers to avoid damage to the system and avoid mechanical injury and can invalidate warranty.

Reagent consumption

All values are in ml (milliliter). Values indicate worst case aspirated volumes.

Process	H3-DIL	H3-LYSE	H3/5-CLEAN
Start-up (initial + wake up)	15.0	3.0	5.0
Start-up + FAST blank (typical consumption)	6.2	1.0	2.5
Measure FAST blank	3.0	0.5	0.0
Measure CLOSED sample	4.9	1.0	1.0
Measure OPEN sample	5.0	1.0	2.0
Switch to OPEN mode (from CLOSED mode)	0.0	0.0	1.0
Switch to CLOSED mode (from OPEN Mode)	0.0	0.0	1.0
Closed Cleaning	3.0	0.0	0.0
Open Cleaning	13.0	1.0	3.0
RBC Cleaning	13.0	1.0	3.0
Rinsing (aperture prime)	3.0	0.0	1.0
System Solution cleaning	6.0	1.0	3.0
Shear valve rinse	0.0	0.0	2.0
Prime H3-DIL	1.0	0.0	0.0
Prime H3-LYSE	0.0	1.0	0.0
Prime H3/5-CLEAN	0.0	0.0	3.0
Shut-down	2.0	0.0	2.0

Error messages

The software can report various errors in connection with results and operation. Error messages are displayed in a small pop-up bubble in the lower right corner of the screen. Errors have technical details which are useful when contacting Technical Support.

Technical Support will ask for diagnostic files to facilitate problem resolution.

Either have the analyzer connected to the Internet or have a USB storage device ready (formatted for FAT32 file system) for saving and emailing data.

Mechanical Errors

Error message	Reason for error	Remedy
Shear Valve error. An error occurred while testing Shear Valve backlash.	Mechanical Error	Rerun operation. If persists, contact Service.
An error occurred while attempting to use pump.	Pump not operating, pump jammed.	Rerun operation. If persists, contact Service.
Sampling Rotor error. An error occurred while attempting to use Sampling Rotor.	Mechanical error.	Rerun operation. If persists, contact Service. Check whether closed mode sampling opening is obstructed.
Sampling Rotor error. An error occurred while attempting to use Sampling Rotor (Sampling Rotor invalid position).	Mechanical error, sensor induced. Flexible tip might have been obstructed moving in/out.	Rerun operation. If persists, contact Service. Verify that tip can move freely.
Valve error. An error occurred while attempting to set valve.	Valve controller Error	Rerun operation. If persists, contact Service.
Shear valve recovery	The shear valve had problems moving, but the system resolved the error	Confirm, and run initialization. If possible, go to Management / Maintenance / Cleaning / Shear valve rinse

Operation related errors

Error message	Reason for error	Remedy
Communication error. An error occurred while sending an e-mail (connection exception).	No Internet access	Consult network administrator.
Control assay sheet already exists.	You scanned a sheet that has been scanned previously.	N/A
Communication error. An error occurred while attempting to download software upgrade file (unspecified error).	Network error.	Consult network administrator.
Communication error. An error occurred while attempting to connect to HL7 server (IP address? Port? Is the server running? Firewall?)	HL7 server did not reply for a message.	Check cable connection; verify HL7 settings; verify HL7 server status.
Network error. An error occurred while attempting to connect of HL7 server (Network cable is unconnected?).	There is no activity on the network.	Check cable connection, check network status. Verify IP (address) settings
Measurement error	General measurement error.	Contact service with error details.
QC LOT field cannot be empty.	You did not enter a LOT ID.	Enter a LOT ID.
QC with defined LOT already exists.		Verify LOT ID
An error occurred while decoding QR code (invalid or broken QC code).	QR code faulty.	Try scanning the sheet again. If you fail, load data from a file. Contact tech support for details.
Reagent detection error. An error occurred while attempting to calibrate reagent sensor at Diluent inlet.	Bubbles detected by sensor.	Check that reagent container is not empty.

Error message	Reason for error	Remedy
Reagent detection error. An error occurred while attempting to calibrate reagent sensor at Lyse inlet.	Bubbles detected by sensor.	Check that reagent container is not empty.
Reagent detection error. An error occurred while attempting to calibrate reagent sensor at System Solution inlet.	Bubbles detected by sensor.	Check that reagent container is not empty.
Tube Detector warning (missing condition).	Incorrect vial inserted in sample rotor.	Insert a correct tube.
Tube Detector warning (insert tube).	No vial detected.	Insert a tube, check for compatibility.
Tube Detector warning (remove tube).	A vial is detected in sample rotor, yet selected action requires the vial to be removed	Remove sampling vial.
Sampling Tip warning (active open mode).	Sampling tip could not be moved.	Check for obstruction. Run "Eject" from local menu.
Sampling Tip warning (inactive open mode).	Sampling tip could not be moved.	Check for obstruction. Run "Eject" from local menu.
User error	A vial got blocked, or was incorrectly inserted	Check for obstruction. Run "Eject" from local menu.
An error occurred while sending an e-mail (username or password exception).	Incorrect email data specified, or unsupported email client was set up.	Verify settings, contact network administrator. Observe and follow network and email setting instructions.
Sample aspiration error. Please rerun the sample. If the error persists, contact service	The system registered a possible blocked aspiration path (needle, or flexible tip).	Service can check and clean the relevant tubing sections.
Closed Wash Head maintenance required. To prevent damage to the system, closed measurement mode is disabled. Open mode is still available. Please contact service.	The waste liquid aspiration inside the system failed. To prevent further damage to the system, closed mode operation is disabled. Open mode remains operable.	Service needs to clean the closed sampling module. Contact Service.

Error message	Reason for error	Remedy
Closed Washing Head error. An error occurred while closing Washing Head at Shear Valve. Contact Service without executing any process except Eject Vial.	There is a mechanic jam inside the analyzer. To prevent damage to the system, the analyzer disables closed sampling mode.	Eject vial (if there was one inside when the error was displayed) and contact service. The unit cannot be used until the failure is resolved.

Electronic errors

Error message	Reason for error	Remedy
Camera error. An error occurred while activating camera.	The camera could not be detected.	Power off and on again. If the problem persists, use electronic files to load data. Contact service to schedule a visit.

System (software) errors

Error message	Reason for error	Remedy
Database error. An error occurred while attempting to read/write database.	Software error, corrupted file system.	The system will try to recover the error. If the error persists, contact Tech Support.
Database error. An error occurred while attempting to create record in database.	Software error, corrupted file system.	The system will try to recover the error. If the error persists, contact Tech Support.
Communication error. An error occurred while attempting to read/write ProductID.	A key system element is missing.	Contact Tech Support.
Fluidics error. An unknown low-level error occurred while attempting to execute fluidics function.	A key system element is missing or is malfunctioning.	Contact Tech support for guidance.

Error message	Reason for error	Remedy
Fluidics error. An unknown error occurred while attempting to execute fluidics function.	A key system element is missing or is malfunctioning.	Contact Tech support for guidance.
Fluidics error. An unknown error occurred while attempting to get/set arguments of fluidics subsystem.	A key system element is missing or is malfunctioning.	Contact Tech support for guidance.
Processing error. An error occurred while attempting to process raw measurement data.	A key system element is missing or is malfunctioning.	Contact Tech support for guidance.
System error. An error occurred while attempting to query active QC LOT.	A key system element is missing or is malfunctioning.	Contact Tech support for guidance.
Communication error. An error occurred while attempting to open serial port.	A key system element is missing or is malfunctioning.	Contact Tech support for guidance.
System error. An error occurred while attempting to play sound file.	A key system element is missing or is malfunctioning.	Contact Tech support for guidance.
Communication error. An error occurred while attempting to print with thermal printer.	The printer is not connected. A key system element is missing or is malfunctioning.	Connect the printer. Contact Tech support for guidance.
Reagent detection error. An error occurred while attempting to detect Diluent.	A key system element is missing or is malfunctioning.	Contact Tech support for guidance.
Exporting error. An error occurred while attempting to export Tab Separated File.	No USB storage device attached. A key system element is missing or is malfunctioning.	Connect USB storage device Contact Tech support for guidance.
Communication error. An error occurred while attempting to send e-mail (unspecified error).	A key system element is missing or is malfunctioning.	Contact Tech support for guidance.

Error message	Reason for error	Remedy
An error occurred while attempting to set volume.	A key system element is missing or is malfunctioning.	Contact Tech support for guidance.
Software error	A key system element is missing or is malfunctioning.	Contact Tech support for guidance.
System error	A key system element is missing or is malfunctioning.	Contact Tech support for guidance.
System error. An error occurred while attempting to initiate system (unspecified error).	A key system element is missing or is malfunctioning.	Contact Tech support for guidance.
Reagent detection error. An error occurred while attempting to detect Lyse.	A key system element is missing or is malfunctioning.	Contact Tech support for guidance.
Reagent detection error. An error occurred while attempting to detect System Solution.	A key system element is missing or is malfunctioning.	Contact Tech support for guidance.
Reagent system error. An error occurred while attempting to activate reagent (expired).	A key system element is missing or is malfunctioning.	Contact Tech support for guidance.
System error. An error occurred while attempting to modify reagent's tracking level.	A key system element is missing or is malfunctioning.	Contact Tech support for guidance.
System error. An error occurred while attempting to query active reagents (inactive or expired reagents).	A key system element is missing or is malfunctioning.	Contact Tech support for guidance.
Reagent detection error. An error occurred while attempting to read reagent sensor data.	A key system element is missing or is malfunctioning.	Contact Tech support for guidance.
Firmware Error	A key system element is missing or is malfunctioning.	Contact Tech support for guidance.

Error message	Reason for error	Remedy
Remote Management error	IP address of Access Server is incorrect, or a Firewall blocks connection	Contact Service for proper setup
Hemolyzer 3 NG recovered after internal error. You can continue your work.	A software error forced the system to reinitialize the User Interface	No action required. Continue work. The restart process will turn the screen off and standard startup sequence is visible.
Database verified and fixed.	A database error was found at startup, and the software could successfully fix the problem.	No action required.

Troubleshooting

Measurement problems

Symptom	Possible cause	Remedy
High BLANK values	Contaminated reagents Cold reagents Unearthed power outlet Minor internal contamination	Replace reagents Make sure reagents reached room temperature Connect power supply to grounded power outlet or connect ground to chassis of analyzer Repeat FastBlank 3-4 times
Missing reagents, wrong results	One reagent is out Reagents are not connected Reagent connector sealing failure	Replace reagents Verify reagent connector Replace reagent pack, or replace connector Prime reagents. Look for bubbles in the tubes outside the analyzer
Incorrect WBC differentiation	Lysing reagent errors	Check reagent connector, prime Lyse reagent 2-3 times.
Low sample volume reported	Too low blood sample volume Open mode Closed mode	Run vials with correct sample volume Make sure you run open sampling correctly: remove vial only after Hemolyzer 3 NG signals to. Check minimum sample volume (300µl). Run closed cleaning. If the problem persists, contact Service
Leakage from rear reagent connector	Reagent connector sealing failure	Replace reagents Verify reagent connector Replace reagent pack, or replace connector
Noise flags	Bubbles are trapped inside critical tubes.	Run Rinsing 2-3 times (Management/Maintenance/Cleaning).
Lysing flags (improper lysing)	Reagent insufficiency	Prime DIL and LYSE If the problem persists, contact Service.

Symptom	Possible cause	Remedy
Improper voltage	Reagent insufficiency, or block inside the analyzer	Prime DIL and LYSE Run Rinsing, Open Cleaning functions If the problem persists, contact Service.
Unstable voltage	Reagent or sample insufficient. Partial clogging of the system	Run Rinsing and Open cleaning. Run RBC cleaning (if RBC/PLT values are affected) Inform Service
Dirty WBC channel error	Electrodes “dirty”: buildup due to high sample load	Run Open cleaning

Electrical problems

Symptom	Possible cause	Remedy
Instrument cannot be powered on	Power is not connected Power voltage is too high, or too low Fuse is blown inside analyzer	Connect power source, verify connections Replace / check power supply (is LED on?) Contact Service
Indicator on top/front of the analyzer glows in RED or BLUE color BEFORE power ON	Power voltage is too high/low	Replace power supply
Instrument powers down during operation	Power system fluctuations	Try to start the analyzer again. Use a UPS. Contact Service
Software error message	Corrupted SW system.	Contact Service
Touch screen does not react to gestures	Faulty touch screen	Connect an external mouse for temporary operation. Contact Service
Uncertain operation of touch screen	Faulty touch screen	Connect an external mouse for temporary operation. Contact Service

Mechanical problems

Symptom	Possible cause	Remedy
Sample vial is stuck in sample rotor	Power outage during operation Oversized vial, vial stuck Mechanical Problem	Start analyzer again, initiate measurement sequence Go to local menu (HOLD any point on the screen) and initiate "Eject" Mechanical error. Contact Service
Sample vial is not lowered, system reports missing tube, yet tube and cap are present	Cap detector failure.	Contact Service Use OPEN mode as workaround
Sample vial is not returned to operator	Vial is stuck on sampling needle Mechanical error (strong noise)	Start analyzer again, initiate measurement sequence. Go to local menu (HOLD any point on the screen) and initiate "Eject" Contact Service
Grinding noise from inside of analyzer	Mechanical blocking	Try to rerun the operation. If the problem persist, then contact Service
Analyzer reports empty measurements	Too low blood sample volume Clogged sampling paths	Run vials with correct sample volume Rerun sample. Contact Service
Leakage beneath analyzer	Blocked sampling valve/needle system Leaking reagent connector	Try running system cleaning. If it still fails, contact Service Check reagent connector

Hydraulic problems

Symptom	Possible cause	Remedy
Instrument reports clogging	Bad quality sample used	Try to initiate a measurement. Built in functions will attempt to unclog needle and apertures. Run system cleaning (Open Cleaning). If the problem persists, contact Service
Flexible sampling tube is not pushed out during open tube sampling	Tube has been pushed in by user, or movement is blocked. Tube was bent/broken by user, tube cannot be pushed out	Try to restart analyzer. Contact Service
Leakage from the wash head of the open tube sampling	Clogging in washing head, salt crystals. Pump failure. Kinked external waste tube.	Clean washing head. Check external reagent tubes. If it still fails, contact Service

Network problems

Symptom	Possible cause	Remedy
Network error message at the end of every sample	HL7 or email communication is enabled (forced) but settings/network does not comply.	Verify HL7 / email settings. Disable email (clear account data) or clear HL7 settings
Remote Management error message	Remote Management data are incorrect	Contact Service for correct settings
WIFI dongle not recognized	Driver error	Check supported list of WIFI chipsets

Printer problems

Symptom	Possible cause	Remedy
Scrambled printout	Incorrect printer model	Use Printers with PLC5 or ESC/POS language support
Empty pages printed	Incorrect printer model	Install compatible printer. Contact Service for instructions
Printer connected, but no printer icon in top row of Hemolyzer 3 NG screen	Printer is not supported, USB cable wrong Printer is OFF	Test the printer and USB cable with a PC. Restart Hemolyzer 3 NG. Make sure to use the same grounded electrical outlet for Hemolyzer 3 NG and peripherals. Test USB sockets with an external Keyboard or with a USB stick (and try to save diagnostic files to the USB)

Directives and Standards

Hemolyzer 3 NG complies with the following directives and standards as listed below.

Norm	Title
ISO 9001*	Quality management systems - Requirements
ISO 13485*	Medical devices - Quality management systems - Requirements for regulatory purposes
ISO 14971*	Medical devices - Application of risk management to medical devices
ISO 15223-1*	Medical devices - Symbols to be used with medical device labels, labelling and information to be supplied - Part 1: General requirements
ISO 18113-1*	In vitro diagnostic medical devices - Information supplied by the manufacturer (labelling) - Part 1: Terms, definitions and general requirements
ISO 18113-3*	In vitro diagnostic medical devices - Information supplied by the manufacturer (labelling) - Part 3: In vitro diagnostic instruments for professional use
IEC/EN 61010-1	Safety requirements for electrical equipment for measurement, control and laboratory use - Part 1: General requirements
IEC/EN 61010-2-101*	Safety requirements for electrical equipment for measurement, control and laboratory use – Part -101: Particular requirements for in vitro diagnostic (IVD) medical equipment
IEC/EN 61326-2-6*	Electrical equipment for measurement, control and laboratory use – EMC requirements – Part 2-6: Particular requirements – In vitro diagnostic (IVD) medical equipment
EN 13612*	Performance evaluation of in vitro diagnostic medical devices
EN 62304*	Medical device software — Software life cycle processes

*harmonized Standards according to Directive 98/79/EC

EU Regulation	Title
Directive 98/79/EC	on in vitro diagnostic medical devices
Directive 2011/65/EU (RoHS2)	on the restriction of the use of certain hazardous substances in electrical and electronic equipment

Hypochlorite Solution

▶ Product Information ◀

Product name	Product code
H3/5-Hypoclean	HE3413

▶ Product Content ◀

HE3413	
H3/5-Hypoclean	5x100 mL
Instructions for Use	1 pc

▶ Intended Use and Test Principle ◀

H3/5-Hypoclean detergent is a stabilized and micro-filtered hypochlorite solution for intensive oxidative rinsing and cleaning of capillaries, tubing, and chambers of Hemolyzer[®] semi-automated hematology analyzers.

The detergent is intended for laboratory professional use as an in vitro diagnostic medical device.

▶ Detergent Preparation ◀

The product is ready to use, please follow the installation procedures of this instructions for use.

▶ Product Composition ◀

	H3/5-Hypoclean
Detergents	< 0.1 %
Sodium hypochlorite	< 5.0 %
Stabilizers	< 0.1 %
Sodium hydroxide	< 1.0 %
Ion-free water	> 93.8 %



▶ Warnings and Precautions ◀

- Read instructions for use carefully before use.
- Do not use the product beyond the expiry date.
- Do not use the product if the primary package is damaged or there is visible sign of chemical deterioration of the liquid inside. In both cases the product should be replaced.
- Always keep the detergent in its original container.
- Store at the recommended temperature range.
- Do not use the product if it has been frozen or kept at excessive heat. Use the product at room temperature (18-30°C). If it has been stored below 18°C or above 30°C, leave it at normal room temperature for 3 hours before use.
- Do not mix the remains of a detergent with another container.
- Do NOT place the product above the instrument or on the ground! Place it on the same level as the analyzer.
- Users are advised to wear approved protective clothing when handling chemical products: lab coat, gloves, and eye protection.
- Observe standard laboratory precautions for use and follow national or local health and safety guidelines.
- Avoid contact with eyes, skin, and clothing. In case of contact with eyes or skin, rinse immediately with plenty of water.
- Please refer to the product's Safety Data Sheet.
- Please report any serious incident involving the product to the manufacturer and the competent local authority.

▶ Storage and Shelf Life ◀

- Storage conditions: **2-35°C**.
- Shelf life: **2 years**.
- Open bottle stability: **6 months**.
- Expiry date: **refer to the product's labeling**.

▶ Waste Management ◀

Dispose waste product, unused product, and contaminated packaging in compliance with local regulations.

► How to Use: Hemolyzer® 3 NG ◀

Materials required but not provided

- Hemolyzer® 3 NG hematology analyzer.
- Empty cleaning tube.

Cleaning procedure

The detergent is used to perform weekly maintenance procedures on the Hemolyzer® 3 NG hematology analyzer, such as closed sampling cleaning, open sampling cleaning, rinsing and RBC cleaning. When cleaning is required, the calendar icon will appear on the screen.



To perform these regular cleaning procedures, tap on »Management« in the main menu, then go to the “Cleaning” submenu. Please follow the instructions on the analyzer. The software guides you through the cleaning processes.

► How to Use: Hemolyzer® 5 NG ◀

Materials required but not provided

- Hemolyzer® 5 NG hematology analyzer.
- Reagent pickup tubes and caps.

Detergent installation precautions

- Person installing the detergent must be trained laboratory professional.
- Use the reagent pickup tubes and caps supplied with the instrument.
- Clean the pickup tubes by wiping them from top to bottom, using lint-free tissue dampened with distilled water. Avoid any dust or microbial contamination of the tubing and detergent.

Cleaning procedure













The detergent is used to perform RBC Hard Clean cleaning procedure on the Hemolyzer® 5 NG hematology analyzers. Performing the cleaning is recommended if the analyzer reports 5 consecutive samples with Contamination flag.

To perform RBC Hard Clean, tap on »Management« in the main menu, then go to the “Cleaning” submenu. There are two different cleaning options to choose from depending on which reagent pickup tube set is in use:

- Cleaning with old tubing set – without Quick Lock
- Cleaning with new tubing set – with Quick Lock

Please follow the instructions on the analyzer. The software guides you through the cleaning processes.

► Explanation of Symbols ◀

	Catalogue number		Batch number
	Expiry date		In vitro diagnostic medical device
	Permitted storage temperature		CE mark
	See the instructions for use		Manufacturer
	Corrosion – causes severe skin burns and eye damage.		Content
	Date of manufacture		Distributor

H3-Check

Hemolyzer® 3 NG Control Set



Order information:

Catalog-No.	Article name	Content
HE3504	H3-Check Complete	6 x 2.5 mL (L, N, H)
HE3505	H3-Check Normal	6 x 2.5 mL (N)

Intended Use:

H3-Check Control Sets are intended for quality control measurements on the Analyticon hematology analyzer Hemolyzer® 3 NG (open and closed mode) (HE3100), and serve to validate the measurement results.

Reagents:

The H3-Check Control Set contains human erythrocytes, simulated leukocytes, and mammalian platelets suspended in a plasma-like fluid with preservatives. For lot-specific target values, please refer to the table below.

Warning and Precautions:

For in vitro diagnostic use only.

For trained laboratory professional only.



All body fluid samples should be considered potentially infectious materials. The product was tested negative against anti-HIV 1 and 2, anti-HCV and HBsAg, but since no test method can rule out the danger of infection with absolute certainty, treat all blood and other potentially infectious materials with appropriate precautions. Use gloves, masks and gowns if blood exposure is anticipated.

Exercise the normal precautions required for handling all laboratory reagents. Disposal of the product should be in accordance with local regulations. The material safety data sheet contains further safety-related information. It is available for download from our homepage <http://www.analyticon-diagnostics.com>.

Storage and Stability:

Unopened tube	Until the expiration date	2 – 8 °C
Opened tube	14 days	2 – 8 °C

Store the tubes in upright position. Do not freeze!

Indications of Deterioration:

After mixing, product should be similar in appearance to fresh whole blood. In unmixed vials, the supernatant may appear cloudy and reddish, which is normal and does not indicate deterioration. Other discoloration, very dark red supernatant or unacceptable results may indicate deterioration. Do not use the product if deterioration is suspected.

Procedure:

1. Allow the tubes to warm to room temperature (15 to 30 °C) for at least 15 minutes.
2. Prior to the first use of the control, make sure to open the cap, and gently tighten it back ensuring no leaks. Do not overtighten the cap, otherwise you may experience needle clogs.
3. Invert the tubes for at least 20–30 seconds to mix the control material thoroughly. The red precipitate at the bottom of the tube has to be completely suspended and the red color of the fluid needs to be evenly distributed. Tubes stored for a long time might require longer mixing.
4. Gently invert the tube 8–10 times immediately before sampling and analyze the sample as instructed in the Quality Control section of the Operator's Manual for your instrument.
5. If the tube has been open for sampling, clean residual material from the cap and tube rim with a lint-free tissue after the sampling. Close the cap tightly.
6. Return the tubes to refrigerator (2–8 °C) within 30 minutes of use.

Results and Expected Values:

Verify that the lot number on the tube matches the lot number on the table of target values.

Target values are determined on well-maintained, properly calibrated instruments using the instrument manufacturer's recommended reagents. The "Expected Range" takes inherent imprecision of the method and expected biological variability of the control material into account.

Minor variations may derive from different reagent batches, maintenance status, operating technique, and calibration and might contribute to inter-laboratory variation.

For greater control sensitivity, it is recommended that each laboratory establishes its own target value and expected range, and periodically re-evaluates the target value. The expected range of the laboratory may include values outside of the expected range given by the manufacturer.

Limitations of the Procedure:

The performance of this product is assured only if it is properly stored and handled as described in this insert. Incomplete mixing of a tube prior to use invalidates both the sample withdrawn and any remaining material in the tube.

Control vials can be pierced maximum 40 times. After that the rubber part of the cap has the risk of dropping into the control, causing clogs in the instrument.



H3-Check

Hemolyzer® 3 NG Control Set



Bestellinformation:

Katalog-Nr.	Artikelname	Inhalt
HE3504	H3-Check Complete	6 x 2,5 mL (L, N, H)
HE3505	H3-Check Normal	6 x 2,5 mL (N)

Anwendungszweck:

Die H3-Check Kontrollsets sind für Qualitätskontrollmessungen an dem Analyticon Hämatologie Analysegerät Hemolyzer® 3 NG (open und closed mode) (HE3100) vorgesehen und dienen zur Validierung der Messergebnisse.

Reagenzien:

Das H3-Check Kontrollset enthält humane Erythrozyten, künstliche Leukozyten und Blutplättchen von Säugetieren in einer Plasma-ähnlichen Flüssigkeit mit Konservierungsmitteln. Für Lot-spezifische Zielwerte, beziehen Sie sich bitte auf die Tabelle am Ende des Textes.

Warn- und Vorsichtshinweise:

Nur zum Gebrauch als in vitro Diagnostikum.

Anwendung nur durch geschultes Laborpersonal.



Alle Körperflüssigkeiten sollten als potentiell infektiöses Material betrachtet werden. Das Produkt wurde negativ auf anti-HIV 1 und 2, anti-HCV und HBsAg getestet, doch da keine Testmethode das Risiko einer Infektion mit absoluter Sicherheit ausschließen kann, behandeln Sie alle Blutproben und andere potentiell infektiöse Materialien mit den entsprechenden Vorsichtsmaßnahmen. Verwenden Sie Handschuhe, Atemschutz und Laborkleidung, falls der Kontakt mit Blut zu erwarten ist.

Die beim Umgang mit Laborreagenzien üblichen Vorsichtsmaßnahmen beachten. Bei der Entsorgung des Produktes müssen die jeweiligen gesetzlichen Vorschriften beachtet werden.

Weitere sicherheitsrelevante Informationen sind im Sicherheitsdatenblatt enthalten. Dieses steht auf unserer Homepage <http://www.analyticon-diagnostics.com> zum Download bereit.

Lagerung und Stabilität:

Ungeöffnetes Röhrchen	Bis zum Ende des Haltbarkeitsdatums	2 – 8 °C
Geöffnetes Röhrchen	14 Tage	2 – 8 °C

Lagern Sie die Röhrchen in aufrechter Position. Nicht einfrieren!

Anzeichen von Verfall des Produktes:

Nach dem Mischen sollte das Produkt ein ähnliches Aussehen wie frisches Vollblut aufweisen. In ungemischten Röhrchen kann der Überstand wolkig rötlich erscheinen, was normal und kein Zeichen von Verfall ist. Andere Verfärbungen, ein sehr dunkelroter Überstand oder unerwartete Ergebnisse können Zeichen von Verfall sein. Verwenden Sie das Produkt nicht, wenn Sie Verfall vermuten.

Vorgehen:

1. Geben Sie den Röhrchen mindestens 15 Minuten Zeit, um Raumtemperatur (15 bis 30 °C) zu erreichen.
2. Achten Sie darauf, dass die Kappe der Kontrolle vor dem ersten Gebrauch geöffnet und vorsichtig wieder angezogen wird, um Undichtigkeiten zu vermeiden. Ziehen Sie die Kappe nicht zu fest an, da es sonst zu Verstopfungen der Nadel kommen kann.
3. Invertieren Sie die Röhrchen für mindestens 20–30 Sekunden, um das Kontrollmaterial gründlich durchzumischen. Der rote Niederschlag auf dem Boden der Röhrchen muss vollständig aufgelöst und die rote Farbe der Flüssigkeit gleichmäßig verteilt sein. Röhrchen, die für längere Zeit gelagert wurden, bedürfen eventuell längerem Mischen.
4. Invertieren Sie die Röhrchen kurz vor der Probenahme noch einmal 8–10 Mal. Messen Sie die Proben wie in dem Kapitel zur Qualitätskontrolle in Ihrem Gerätehandbuch beschrieben.
5. Falls das Röhrchen während der Probenentnahme geöffnet worden ist, reinigen Sie die Kappe und den Rand des Röhrchens mit einem fusselfreien Tuch, bevor Sie es wieder fest verschließen.
6. Stellen Sie die Röhrchen innerhalb von 30 Minuten wieder kühl (2–8 °C).

Ergebnisse und Zielwerte:

Stellen Sie sicher, dass die Lot Nummern auf den Röhrchen und der Tabelle mit Zielwerten übereinstimmen. Die Zielwerte wurden auf gut gewarteten, sorgfältig kalibrierten Analysegeräten mit den vom Hersteller empfohlenen Reagenzien bestimmt. Der akzeptable Bereich bezieht die inhärente Ungenauigkeit der Methode und die erwartete biologische Variabilität des Kontrollmaterials mit ein.

Verschiedene Reagenzchargen, Wartungsstatus, Durchführung und Kalibration können geringe Schwankungen ergeben, die zu Abweichungen zwischen verschiedenen Laboren beitragen.

Um eine erhöhte Kontrollsensitivität zu erreichen, wird empfohlen, eigene Sollwerte und einen akzeptablen Bereich zu bestimmen und diesen regelmäßig zu bestätigen. Der akzeptable Bereich des einzelnen Labors kann Werte außerhalb des akzeptablen Bereiches des Herstellers enthalten.

Einschränkungen der Anwendung:

Die Leistung dieses Produktes ist bei ordnungsgemäßer Lagerung und Handhabung sichergestellt. Ungenügendes Mischen vor der Verwendung macht die eingesetzte Probe und das verbliebene Material im Probenröhrchen unbrauchbar.

Der Gummiteil der Kappe des Kontrollröhrchens kann maximal 40 Mal durchstochen werden. Danach besteht die Gefahr, dass Gummiteile der Kappe in die Kontrolle fallen und im Anschluss das Gerät verstopfen.

Grau hinterlegte Textpassagen wurden in der letzten Überarbeitung dieser Gebrauchsanweisung geändert.



H3-Check

Hemolyzer® 3 NG Control Set



Información del pedido:

No. de Catálogo	Nombre del artículo	Contenido
HE3504	H3-Check Complete	6 x 2,5 mL (L, N, H)
HE3505	H3-Check Normal	6 x 2,5 mL (N)

Uso previsto:

H3-Check Control Sets están diseñados para las mediciones de control de calidad en los analizadores hematológicos Analyticon Hemolyzer® 3 NG (modo abierto y cerrado) (HE3100) y se utilizan para validar los resultados de la medición.

Reactivos:

El H3-Check Control Set contiene eritrocitos humanos, leucocitos simulados y plaquetas de mamífero suspendidas en un líquido similar al plasma con conservantes. Para los valores previstos específicos del lote, consulte la tabla siguiente.

Advertencias y precauciones:

Solamente para uso en diagnóstico in vitro.

Sólo para uso del profesional de laboratorio capacitado.



Todas las muestras de fluidos corporales deben considerarse materiales potencialmente infecciosos. El producto dio negativo contra el VIH 1 y 2, el VHC y el HBsAg, pero como ningún método de prueba puede descartar el peligro de infección con absoluta certeza, trate toda la sangre y otros materiales potencialmente infecciosos con las precauciones adecuadas. Use guantes, máscaras y batas si se prevé la exposición a la sangre.

Siga las precauciones habituales requeridas al manipular todos los reactivos de laboratorio. La eliminación del producto debe realizarse de acuerdo con las normativas locales.

La ficha de datos de seguridad de materia contiene mayor información relacionada a la seguridad. Disponible en nuestro sitio <http://www.analyticon-diagnostics.com>.

Almacenamiento y estabilidad:

Envase sin abrir	Hasta la fecha de vencimiento	2 – 8 °C
Envase abierto	14 días	2 – 8 °C

Guarde los tubos en posición vertical. ¡No congelar!

Indicaciones de deterioro:

Después de mezclar, el producto debe tener un aspecto similar al de la sangre entera fresca. En viales no mezclados, el sobrenadante puede aparecer turbio y rojizo; esto es normal y no indica deterioro. Otra decoloración, un sobrenadante de color rojo muy oscuro o resultados inaceptables pueden indicar deterioro. No utilice el producto si sospecha que está deteriorado.

Procedimiento:

1. Dejar que los tubos alcancen la temperatura ambiente (de 15 a 30 ° C) durante al menos 15 minutos.
2. Asegúrese de abrir la tapa del tubo del control antes del primer uso y vuelva a apretarla suavemente para evitar fugas. No apriete demasiado la tapa, ya que esto podría bloquear la aguja.
3. Invierta los tubos durante al menos 20-30 segundos para mezclar bien el material de control. El precipitado rojo en el fondo del tubo tiene que estar completamente suspendido y el color rojo del fluido tiene que ser distribuido uniformemente. Los tubos almacenados durante mucho tiempo pueden requerir una mezcla más larga.
4. Invierta suavemente el tubo de 8 a 10 veces inmediatamente antes del muestreo y analice la muestra como se indica en la sección de Control de Calidad del Manual del Operador de su instrumento.
5. Si el tubo ha sido abierto para el muestreo, limpie el material residual de la tapa y el borde del tubo con un pañuelo sin pelusa después del muestreo. Cierre bien la tapa.
6. Regrese los tubos al refrigerador (2–8 ° C) dentro de los 30 minutos de uso.

Resultados y valores esperados:

Verifique que el número de lote en el tubo coincida con el número de lote en la tabla de valores objetivo.

Los valores objetivo se determinan en instrumentos bien mantenidos y debidamente calibrados utilizando los reactivos recomendados por el fabricante del instrumento. El "Rango esperado" tiene en cuenta la imprecisión inherente del método y la variabilidad biológica esperada del material de control.

Las variaciones menores pueden derivarse de diferentes lotes de reactivos, estado de mantenimiento, técnica operativa y calibración, y pueden contribuir a la variación entre laboratorios.

Para una mayor sensibilidad de control, se recomienda que cada laboratorio establezca su propio valor objetivo y rango esperado, y que reevalúe periódicamente el valor objetivo. El rango esperado del laboratorio puede incluir valores fuera del rango esperado dado por el fabricante.

Limitaciones del procedimiento:

El rendimiento de este producto sólo está garantizado si se almacena y manipula correctamente tal y como se describe en este prospecto. La mezcla incompleta de un tubo antes de su uso invalida tanto la muestra extraída como cualquier material remanente en el tubo.

La parte de goma de la tapa del tubo del control puede perforarse un máximo de 40 veces. Después de esto existe el riesgo de que las partes de goma de la tapa caigan en el control pudiendo obstruir posteriormente el dispositivo.

Los pasajes de texto con fondo gris se cambiaron en la última revisión de este prospecto.



H3-Check

Hemolyzer® 3 NG Control Set



Информация для заказа:

№. по каталогу	Название изделия	Содержимое
HE3504	H3-Check полный	6 x 2,5 мл (L, N, H)
HE3505	H3-Check нормальный	6 x 2,5 мл (N)

Предназначенное использование:

Контрольные наборы H3-Check предназначены для контроля качества измерений на гематологических анализаторах компании «Analyticon» Hemolyzer® 3 NG (закрытый и открытый режим) (HE3100) и для валидации результатов их измерений.

Реагенты:

Контрольный набор H3-Check состоит из эритроцитов человека, имитированных лейкоцитов и тромбоцитов млекопитающих, суспендированных в сходной с плазмой жидкости с консервантами. Для заданных значений лотов, пожалуйста, обратитесь к таблице ниже.

Предупреждение и меры предосторожности:

Только для диагностики in vitro.

Только для обученных лабораторных специалистов



Все образцы жидкостей организма должны рассматриваться как потенциально инфекционные материалы. Были получены отрицательные результаты в испытаниях продукта в отношении анти- HIV 1 и 2, анти-HCV и HBsAg, но, поскольку ни один метод тестирования не может исключить опасность инфекции с абсолютной уверенностью, обрабатывайте всю кровь и другие потенциально инфекционные материалы с соответствующими мерами предосторожности. Используйте перчатки, маски и халаты, если предполагается возможное попадание крови.

Соблюдайте обычные меры предосторожности, необходимые для работы со всеми лабораторными реагентами. Утилизация продукта должна осуществляться в соответствии с местными правилами.

Паспорт безопасности материала содержит дополнительную информацию, касающуюся безопасности. Ее можно загрузить с нашей домашней страницы <http://www.analyticon-diagnostics.com>.

Хранение и стабильность:

Неоткрытая пробирка	до истечения срока годности	2 - 8 ° C
Открытая пробирка	14 дней	2 - 8 ° C

Хранить пробирки в вертикальном положении. Не замораживать!

Признаки повреждения продукта :

После смешивания продукт должен быть внешне похож на свежую цельную кровь. В несмешанных флаконах супернатант может выглядеть мутным и красноватым, что является нормальным и не указывает на повреждение. Другие изменения цвета, очень темно-красный супернатант или неприемлемые результаты могут указывать на повреждение. Не используйте продукт, если есть подозрение на его повреждение.

Процедура:

1. Дайте пробиркам согреться до комнатной температуры (от 15 до 30 ° C) в течение не менее 15 минут.
2. Обратите внимание на следующее, перед первым использованием убедитесь, что крышка Контроля открыта и осторожно затяните ее назад, чтобы избежать утечек. Не затягивайте колпачок слишком сильно, так как это может привести к засорению иглы
3. Переверачивайте пробирки в течение не менее 20–30 секунд, чтобы полностью перемешать контрольный материал. Красный осадок на дне пробирки должен быть полностью растворён, а красный цвет жидкости должен быть равномерно распределен. Пробирки, хранящиеся в течение длительного времени, могут потребовать более длительного перемешивания.
4. Осторожно переверните пробирку 8–10 раз непосредственно перед отбором образцов и проанализируйте образец, как указано в разделе «Контроль качества» руководства по эксплуатации вашего прибора.
5. Если пробирка открыта для отбора образцов, то после отбора образцов удалите остатки материала с крышки и края пробирки безворсовой тканью. Закройте плотно крышку.
6. Верните пробирки в холодильник (2–8° C) в течение 30 минут после использования.

Результаты и ожидаемые значения:

Убедитесь, что номер лота на пробирке соответствует номеру лота в таблице заданных значений.

Заданные значения определяются на приборах в хорошем состоянии, с соответствующим техническим обслуживанием и правильно откалиброванных с использованием рекомендованных производителем реагентов. «Ожидаемый диапазон» учитывает внутреннюю неточность метода и ожидаемую биологическую изменчивость контрольного материала.

Незначительные отклонения могут быть вызваны различными партиями реагентов, состоянием технического обслуживания, техникой эксплуатации и калибровкой, и могут способствовать межлабораторной вариации.

Для большей чувствительности контроля рекомендуется, чтобы каждая лаборатория устанавливала свое собственное заданное значение и ожидаемый диапазон, а также периодически повторно оценивала заданное значение. Ожидаемый диапазон конкретной лаборатории может включать в себя значения за пределами ожидаемого диапазона, указанного производителем

Ограничения процедуры:

Характеристики этого продукта гарантируются, только если он правильно хранится и обрабатывается, как описано в этом вкладыше. Неполное размещение пробирки перед использованием делает непригодным для использования как отобранный образец, так и любой остаточный материал в пробирке.

Контрольные флаконы можно проколоть максимум 40 раз. После существует опасность, что резиновая часть колпачка может упасть в контрольный флакон, что приведет к засорению прибора.

Текстовые фрагменты с серым фоном были изменены в последней редакции этой инструкции.



H3/5-Cal

Hemolyzer® NG Calibrator



Order information:

Catalog-No.	Article name	Content
HE3611	H3/5-Cal	1 x 2.5 mL

Intended Use:

H3/5-Cal is intended for the calibration of Analyticon hematology analyzers Hemolyzer® 3 NG (HE3100) and Hemolyzer® 5 NG (closed and open mode) (HE5100 and HE5200).

Summary and Explanation:

Hematology analyzers require periodic calibration in order to generate accurate patient results. This calibrator is a stable, whole blood preparation that can be used to verify and adjust calibration of select hematology instruments.

Reagents:

The H3/5-Cal is composed of human erythrocytes, mammalian leukocytes and mammalian platelets suspended in a plasma-like fluid with preservatives. For lot-specific concentrations, please refer to the table below.

Warning and Precautions:

For in vitro diagnostic use only.
For trained laboratory professional only.



All body fluid samples should be considered potentially infectious materials. The product was tested negative against anti-HIV 1 and 2, anti-HCV and HBsAg, but since no test method can rule out the danger of infection with absolute certainty, treat all blood and other potentially infectious materials with appropriate precautions. Use gloves, masks and gowns if blood exposure is anticipated.

Exercise the normal precautions required for handling all laboratory reagents. Disposal of the product should be in accordance with local regulations. The material safety data sheet contains further safety-related information. It is available for download from our homepage <http://www.analyticon-diagnostics.com>.

Storage and Stability:

Unopened tube	Until the expiration date	2 – 8 °C
Opened tube	5 days	2 – 8 °C

Store the tubes in upright position. Do not freeze!

Indications of Deterioration:

After mixing, product should be similar in appearance to fresh whole blood. In unopened vials, the supernatant may appear cloudy and reddish, which is normal and does not indicate deterioration. Other discoloration, very dark red supernatant or unacceptable results may indicate deterioration.

If result of the calibrator is outside the range found on the assay sheet whereas the control results and interlaboratory QC are stable, and/or the Proficiency Testing reports have excellent peer group agreement, this may indicate possible product damage.

Do not use the product if deterioration is suspected.

Procedure:

Mixing and Sampling:

- Allow the tubes to warm to room temperature (15 to 30 °C) for at least 15 minutes.
- Prior to the first use of the calibrator, make sure to open the cap, and gently tighten it back ensuring no leaks. Do not overtighten the cap, otherwise you may experience needle clogs.
- Invert the tubes for at least 20–30 seconds to mix the calibrator material thoroughly. The red precipitate at the bottom of the tube has to be completely suspended and the red color of the fluid needs to be evenly distributed. Tubes stored for a long time might require longer mixing.
- Gently invert the tube 8–10 times immediately before sampling.
- If the tube has been open for sampling, clean residual material from the cap and tube rim with a lint-free tissue after the sampling. Close the cap tightly.
- Return the tubes to refrigerator (2–8 °C) within 30 minutes of use.

Analyze the Calibrator:

- Prime the instrument once by aspirating calibrator sample. Discard the result.
- Analyze the calibrator according to the calibrator procedure in the Operator's Manual of your instrument.
- Compare the calibration result for each parameter to the target value.
 - If the difference is within the Expected Range, calibration is optional.
 - If not, calibration may be required.

Adjustment and Verification of the Calibration:

- Calibrate the instrument by applying the calibration adjustment procedures described in the Operator's Manual of your instrument.
- Verify the calibration by analyzing the calibrator again and comparing the results with the target range (step 3, "Analyze the Calibrator").
- Confirm calibration by running quality control material.

Results and Expected Values:

Verify that the lot number on the tube matches the lot number on the table of target values.

Target values are determined on well-maintained, properly calibrated instruments using the instrument manufacturer's recommended reagents. Instruments are calibrated with whole blood using values determined by reference methods.

The ranges given on the assay sheet are intended as guidelines for evaluating the calibration of the instrument. It is recommended that each laboratory establishes its own acceptable ranges.

Reference Methods:

- WBC:** A series of 1:500 dilutions is made with calibrated glassware. Counting is performed on a Coulter Counter Z series instrument. All counts are corrected for coincidence.
- RBC:** A series of 1:50,000 dilutions is made with calibrated glassware. Counting is performed on a Coulter Counter Z series instrument. All counts are corrected for coincidence.
- HGB:** Hemoglobin value is determined by spectrophotometric procedure according to CLSI Standard H15-A3 and is traceable to ICSH/WHO International Haemoglobinocyanide Standard.
- HCT:** Packed cell volume (PCV) is measured by the microhematocrit procedure according to CLSI Standard H7-A3. No correction is made for trapped plasma.
- PLT:** A series of 1:126 dilutions is made using calibrated glassware in 1% ammonium oxalate. Platelets are counted using a hemocytometer and phase contrast microscopy.

Limitations of the Procedure:

The performance of this product is assured only if it is properly stored and handled as described in this insert. Incomplete mixing of a tube prior to use invalidates both the sample withdrawn and any remaining material in the tube.

Calibrator vials can be pierced maximum 40 times. After that the rubber part of the cap has the risk of dropping into the calibrator, causing clogs in the instrument.

Text passages with grey background were changed in the latest revision of this package insert.



Bestellinformation:

Katalog-Nr.	Artikelname	Inhalt
HE3611	H3/5-Cal	1 x 2,5 mL

Anwendungszweck:

Der H3/5-Cal ist für die Kalibration von Analyticon Hämatologie-Analysegeräten Hemolyzer® 3 NG (HE3100) und Hemolyzer® 5 NG (closed und open mode) (HE5100 und HE5200) vorgesehen.

Zusammenfassung und Erläuterung:

Hämatologie-Analysegeräte benötigen eine regelmäßige Kalibration, um korrekte Patientenergebnisse zu liefern. Dieser Kalibrator ist ein stabiles Vollblutpräparat, das für die Bestätigung und Anpassung der Kalibration von Analyticon Hämatologie-Analysegeräten Hemolyzer® 3 NG (HE3100) und Hemolyzer® 5 NG (closed und open mode) (HE5100 und HE5200) verwendet werden kann.

Reagenzien:

Der H3/5-Cal setzt sich aus humanen Erythrozyten, und Leukozyten und Blutplättchen aus Säugetieren zusammen, aufgelöst in einer Plasma-ähnlichen Flüssigkeit mit Konservierungsmitteln. Für Lot-spezifische Konzentrationen, beziehen Sie sich bitte auf die Tabelle am Ende des Textes.

Warn- und Vorsichtshinweise:

Nur zum Gebrauch als in vitro Diagnostikum.
Anwendung nur durch geschultes Laborpersonal.



Alle Körperflüssigkeiten sollten als potentiell infektiöses Material betrachtet werden. Das Produkt wurde negativ auf anti-HIV 1 und 2, anti-HCV und HBsAg getestet, doch da keine Testmethode das Risiko einer Infektion mit absoluter Sicherheit ausschließen kann, behandeln Sie alle Blutproben und andere potentiell infektiöse Materialien mit den entsprechenden Vorsichtsmaßnahmen. Verwenden Sie Handschuhe, Atemschutz und Laborkleidung, falls der Kontakt mit Blut zu erwarten ist.

Die beim Umgang mit Laborreagenzien üblichen Vorsichtsmaßnahmen beachten. Bei der Entsorgung des Produktes müssen die jeweiligen gesetzlichen Vorschriften beachtet werden.

Weitere sicherheitsrelevante Informationen sind im Sicherheitsdatenblatt enthalten. Dieses steht auf unserer Homepage <http://www.analyticon-diagnostics.com> zum Download bereit.

Lagerung und Stabilität:

Ungeöffnetes Röhrchen	Bis zum Ende des Haltbarkeitsdatums	2 – 8 °C
Geöffnetes Röhrchen	5 Tage	2 – 8 °C

Lagern Sie die Röhrchen in aufrechter Position. Nicht einfrieren!

Anzeichen von Verfall des Produktes:

Nach dem Mischen sollte das Produkt ein ähnliches Aussehen wie frisches Vollblut aufweisen. In ungemischten Röhrchen kann der Überstand wolkig rötlich erscheinen, was normal und kein Zeichen von Verfall ist. Andere Verfärbungen, ein sehr dunkelroter Überstand oder unerwartete Ergebnisse können Zeichen von Verfall sein. Falls das Ergebnis des Kalibrators außerhalb des erlaubten Bereiches liegt, bei gleichzeitig stabilen Ergebnissen des Kontrollmaterials und der QC vergleichender Labore und/oder die Leistungsprüfung eine exzellente Übereinstimmung innerhalb der Vergleichsgruppen aufweist, könnte das Produkt möglicherweise beschädigt sein.

Verwenden Sie das Produkt nicht, wenn Sie Verfall vermuten.

Vorgehen:

Mischen und Probennahme:

- Geben Sie den Röhrchen mindestens 15 Minuten Zeit, um Raumtemperatur (15 bis 30 °C) zu erreichen.
- Achten Sie darauf, dass die Kappe des Kalibrators vor dem ersten Gebrauch geöffnet und vorsichtig wieder angezogen wird, um Undichtigkeiten zu vermeiden. Ziehen Sie die Kappe nicht zu fest an, da es sonst zu Verstopfungen der Nadel kommen kann.
- Invertieren Sie die Röhrchen für mindestens 20–30 Sekunden, um das Kalibrationsmaterial gründlich durchzumischen. Der rote Niederschlag auf dem Boden der Röhrchen muss vollständig aufgelöst und die rote Farbe der Flüssigkeit gleichmäßig verteilt sein. Röhrchen, die für längere Zeit gelagert wurden, bedürfen eventuell längerem Mischen.
- Invertieren Sie die Röhrchen kurz vor der Probennahme noch 8–10 Mal.
- Falls das Röhrchen während der Probenentnahme geöffnet worden ist, reinigen Sie die Kappe und den Rand des Röhrchens mit einem fusselfreien Tuch, bevor Sie es wieder fest verschließen.
- Stellen Sie die Röhrchen innerhalb von 30 Minuten wieder kühl (2–8 °C).

Messung des Kalibrators:

- Führen Sie eine Messung des Kalibrators durch, um das Gerät zu primen. Verwerfen Sie die Ergebnisse.
- Messen Sie den Kalibrator gemäß den Anleitungen in dem Benutzerhandbuch Ihres Instruments.
- Vergleichen Sie die Ergebnisse jedes Parameters mit den Zielwerten.
 - Falls die Messergebnisse des Kalibrators innerhalb der erlaubten Bereiche liegen, ist eine Kalibration optional.
 - Falls nicht, ist eine Kalibration eventuell notwendig.

Anpassung und Verifizierung der Kalibration:

- Kalibrieren Sie das Instrument mittels der Anpassungsprozeduren der Kalibration in Ihrem Benutzerhandbuch.
- Überprüfen Sie die Kalibration, indem Sie den Kalibrator erneut messen und die Messergebnisse mit dem erlaubten Bereich vergleichen (Schritt 3, „Messung des Kalibrators“).
- Verifizieren Sie die Kalibration mit Qualitätskontrollmessungen.

Ergebnisse und Zielwerte:

Stellen Sie sicher, dass die Lot Nummern auf den Röhrchen und der Tabelle mit Zielwerten übereinstimmen.

Die Zielwerte wurden auf gut gewarteten, sorgfältig kalibrierten Analysegeräten mit den vom Hersteller empfohlenen Reagenzien bestimmt. Die Geräte sind mit Vollblut kalibriert worden, dessen Werte mit den unten genannten Referenzmethoden bestimmt worden sind.

Die erlaubten Bereiche auf dem Sollwertzettel sind als Richtwerte für die Evaluierung der Kalibration Ihres Instrumentes vorgesehen. Es wird empfohlen, dass jedes Labor seine eigenen erlaubten Bereiche bestimmt.

Referenzmethoden:

- WBC:** Eine Reihe von 1:500 Verdünnungen wurde mit geeichten Glasinstrumenten erstellt. Zellzahlen wurden an einem Coulter Counter der Z Serie ermittelt. Alle Zellzahlen wurden mit der Messunsicherheit korrigiert.
- RBC:** Eine Reihe von 1:50.000 Verdünnungen wurde mit geeichten Glasinstrumenten erstellt. Zellzahlen wurden an einem Coulter Counter der Z Serie ermittelt. Alle Zellzahlen wurden mit der Messunsicherheit korrigiert.
- HGB:** Hämoglobin wurde mittels der spektrophotometrischen Methode gemäß des CLSI Standard H15-A3 bestimmt, und ist zurückverfolgbar auf den ICSH/WHO International Haemoglobincyanide Standard.
- HCT:** Das anteilige Zellvolumen (PVC) wurde mit der Mikrohämatokritmethode gemäß CLSI Standard H7-A3 ermittelt. Es wurde keine Korrektur für eingeschlossenes Plasma durchgeführt.
- PLT:** Eine Reihe von 1:126 Verdünnungen wurde mit geeichten Glasinstrumenten in 1%igem Ammoniumoxalat erstellt. Blutplättchen wurden mittels eines Hämozytometers und mittels Phasenkontrastmikroskopie bestimmt.

Einschränkungen der Anwendung:

Die Leistung dieses Produktes ist bei ordnungsgemäßer Lagerung und Handhabung sichergestellt. Ungenügendes Mischen vor der Verwendung macht die eingesetzte Probe und das verbliebene Material im Probenröhrchen unbrauchbar.

Der Gummiteil der Kappe des Kalibratorröhrchens kann maximal 40 Mal durchstochen werden. Danach besteht die Gefahr, dass Gummiteile der Kappe in den Kalibrator fallen und im Anschluss das Gerät verstopfen.

Grau hinterlegte Textpassagen wurden in der letzten Überarbeitung dieser Gebrauchsanweisung geändert.



H3/5-Cal

Hemolyzer® NG Calibrator



Información del pedido:

No. de Catálogo	Nombre del artículo	Contenido
HE3611	H3/5-Cal	1 x 2,5 mL

Uso previsto:

H3/5-Cal está diseñado para la calibración de los analizadores hematológicos Analyticon Hemolyzer® 3 NG (HE3100) y Hemolyzer® 5 NG (modo cerrado y abierto) (HE5100 y HE5200).

Resumen y explicación:

Los analizadores hematológicos requieren una calibración periódica para generar resultados precisos del paciente. Este calibrador es una preparación de sangre completa y estable que se puede usar para verificar y ajustar la calibración de determinados instrumentos de hematología.

Reactivos:

El H3/5-Cal está compuesto de eritrocitos humanos, leucocitos de mamíferos y plaquetas de mamífero suspendidas en un líquido similar al plasma con conservantes. Para conocer las concentraciones específicas del lote, consulte la tabla a continuación.

Advertencias y precauciones:

Solamente para uso en diagnóstico in vitro.

Sólo para uso del profesional de laboratorio capacitado.



Todas las muestras de fluidos corporales deben considerarse materiales potencialmente infecciosos. El producto dio negativo contra el VIH 1 y 2, el VHC y el HBsAg, pero como ningún método de prueba puede descartar el peligro de infección con absoluta certeza, trate toda la sangre y otros materiales potencialmente infecciosos con las precauciones adecuadas. Use guantes, máscaras y batas si se prevé la exposición a la sangre.

Siga las precauciones habituales requeridas al manipular todos los reactivos de laboratorio. La eliminación del producto debe realizarse de acuerdo con las normativas locales.

La ficha de datos de seguridad de materia contiene mayor información relacionada a la seguridad. Disponible en nuestro sitio <http://www.analyticon-diagnostics.com>.

Almacenamiento y estabilidad:

Envase sin abrir	Hasta la fecha de vencimiento	2 – 8 °C
Envase abierto	5 días	2 – 8 °C

Guarde los tubos en posición vertical. ¡No congelar!

Indicaciones de deterioro:

Después de mezclar, el producto debe tener un aspecto similar al de la sangre entera fresca. En viales no mezclados, el sobrenadante puede aparecer turbio y rojizo; esto es normal y no indica deterioro. Otra decoloración, un sobrenadante de color rojo muy oscuro o resultados inaceptables pueden indicar deterioro.

Si el resultado del calibrador está fuera del rango encontrado en la hoja de ensayo, mientras que los resultados del control y el control de calidad interlaboratorios son estables, y/o los informes de las Pruebas de Aptitud tienen un excelente acuerdo de grupo de pares, esto puede indicar posibles daños al producto.

No utilice el producto si sospecha que está deteriorado.

Procedimiento:

Mezcla y muestreo:

- Dejar que los tubos alcancen la temperatura ambiente (de 15 a 30 ° C) durante al menos 15 minutos.
- Asegúrese de abrir la tapa del tubo del calibrador antes del primer uso y vuelva a apretarla suavemente para evitar fugas. No apriete demasiado la tapa, ya que esto podría bloquear la aguja.
- Invierta los tubos durante al menos 20-30 segundos para mezclar bien el material del calibrador. El precipitado rojo en el fondo del tubo tiene que estar completamente suspendido y el color rojo del fluido tiene que ser distribuido uniformemente. Los tubos almacenados durante mucho tiempo pueden requerir una mezcla más larga.
- Invierta suavemente el tubo de 8 a 10 veces inmediatamente antes del muestreo.
- Si el tubo ha sido abierto para el muestreo, limpie el material residual de la tapa y el borde del tubo con un pañuelo sin pelusa después del muestreo. Cierre bien la tapa.
- Regrese los tubos al refrigerador (2–8 ° C) dentro de los 30 minutos de uso.

Analice el calibrador:

- Bebe el instrumento una vez aspirando la muestra del calibrador. Descarte el resultado.
- Analice el calibrador de acuerdo con el procedimiento de calibración del Manual del Operador de su instrumento.
- Compare el resultado de la calibración de cada parámetro con el valor debido.
 - Si la diferencia está dentro del rango esperado, la calibración es opcional.
 - Si no es así, puede ser necesaria la calibración.

Ajuste y verificación de la calibración:

- Calibre el instrumento aplicando los procedimientos de ajuste de calibración descritos en el Manual del Operador de su instrumento.
- Verifique la calibración analizando de nuevo el calibrador y comparando los resultados con el rango objetivo (paso 3, "Analizar el calibrador").
- Confirme la calibración ejecutando el material de control de calidad.

Resultados y valores esperados:

Verifique que el número de lote en el tubo coincida con el número de lote en la tabla de valores objetivo.

Los valores objetivo se determinan en instrumentos bien mantenidos y debidamente calibrados utilizando los reactivos recomendados por el fabricante del instrumento. Los instrumentos se calibran con sangre entera utilizando valores determinados por métodos de referencia.

Los rangos que aparecen en la hoja de ensayo sirven de guía para evaluar la calibración del instrumento. Se recomienda que cada laboratorio establezca sus propios rangos aceptables.

Métodos de referencia:

- WBC:** Una serie de diluciones de 1:500 se realiza con cristalería calibrada. El conteo se realiza en un instrumento de la serie Coulter Counter Z. Todos los conteos se corrigen por coincidencia.
- RBC:** Una serie de diluciones de 1:50.000 se realiza con cristalería calibrada. El conteo se realiza en un instrumento de la serie Coulter Counter Z. Todos los conteos se corrigen por coincidencia.
- HGB:** El valor de hemoglobina se determina mediante un procedimiento espectrofotométrico de acuerdo con la norma CLSI H15-A3 y es trazable a la norma internacional de hemoglobina IC5H/OMS.
- HCT:** El volumen de las células envasadas (PCV) se mide mediante el procedimiento de microhematocrito de acuerdo con la norma CLSI H7-A3. No se hace ninguna corrección para el plasma atrapado.
- PLT:** Una serie de diluciones de 1:126 se realiza utilizando cristalería calibrada en oxalato de amonio al 1%. Las plaquetas se cuentan utilizando un hemocytómetro y un microscopio de contraste de fase.

Limitaciones del procedimiento:

El rendimiento de este producto sólo está garantizado si se almacena y manipula correctamente tal y como se describe en este prospecto. La mezcla incompleta de un tubo antes de su uso invalida tanto la muestra extraída como cualquier material remanente en el tubo.

La parte de goma de la tapa del tubo del calibrador puede perforarse un máximo de 40 veces. Después de esto existe el riesgo de que las partes de goma de la tapa caigan en el calibrador pudiendo obstruir posteriormente el dispositivo.

Los pasajes de texto con fondo gris se cambiaron en la última revisión de este prospecto.



Информация для заказа :

№. по каталогу	Название изделия	Содержание
HE3611	H3/5-Cal	1 x 2,5 мл

Предназначенное использование:

H3/5-Cal предназначен для калибровки гематологических анализаторов компании «Analyticon» Hemolyzer® 3 NG (HE3100) и Hemolyzer® 5 NG (закрытый и открытый режим) (HE5100 и HE5200).

Краткое описание и разъяснение:

Гематологические анализаторы требуют периодической калибровки для получения точных результатов пациента. Этот калибратор является стабильным препаратом цельной крови, который можно использовать для проверки и регулирования калибровки некоторых гематологических приборов

Реагенты:

H3/5-Cal состоит из эритроцитов человека, лейкоцитов млекопитающих и тромбоцитов млекопитающих, суспендированных в сходной с плазмой жидкости с консервантами. Для конкретных концентраций лотов, пожалуйста, обратитесь к таблице ниже.

Предупреждение и меры предосторожности:

Только для диагностики in vitro.

Только для обученных лабораторных специалистов.



Все образцы жидкостей организма должны рассматриваться как потенциально инфекционные материалы. Были получены отрицательные результаты в испытаниях продукта в отношении анти- HIV 1 и 2, анти- HCV и HBsAg, но, поскольку ни один метод тестирования не может исключить опасность инфекции с абсолютной уверенностью, обрабатывайте всю кровь и другие потенциально инфекционные материалы с соответствующими мерами предосторожности. Используйте перчатки, маски и халаты, если предполагается возможное попадание крови.

Соблюдайте обычные меры предосторожности, необходимые для работы со всеми лабораторными реагентами. Утилизация продукта должна осуществляться в соответствии с местными правилами.

Паспорт безопасности материала содержит дополнительную информацию, касающуюся безопасности. Ее можно загрузить с нашей домашней страницы <http://www.analyticon-diagnostics.com>.

Хранение и стабильность:

Неоткрытая пробирка	до истечения срока годности	2 - 8 ° C
Открытая пробирка	5 дней	2 - 8 ° C

Хранить пробирки в вертикальном положении. Не замораживать!

Признаки повреждения продукта :

После смешивания продукт должен быть внешне похож на свежую цельную кровь. В несмешанных флаконах супернатант может выглядеть мутным и красноватым, что является нормальным и не указывает на повреждение. Другие изменения цвета, очень темно- красный супернатант или неприемлемые результаты могут указывать на повреждение.

Если результат калибровки находится за пределами диапазона, указанного в листе анализа, тогда как результаты контроля и межлабораторный контроль качества являются стабильными, и/или отчеты о квалификационных тестированиях имеют превосходное сходство с аналогами, это может указывать на возможное повреждение продукта.

Не используйте продукт, если есть подозрение на его повреждение.

Процедура:**Смешивание и отбор образцов:**

1. Дайте пробиркам согреться до комнатной температуры (от 15 до 30 ° C) в течение не менее 15 минут.
2. Перед первым использованием калибратора убедитесь в том, что крышка открыта, и аккуратно затяните ее обратно, гарантируя отсутствие утечек. Не затягивайте чрезмерно крышку, иначе могут возникнуть засорение иглы.
3. Переворачивайте пробирки в течение не менее 20–30 секунд, чтобы полностью перемешать материал калибратора. Красный осадок на дне пробирки должен быть полностью растворён, а красный цвет жидкости должен быть равномерно распределен. Пробирки, хранящиеся в течение длительного времени, могут потребовать более длительного перемешивания.
4. Осторожно переверните пробирку 8–10 раз непосредственно перед отбором образцов.
5. Если пробирка была открыта для отбора образцов, то после отбора образцов удалите остатки материала с крышки и края пробирки безворсовой тканью. Закройте плотно крышку.
6. Верните пробирки в холодильник (2–8° C) в течение 30 минут после использования.

Проанализируйте калибратор:

1. Заполните прибор один раз всасыванием образца калибратора. Сбросьте результат.
2. Проанализируйте калибратор в соответствии с процедурой калибровки, приведенной в руководстве по эксплуатации вашего прибора.
3. Сравните результат калибровки для каждого параметра с заданным значением.
 - a) Если разница находится в пределах ожидаемого диапазона, то калибровка не является обязательной.
 - b) В противном случае может потребоваться калибровка.

Регулировка и проверка калибровки:

1. Откалибруйте прибор, применяя процедуры регулирования калибровки, описанные в руководстве по эксплуатации вашего прибора.
2. Проверьте калибровку, повторно проанализировав калибратор и сравнив результаты с заданным диапазоном (шаг 3, «Проанализируйте калибратор»).
3. Подтвердите калибровку прогоном материала контроля качества.

Результаты и ожидаемые значения:

Убедитесь, что номер лота на пробирке соответствует номеру лота в таблице заданных значений.

Заданные значения определяются на приборах в хорошем состоянии с правильным техническим обслуживанием и правильно откалиброванных с использованием рекомендованных производителем реагентов. Приборы калибруются с использованием цельной крови, при помощи значений, определенных эталонными методами.

Диапазоны, указанные в аналитическом листе, предназначены для оценки калибровки прибора. Рекомендуется, чтобы каждая лаборатория установила свои собственные приемлемые диапазоны.

Эталонные методы:

1. **WBC (лейкоциты):** серия разбавлений 1:500 производится с градуированной стеклянной тарой. Подсчет производится на приборе Coulter Counter серии Z. Все подсчеты скорректированы на совпадение.
2. **RBC (эритроциты):** серия разбавлений 1:50.000 производится с градуированной стеклянной тарой. Подсчет производится на приборе CoulterCounter серии Z. Все подсчеты скорректированы на совпадение.
3. **HGB (гемоглобин):** значение гемоглобина определяется спектрофотометрической процедурой в соответствии со стандартом CLSI H15-A3 и отслеживается по международному гемоглобинцианидному стандарту ICSH/WHO.
4. **HCT (гематокрит):** объём осадённых эритроцитов (PCV) измеряют с помощью микрогематокритной процедуры в соответствии со стандартом CLSIH7-A3. Коррекция на захваченную плазму не производится.
5. **PLT (тромбоциты):** серия разбавлений 1:126 производится с использованием градуированной стеклянной тары в 1% оксалате аммония. Тромбоциты подсчитывают с использованием гемоцитометра и фазово-контрастной микроскопии.

Ограничения процедуры:

Характеристики этого продукта гарантируются, только если он правильно хранится и обрабатывается, как описано в этом вкладыше. Неполное размешивание пробирки перед использованием делает непригодным для использования как отобранный образец, так и любой остаточный материал в пробирке.

Резиновую часть колпачка флакона калибратора можно проколоть максимум 40 раз. После этого резиновая часть колпачка может упасть в калибратор, что вызовет засорение прибора.

Текст, выделенный серым цветом, был изменен в последней редакции данного руководства.



Hemolyzer® 3 NG Reagent Pack

▶ Product Information ◀

Product name	Product code	Number of tests
H3-Compact 100	HE3701	100
H3-Compact 500	HE3705	500

▶ Product Content ◀

	H3-Compact 100	H3-Compact 500
Diluent	1100 mL	3550 mL
Lyse	350 mL	750 mL
Cleaner	400 mL	1150 mL
Instructions for use	1 pc	1 pc
QR Code	1 pc	1 pc

▶ Intended Use and Test Principle ◀

H3-Compact 100 and H3-Compact 500 are dedicated set of reagents intended to be used with Hemolyzer® 3 NG semi-automated hematology analyzers. The reagent pack contains the following reagents: Diluent, Lyse and Cleaner.

Diluent reagent is a buffered, stabilized, and micro-filtered electrolyte solution for automated dilution of human blood samples, quantitative and qualitative determination of red blood cells (RBC), white blood cells (WBC), white blood cells subpopulations (lymphocytes [LYM], mid-size cells [MID], granulocytes [GRA]), platelets (PLT) and measurement of hemoglobin (HGB) concentration.

Lyse reagent is a stabilized and micro-filtered lysing agent for stromatolysis of red blood cells (RBC), for quantitative determination of white blood cells (WBC), for WBC 3-part differentiation (lymphocytes [LYM], mid-size cells [MID], granulocytes [GRA]) and hemoglobin (HGB) concentration measurement of human blood.

Cleaner reagent is a buffered, stabilized, and micro-filtered electrolyte solution used for conditioning and cleaning of specific tubing sections and chambers.

The reagent is intended for laboratory professional use as an in vitro diagnostic medical device.

▶ Reagent Preparation ◀

The product is ready to use, please follow the installation procedures of this instructions for use.

▶ Warnings and Precautions ◀

- Read instructions for use carefully before use.
- The product is environmentally friendly, azide-free, and does not contain harmful ingredients. This product is classified as non-hazardous in compliance with Regulation (EC) No 1272/2008.
- Do not use the product beyond the expiry date.
- Do not use the product if the primary package is damaged or there is visible sign of chemical deterioration of the liquid inside. In both cases the product should be replaced.
- Store at the recommended temperature range.
- Do not use the product if it has been frozen or kept at excessive heat. Use the product at room temperature (18-30°C). If it has been stored below 18°C or above 30°C, leave it at normal room temperature for 3 hours before use.
- Users are advised to wear approved protective clothing when handling chemical products: lab coat, gloves, and eye protection.
- Observe standard laboratory precautions for use and follow national or local health and safety guidelines.
- Avoid contact with eyes, skin, and clothing. In case of contact with eyes or skin, rinse immediately with plenty of water.
- Please refer to the product's Safety Data Sheet.
- Please report any serious incident involving the product to the manufacturer and the competent local authority.

▶ Product Composition ◀

	Diluent	Lyse	Cleaner
Sodium chloride	< 1.5 %	-	< 1.5 %
Surfactants	-	< 3.5 %	-
Buffers	< 1.0 %	< 1.0 %	< 1.0 %
Stabilizers	< 0.5 %	< 0.5 %	< 0.5 %
Preservatives	< 0.5 %	< 0.5 %	< 0.5 %
Ion-free water	> 96.5 %	> 94.5 %	> 96.5 %

▶ Storage and Shelf Life ◀

- Storage conditions: **2-35°C**.
- Shelf life: **4 years**.
- Open bottle stability: **6 months**.
- Expiry date: **refer to the product's labeling**.

▶ Waste Management ◀

Dispose waste product, unused product, and contaminated packaging in compliance with local regulations.

► Materials Required but not Provided ◄

- Hemolyzer® 3 NG hematology analyzer.
- Reagent pickup tubes and caps.
- Empty waste container.
- Control and calibrator materials.

► Reagent Installation Precautions ◄

- Person installing the reagent must be trained laboratory professional.
- Always keep the reagent in its original container.
- Do not mix the remains of a reagent with another container.
- Use the reagent pickup tubes and caps supplied with the instrument or remove them from the old reagent.
- Clean the pickup tubes by wiping them from top to bottom, using lint-free tissue dampened with distilled water. Avoid any dust or microbial contamination of the tubing and reagent.
- Do NOT place the product above the instrument or on the ground! Place it on the same level as the analyzer.

► Connecting the Reagent ◄

1. Open the caps of the bottles inside the reagent pack. Cut the sealing foil using a clean, sharp object and carefully remove it from the bottles. 
2. Immerse the pickup tube into the reagent and tighten the cap. Make sure you match the color on the tube, the cap, and the back of the analyzer with the correct reagent:
 - Diluent – **GREEN**
 - Lyse – **YELLOW**
 - Cleaner – **WHITE**

Make sure the pickup tubes are not bent, broken, twisted, or blocked.

3. Connect an empty waste container with RED cap. Waste container should be placed on the ground.
4. Turn on the analyzer and wait for the startup process to finish. Tap and hold any point on the screen to access the local menu.
5. Tap the “Read QR” icon. Hold the QR code approximately 10 - 15 centimeters from the QR/barcode reader or camera.  Ensure the QR sheet is not curved or bent. In case the sheet is damaged, use manual data entry.
6. When the QR code data is entered, the product is ready to use.
7. Run a Fast Blank measurement.











► Reagent Replacement ◄

1. Turn on the analyzer and wait for the startup process to finish. Tap and hold any point on the screen to access the local menu.
2. Tap the “Reag. Replace” icon. Follow the steps on the screen, tap “Next” when a step is complete.
3. The sequence will end with an automated priming cycle and a Fast Blank measurement. When the Fast Blank is in range, the analyzer will display the result and you can use the new reagent.
4. When a new reagent batch is used, verify performance with control measurements and perform calibration if needed.

► Limitations ◄

- The reagent pack is designed to run the number of tests mentioned in the "Product Information" section under the following conditions:
 - A minimum # of tests are measured daily:
 - **H3-Compact 100: 3-5 samples per day.**
 - **H3-Compact 500: 15 samples per day.**
 - Two Fast Blanks are performed daily.
 - The analyzer is powered off every day.
 - The necessary maintenance actions prompted by the software are performed.
- After the specified number of tests, no new samples can be measured.
- The amount of leftover reagent inside the pack may vary depending on usage.
- Quality control, calibration and patient samples equally reduce the number of tests available.
- Running lower number of daily tests or more Fast Blank measurements than the conditions listed above will result in relatively more reagent consumption and the pack can run out of reagents before the specified number of tests.
- No complaints are accepted regarding leftover reagents or about the number of tests, if the above listed conditions are not met.

► Explanation of Symbols ◄

	Catalogue number		Batch number
	Expiry date		In vitro diagnostic medical device
	Permitted storage temperature		CE mark
	See the instructions for use		Manufacturer
	Content		Date of manufacture
	Distributor		