

THE NETHERLANDS
(N E D E R L A N D)

COMMUNICATION

Concerning ⁽¹⁾

- ~~approval granted~~
- approval extended
- ~~approval refusal~~
- ~~approval withdrawn~~
- ~~production definitely discontinued~~

of a type of tyre for motor vehicles pursuant to Regulation number 30.

Approval number: E4*30R02/21*97201*04

1. Manufacturer's name and address : ZODO TIRE Co., LIMITED
The South of Yalujiang Road, Wenzhuang Village Qinghe Agency of
Cao County Heze City
Shandong Province 274400
China(PRC)
2. Tyre type designation⁽²⁾
 - 2.1. Brand-name(s)/trademark(s) : See annex 1 of communication form
 - 2.2. Trade description(s)/Commercial name(s) : See annex 1 of communication form
3. If applicable, name and address of the manufacturer's representative : Not applicable
4. Summarised description
 - 4.1. Tyre size designation : 185/65R14
 - 4.2. Category of use : ~~normal~~/snow/~~special use~~ / ~~temporary use~~ ⁽¹⁾
 - 4.3. Structure : ~~diagonal~~ / ~~bias belted~~/radial/ ~~run flat tyre~~ ⁽¹⁾
 - 4.4. Speed category symbol : H
 - 4.5. Load-capacity index : 86

Approval number: E4*30R02/21*97201*04

- 4.6. Extended Mobility Tyre : ~~Yes~~ /No⁽¹⁾
5. Technical service and, where applicable, test laboratory approved for purposes of approval or of verification of conformity : IDIADA Automotive Technology S.A. Institute for Applied Automotive Research
L' Albornar P.O. Box 20
E-43710 Santa Oliva (Tarragona)
Spain
6. Date of report issued by that service : 2016-09-17; 2020-02-26
7. Number of report issued by that service : extension number 00; CN20020373
8. Reason(s) of extension (if applicable) : Update of tyre type designation(s)
Upgrade of regulation supplement number
Update of construction variant(s)
Type approval number is converted in accordance to the layout of revision 3 of the 1958 agreement.
Addition of brand names; Addition of trade descriptions; Modification of manufacturer's name
Change of technical service
9. Any remarks : Not applicable
10. Place : Zoetermeer
11. Date : 24 March 2020
12. Signature :

P. Lingsma

13. The list of documents in the approval file which are deposited at the administrative service having delivered the approval and which can be obtained upon request.
- Application form relating to ECE approval for a pneumatic tyre pursuant to Regulation number 30.
 - The drawing of the tyre's sidewalls, tread and dimensioned cross-section.
 - The test report as mentioned in item 7.

⁽¹⁾ Strike out what does not apply

⁽²⁾ A list of Brand name(s)/trademark(s) or Trade description(s)/Commercial name(s) may be annexed to this communication

Approval number: E4*30R02/21*97201*04

Annex 1

2. Tyre type designation

2.1. Brand-name(s)/trademark(s):

CONSTANCY; ILINK; LUXXAN; RHINO; ARIVO; GRENLANDER; T TYRE; CRYSTAL; ROCKBLADE; FRONWAY; SAILWIN; XBRI; ROADMARCH; KANGS; ZMAX

2.2. Trade description(s)/Commercial name(s):

COLO H01; L-GRIP66; LY168; ECOGREEN 66; VENUSATR 66; Energize; PREMIO ARZ1; ECOLOGY; INSPIRER C4; THREE; ROCK 515; PRIMESTAR 66; ENRI U08; EURUS 08; LY169; THUNDER U09; FOUR; VENUSATR 08; ULTRA ARZ4; SPORT+2; INSPIRER S8; ROCK 525; PRIME UHP 08; Envoy; Winter GL868; Winter IL868; LY868; ICEPOWER 868; ICEWINNER 868; WINMASTER ARW2; ROCK 868S; THIRTY TWO; SNOWROVER 868; COMMANDER W7; GREENWING A/S; MULTIMATCH A/S; FRONWING A/S; FREIMATCH A/S; Carlorful A/S; PRIME A/S; ROCK A/S ONE; FORTY ONE; INSPIRER A/S 1; COLO H02; L-GRIP55; ECOGREEN 55; VENUSATR 55; PREMIO ARZERO; INSPIRER ECO; ROCK 555; PRIMESTAR 55; LANDGEMA; LY566; SPORTWAY 56; SPEEDWAY 56; L-ZEAL56; EMOTION; TEN; ULTRA ARZ5; SPORT+; INSPIRER S4; Drift; ROCK 566; MAHO 77; POWERCITY 77; TOPOWER 87 H/T; ROADPOWER H/T; ROADKING H/T; TERRANO ARV H/T; FORZA H/T 2; INSPIRER F4; ROCK 717 H/T; TWENTY TWO; Maxim; PRIMEMARCH H/T 77; MAGA A/T ONE; FORZA A/T; TERRAMAX LSR1 A/T; TERRA XPLOER C1 A/T; GLADIATAX A/T I; ROCKBLADE A/T I; TERRAMAX ARV A/T; INSPIRER A/T I; TOUGH TRAC A/T I; ROCK 727 A/T; PRIMEMAX A/T I; MAGA A/T TWO; FORZA A/T 2; TERRAMAX LSR2 A/T; TERRA XPLOER C2 A/T; GLADIATAX A/T II; ROCKBLADE A/T II; TERRAMAX ARV PRO A/T; INSPIRER A/T II; TOUGH TRAC A/T II; ROCK 737 A/T; PRIMEMAX A/T II; CAPACITY; ECOPRO 99; COLO H03; L-GRIP99; ECOGREEN 99; VENUSATR99; INSPIRER C9; ROCK 999; LANDGEMA II



APPENDIX 1. CONSTRUCTION IMAGE (1)

ATTACHMENT 20191210

TIRE SIZE 185/65R14 86H

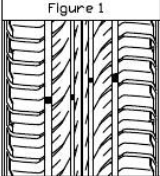
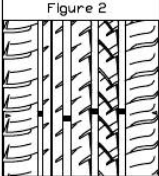
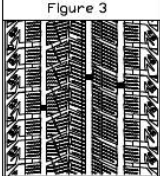
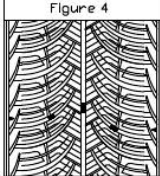
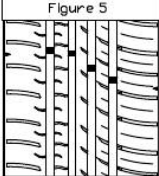
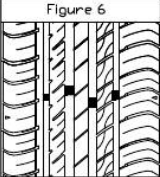
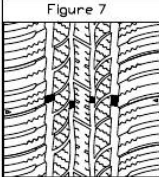
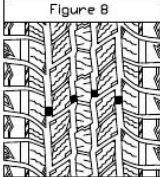
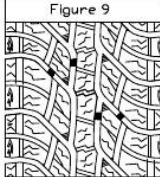
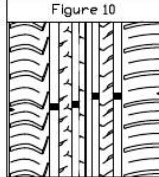
<p>Figure 1</p>  <p>COLO_H01L-GRP96;LY166; ECCOREN 66;VENUSATR 66; Energi+;PREMO AR21;ECOLOGY; INSPIRER CA THREE;ROCK 515; PRIMSTAR 66;</p>	<p>Figure 2</p>  <p>ENR1 U08;EURUS 08;LY166; THUNDER U09;T09; VENUSATR 08;ULTRA AR24; SPORT+2;INSPIRER 58; ROCK 525;PRIME UHF 08 Envoy;</p>	<p>Figure 3</p>  <p>Viper+ GL868/Viper+ L.868; LY868/ICEPOWER 868; ICEVENNER 868/VIPMASTER ARV2; ROCK 868;THIRTY TWO; SNOWROVER 868;COMMANDER V.T.I.</p>	<p>Figure 4</p>  <p>GREENING A/S; MULTIMATCH A/S; FRONWING A/S;FRIMATCH A/S; Colorful A/S;PRIME A/S; ROCK A/S ONE,FORTY ONE; INSPIRER A/S 1;</p>	<p>Figure 5</p>  <p>COLO_H02L-GR955; ECCOREN 55;VENUSATR 55; PREMO ARKERG;INSPIRER ECO; ROCK 555;PRIMSTAR 55; LANDGEMA.</p>
<p>Figure 6</p>  <p>LY566;SPORTWAY 56; SPEEDWAY 56; L-ZEAL56;EMOTION;TEN; ULTRA AR25; SPORT+;INSPIRER 54; DRIF;ROCK 566</p>	<p>Figure 7</p>  <p>MAHO 77;POWEROTY 77; TOPOWER 87 H/T;ROADPOWER H/T; ROADING H/T;TERRANO ARV H/T; FORZA H/T 2;INSPIRER F4; ROCK 737 H/T;TWENTY TWO; Mehm;PRIMMARCH H/T 77;</p>	<p>Figure 8</p>  <p>MAGA A/T ONE;FORZA A/T; TERRAMAX LRH A/T; TERRA SPURON CI A/T; GLADIATOR A/T 1; ROCKBLADE A/T 1; TERRAMAX ARV A/T; INSPIRER A/T 1; TOUGH TRAC A/T 1; ROCK 737 A/T 1; PRIMEAAX A/T 1</p>	<p>Figure 9</p>  <p>MAGA A/T TWO; FORZA A/T 2; TERRAMAX LR2 A/T; TERRA SPURON CI A/T; GLADIATOR A/T 1; ROCKBLADE A/T 1; TERRAMAX ARV PRO A/T; INSPIRER A/T 1; TOUGH TRAC A/T 1; ROCK 737 A/T 1; PRIMEAAX A/T 1;CAPADIZ.</p>	<p>Figure 10</p>  <p>COLO_H02L-GR959; ECCOREN 99;VENUSATR99; INSPIRER 99...ROCK 999; ECCOREN 99;LANDGEMA 11.</p>

6 TREAD WEAR INDICATORS EQUALLY SPACED

DRAWN BY	Xu HuiLi	CHECKED BY	Xie Baoshan	APPROVED BY	Shen Maoqiao	ZDDO TIRE CO.,LIMITED
----------	----------	------------	-------------	-------------	--------------	-----------------------

Page 6 of 6

(1) The tyre marking statements are considered leading in case of deviating drawing information.



APPENDIX 2. CONSTRUCTION IMAGE (1)

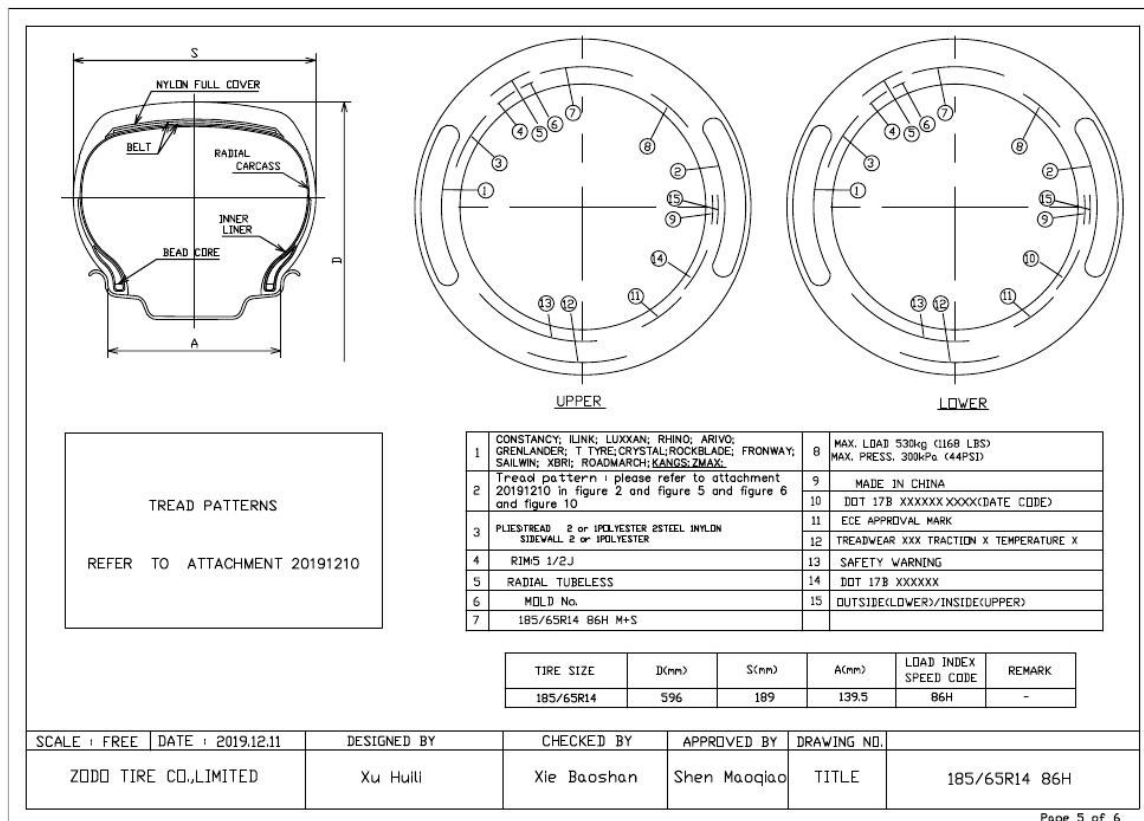

(1) The tyre marking statements are considered leading in case of deviating drawing information.



APPENDIX 3. CONSTRUCTION IMAGE (1)

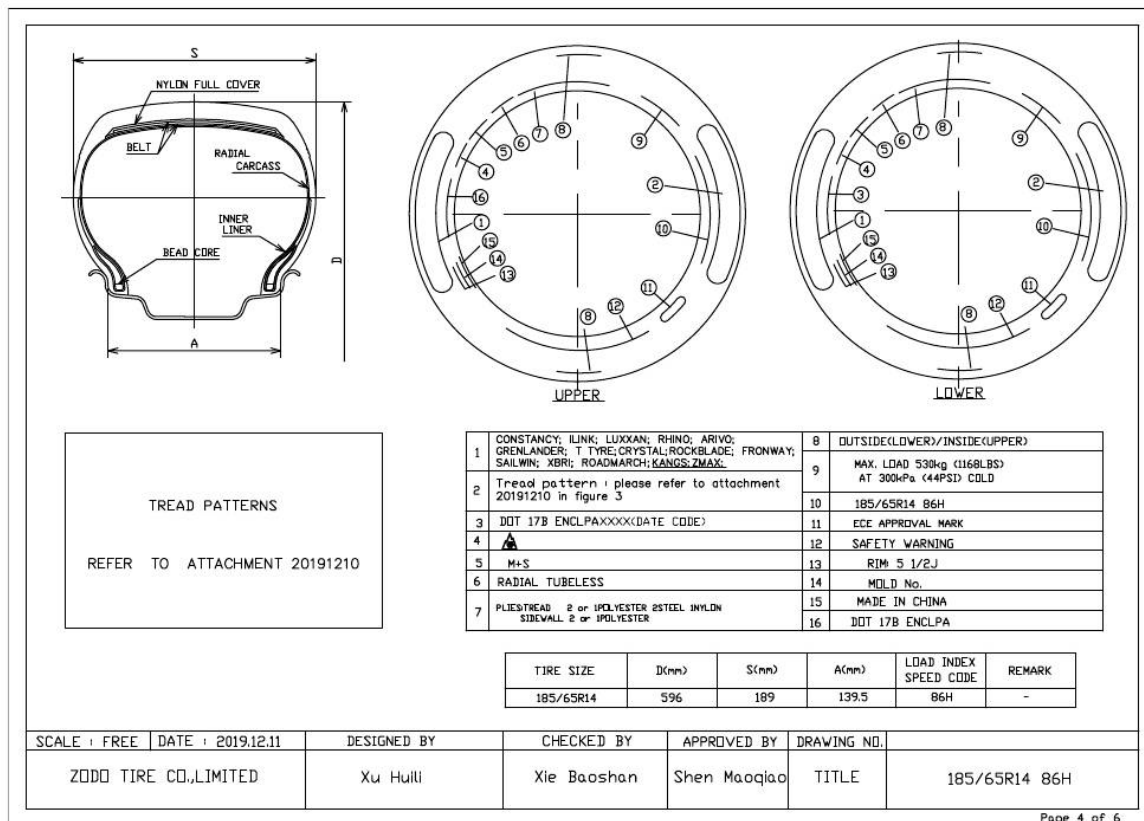

(1) The tyre marking statements are considered leading in case of deviating drawing information.



APPENDIX 4. CONSTRUCTION IMAGE (1)

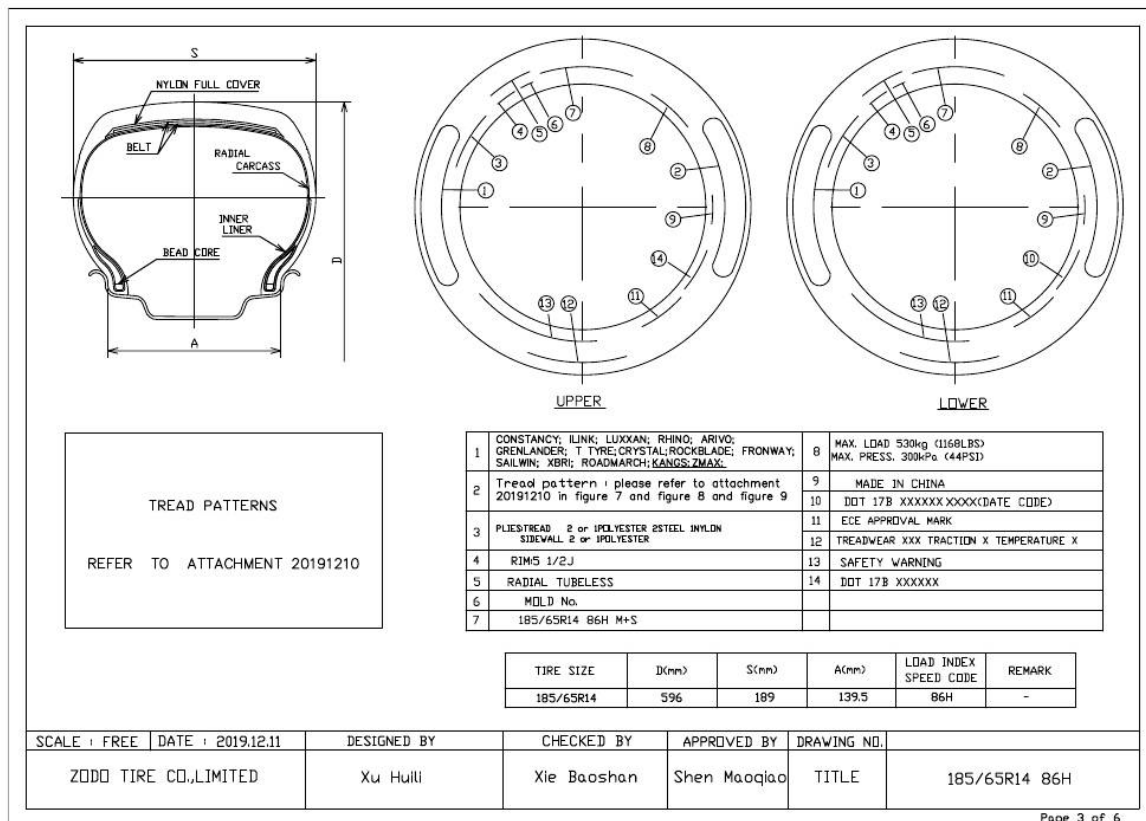

(1) The tyre marking statements are considered leading in case of deviating drawing information.



APPENDIX 5. CONSTRUCTION IMAGE (1)

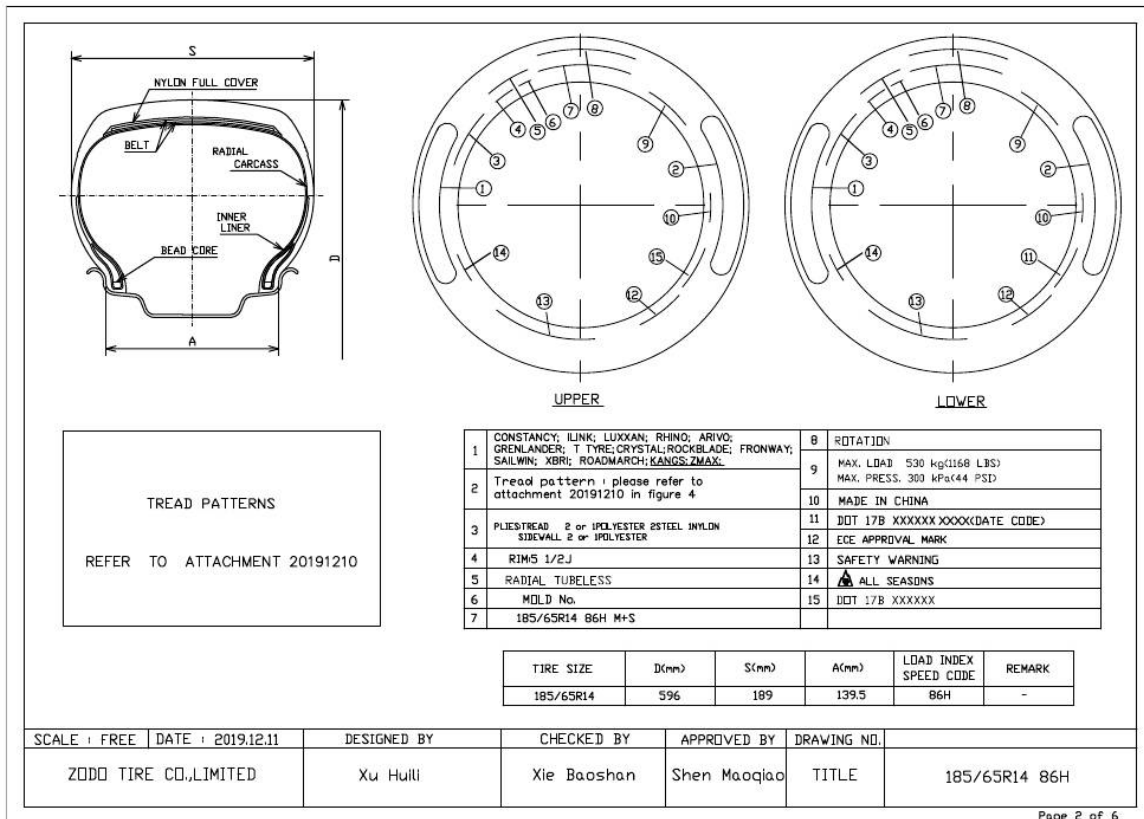

(1) The tyre marking statements are considered leading in case of deviating drawing information.



APPENDIX 6. CONSTRUCTION IMAGE (1)

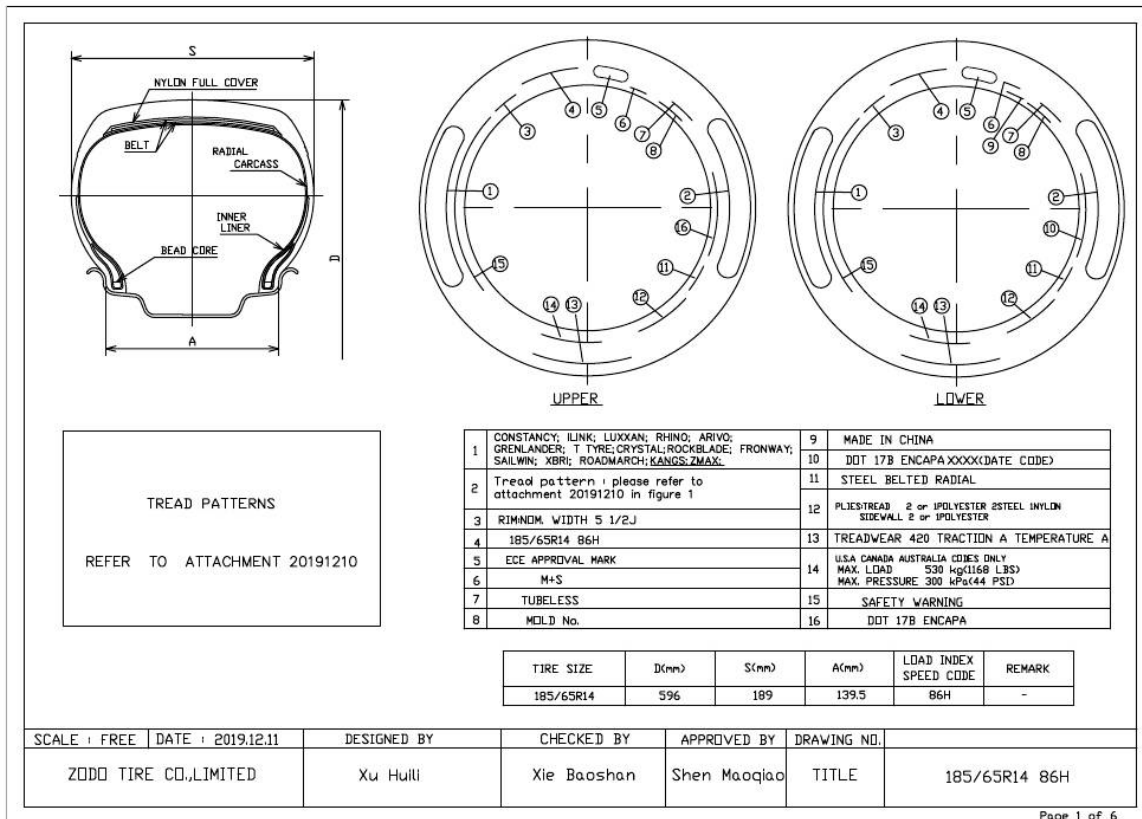

(1) The tyre marking statements are considered leading in case of deviating drawing information.



Test report data delivered by the designated technical service or its laboratory/branch office responsible for conducting the approval tests

Tested in accordance to ECE regulation no. 30, 02 series of amendments, supplement 21

Test reports	:	<table border="1"> <thead> <tr> <th>Date of report</th> <th>Date of test</th> <th>Location of test</th> <th>Reference</th> </tr> </thead> <tbody> <tr> <td>2016-09-17</td> <td>2016-09-14</td> <td>Heze, China</td> <td>extsion number 00</td> </tr> <tr> <td>2020-02-26</td> <td>2020-01-01</td> <td>Heze, China</td> <td>CN20020373</td> </tr> </tbody> </table>	Date of report	Date of test	Location of test	Reference	2016-09-17	2016-09-14	Heze, China	extsion number 00	2020-02-26	2020-01-01	Heze, China	CN20020373
Date of report	Date of test	Location of test	Reference											
2016-09-17	2016-09-14	Heze, China	extsion number 00											
2020-02-26	2020-01-01	Heze, China	CN20020373											
Appropriate test facility, calibrated measurement- and test equipment have been used in compliance with the applicable test requirements	:	Y												
Name and address of designated technical service	:	IDIADA Automotive Technology S.A.Institute for Applied Automotive Research L' Albornar P.O. Box 20 E-43710 Santa Oliva (Tarragona) Spain												
Name and address of branch office of designated technical service	:	N.A.												
Tyre size designation	:	185/65R14												
Brand-name(s) / trademark(s)	:	CONSTANCY, ILINK, LUXXAN, RHINO, ARIVO, GRENLANDER, T TYRE, CRYSTAL, ROCKBLADE, FRONWAY, SAILWIN, XBRI, ROADMARCH, KANGS, ZMAX												
Trade description(s) / commercial name(s)	:	COLO H01, L-GRIP66, LY168, ECOGREEN 66, VENUSATR 66, Energize, PREMIO ARZ1, ECOLOGY, INSPIRER C4, THREE, ROCK 515, PRIMESTAR 66, ENRI U08, EURUS 08, LY169, THUNDER U09, FOUR, VENUSATR 08, ULTRA ARZ4, SPORT+2, INSPIRER S8, ROCK 525, PRIME UHP 08, Envoy, Winter GL868, Winter IL868, LY868, ICEPOWER 868, ICEWINNER 868, WINMASTER ARW2, ROCK 868S, THIRTY TWO, SNOWROVER 868, COMMANDER W7, GREENWING A/S, MULTIMATCH A/S, FRONWING A/S, FREIMATCH A/S, Carlorful A/S, PRIME A/S, ROCK A/S ONE, FORTY ONE, INSPIRER A/S 1, COLO H02, L-GRIP55, ECOGREEN 55, VENUSATR 55, PREMIO ARZERO, INSPIRER ECO, ROCK 555, PRIMESTAR 55, LANDGEMA, LY566, SPORTWAY 56, SPEEDWAY 56, L-ZEAL56, EMOTION, TEN, ULTRA ARZ5, SPORT+, INSPIRER S4, Drift, ROCK 566, MAHO 77, POWERCITY 77, TOPOWER 87 H/T, ROADPOWER H/T, ROADKING H/T, TERRANO ARV H/T, FORZA H/T 2, INSPIRER F4, ROCK 717 H/T, TWENTY TWO, Maxim, PRIMEMARCH H/T 77, MAGA A/T ONE, FORZA A/T, TERRAMAX LSR1 A/T, TERRA XPLOER C1 A/T, GLADIATAX A/T I, ROCKBLADE A/T I, TERRAMAX ARV A/T, INSPIRER A/T I, TOUGH TRAC A/T I, ROCK 727 A/T, PRIMEMAX A/T I, MAGA A/T TWO, FORZA A/T 2, TERRAMAX LSR2 A/T, TERRA XPLOER C2 A/T, GLADIATAX A/T II, ROCKBLADE A/T II, TERRAMAX ARV PRO A/T, INSPIRER A/T II, TOUGH TRAC A/T II, ROCK 737 A/T, PRIMEMAX A/T II, CAPACITY, ECOPRO 99, COLO H03, L-GRIP99, ECOGREEN 99, VENUSATR99, INSPIRER C9, ROCK 999, LANDGEMA II												
Category of use	:	Snow												
Structure	:	Radial												
EMT (Extended Mobility Tyre)	:	N												
Speed category symbol	:	H												
Load capacity index	:	86												
Protective rib	:	N												
Tubeless	:	Y												
Standard / reinforced / T-type temporary use	:	Standard												
Ply-rating number of diagonal (bias-ply) tyres	:	N.A.												
Factor 'x'	:	0.7												
Maximum speed for speed symbol Y for load rating determination	:	N.A.												
Tread-wear indicators	:													
Height of lowest tread-wear indicator	:	1.97 mm												
Height of tallest tread-wear indicator	:	1.99 mm												
Number of transverse rows of wear indicators	:	6												
Special use tread pattern features	:	N.A.												



1 Test data

1.1 Construction variant 1 - 1

1.1.1 MEASURING DATA (ACCORDING TO ANNEX 6)

1.1.1.1 Measuring rim width : 5.5 inch

1.1.1.2 Conditioning

Mounting pressure : 3.0 bar

Adjusted pressure : 1.8 bar

Conditioning time : 24 hrs

Test room temperature : 25 °C

Readjusted pressure : 1.8 bar

1.1.1.3 Measurements

Overall width measured : 195 mm

Calculated outer diameter : 594 mm

1.1.1.4 Plies of tyre subject for type approval

Material	Side wall	Tread
Polyester	1	1
Steel	0	2
Nylon	0	1

1.1.2 LOAD SPEED PERFORMANCE TEST (ACCORDING TO ANNEX 7)

1.1.2.1 Reference is made to a worst case tyre out of the tyre range : N

1.1.2.2 Test setup

Test drum diameter : 1.70 m

Test rim width : 5.5 inch

Test axle load : 424 kg

1.1.2.3 Conditioning

Test inflation pressure : 2.8 bar

The test inflation pressure differs from those given under Annex 7 paragraph 1.2 : N

Conditioning time : 3 hrs

Test room temperature : 25 °C

Readjusted pressure : 2.8 bar

1.1.2.4 Outer diameter before test : 594 mm

1.1.2.5 Test procedure

Time from zero to initial test speed : 10 min

Test steps :

Step	Duration (min)	Speed (km/h)
1.	10	170
2.	10	180
3.	10	190
4.	20	200

1.1.2.6 Test results

Traces of tread separation, ply separation, cord separation, chunking or broken cords after the load/speed test : N

Superficial blistering after the load/speed test caused by the specific test equipment and conditions : N

Conditioning time after test : 6 hrs

Calculated outer diameter of measured circumference after test : 595 mm

Change in outer diameter after test : 0.17 %



1.2 Construction variant 2 - 2

1.2.1 MEASURING DATA (ACCORDING TO ANNEX 6)

1.2.1.1	Measuring rim width	:	5.5 inch
1.2.1.2	Conditioning		
	Mounting pressure	:	3 bar
	Adjusted pressure	:	1.8 bar
	Conditioning time	:	24 hrs
	Test room temperature	:	25 °C
	Readjusted pressure	:	1.8 bar
1.2.1.3	Measurements		
	Overall width measured	:	190 mm
	Calculated outer diameter	:	596 mm
1.2.1.4	Plies of tyre subject for type approval	:	

Material	Side wall	Tread
Polyester	2	2
Steel	0	2
Nylon	0	1

1.2.2 LOAD SPEED PERFORMANCE TEST (ACCORDING TO ANNEX 7)

1.2.2.1	Reference is made to a worst case tyre out of the tyre range	:	N
1.2.2.2	Test setup		
	Test drum diameter	:	1.70 m
	Test rim width	:	5.5 inch
	Test axle load	:	424 kg
1.2.2.3	Conditioning		
	Test inflation pressure	:	2.8 bar
	The test inflation pressure differs from those given under Annex 7 paragraph 1.2	:	N
	Conditioning time	:	3 hrs
	Test room temperature	:	25 °C
	Readjusted pressure	:	2.8 bar
1.2.2.4	Outer diameter before test	:	597 mm
1.2.2.5	Test procedure		
	Time from zero to initial test speed	:	10 min
	Test steps	:	

Step	Duration (min)	Speed (km/h)
1.	10	170
2.	10	180
3.	10	190
4.	20	200

1.2.2.6	Test results		
	Traces of tread separation, ply separation, cord separation, chunking or broken cords after the load/speed test	:	N
	Superficial blistering after the load/speed test caused by the specific test equipment and conditions	:	N
	Conditioning time after test	:	6 hrs
	Calculated outer diameter of measured circumference after test	:	599 mm
	Change in outer diameter after test	:	0.34 %



2 TYRE MARKINGS	STATEMENT ⁽¹⁾
2.1 Brand name or trade mark	: Marked
2.2 Trade description / commercial name	: Marked
2.3 Date of manufacture	: Marked
- character height \geq 4 mm	: Y
2.4 Upper side wall markings	
"TEMPORARY USE ONLY"	: N.A.
"INFLATE TO 420kPa (60 psi)"	: N.A.
2.5 Lower side wall markings	
Approval mark in accordance to article 3.2, 3.4, 5.4 and Annex 2	: Y
Tyre structure letter code	: R
Tyre to rim fitment code	: N.A.
Service description	
- marked within brackets	: N.A.
- immediately after tyre size designation	: Y
- character height \geq 6mm	: Y
"RADIAL"	: Marked
- character height \geq 4 mm	: Y
"B" and "BIAS BELTED"	: N.A.
"TUBELESS"	: Marked
- character height \geq 4 mm	: Y
Run flat symbol	: N.A.
EMT (Extended mobility tyre) symbol	: N.A.
"REINFORCED" or "EXTRA LOAD"	: N.A.
"M+S"/"M.S"/"M&S"	: Marked
- character height \geq 4 mm	: Y
"ET"	: N.A.
"POR"	: N.A.
Location of the applicable mandatory markings	: In lower area
Symmetrical tyres marked on both sidewalls	: Y
Asymmetrical tyres marked at least on the outer tyre side wall	: Y

3 Nominal envelop dimensions of the inflated tyre mounted on the measuring rim ⁽¹⁾

S	: 189 mm
D	: 596 mm
A	: 140 mm

⁽¹⁾ The tyre marking statements are considered leading in case of deviating drawing information.



APPLICATION FOR APPROVAL OF A TYPE OF PNEUMATIC TYRE FOR TYRES FOR MOTOR VEHICLES AND THEIR TRAILERS ACCORDING TO ECE REGULATION No. 30, 02 SERIES OF AMENDMENTS, SUPPLEMENT 21

- 4.1 Name and address of manufacturer (applicant) : ZODO TIRE Co., LIMITED
The South of Yalujiang Road, Wenzhuang Village Qinghe Agency of Cao County Heze City
Shandong Province 274400
China(PRC)
- Name and address of branch office of designated technical service (manufacturers duly accredited representative) : N.A.
- 4.1.1 Tyre size designation : 185/65R14
- 4.1.2.1 Brand-name(s) / trademark(s) : CONSTANCY, ILINK, LUXXAN, RHINO, ARIVO, GRENLANDER, T TYRE, CRYSTAL, ROCKBLADE, FRONWAY, SAILWIN, XBRI, ROADMARCH, KANGS, ZMAX
- 4.1.2.2 Trade description(s) / commercial name(s) : COLO H01, L-GRIP66, LY168, ECOGREEN 66, VENUSATR 66, Energize, PREMIO ARZ1, ECOLOGY, INSPIRER C4, THREE, ROCK 515, PRIMESTAR 66, ENRI U08, EURUS 08, LY169, THUNDER U09, FOUR, VENUSATR 08, ULTRA ARZ4, SPORT+2, INSPIRER S8, ROCK 525, PRIME UHP 08, Envoy, Winter GL868, Winter IL868, LY868, ICEPOWER 868, ICEWINNER 868, WINMASTER ARW2, ROCK 868S, THIRTY TWO, SNOWROVER 868, COMMANDER W7, GREENWING A/S, MULTIMATCH A/S, FRONWING A/S, FREIMATCH A/S, Carlorful A/S, PRIME A/S, ROCK A/S ONE, FORTY ONE, INSPIRER A/S 1, COLO H02, L-GRIP55, ECOGREEN 55, VENUSATR 55, PREMIO ARZERO, INSPIRER ECO, ROCK 555, PRIMESTAR 55, LANDGEMA, LY566, SPORTWAY 56, SPEEDWAY 56, L-ZEAL56, EMOTION, TEN, ULTRA ARZ5, SPORT+, INSPIRER S4, Drift, ROCK 566, MAHO 77, POWERCITY 77, TOPOWER 87 H/T, ROADPOWER H/T, ROADKING H/T, TERRANO ARV H/T, FORZA H/T 2, INSPIRER F4, ROCK 717 H/T, TWENTY TWO, Maxim, PRIMEMARCH H/T 77, MAGA A/T ONE, FORZA A/T, TERRAMAX LSR1 A/T, TERRA XPLOER C1 A/T, GLADIATAX A/T I, ROCKBLADE A/T I, TERRAMAX ARV A/T, INSPIRER A/T I, TOUGH TRAC A/T I, ROCK 727 A/T, PRIMEMAX A/T I, MAGA A/T TWO, FORZA A/T 2, TERRAMAX LSR2 A/T, TERRA XPLOER C2 A/T, GLADIATAX A/T II, ROCKBLADE A/T II, TERRAMAX ARV PRO A/T, INSPIRER A/T II, TOUGH TRAC A/T II, ROCK 737 A/T, PRIMEMAX A/T II, CAPACITY, ECOPRO 99, COLO H03, L-GRIP99, ECOGREEN 99, VENUSATR99, INSPIRER C9, ROCK 999, LANDGEMA II
- 4.1.3 Category of use : Snow
- 4.1.3.1 For the tyres belonging to the category of use "special use tyre" those which may bear the inscription M+S or M.S or M&S : N.A.
- 4.1.4 Structure : Radial
- 4.1.5 Speed category symbol : H
- 4.1.6 Load capacity index : 86
- 4.1.7 Tubeless : Y
- 4.1.8 Standard / reinforced / T-type temporary use : Standard
- 4.1.9 EMT (Extended mobility tyre) : N
- 4.1.10 Ply-rating number of diagonal (bias-ply) tyres; except for T-type temporary use spare tyres : N.A.
- 4.1.11 The overall dimensions: overall section width and outer diameter : Values per construction variant
- | # | Overall section width (mm) | Outer diameter (mm) |
|---|----------------------------|---------------------|
| 1 | 195 | 594 |
| 2 | 190 | 596 |
- 4.1.12 The rims on which the tyre can be mounted : 5.5 inch
- 4.1.13 The measuring rim and test rim : Values per construction variant
- | # | Measuring rim (inch) | Test rim (inch) |
|---|----------------------|-----------------|
| 1 | 5.5 | 5.5 |
| 2 | 5.5 | 5.5 |
- 4.1.14 The test pressure where the manufacture requests the application of Annex 7 paragraph 1.3 to this Regulation : Values per construction variant
- | # | Test inflation pressure (bar) |
|---|-------------------------------|
| 1 | N.A. |
| 2 | N.A. |
- 4.1.15 The factor 'x' : 0.7
- 4.1.16 For tyres suitable for speeds in excess of 300 km/h, the maximum speed permitted by the tyre manufacturer and the : N.A.



- load carrying capacity allowed for that maximum speed
- 4.1.17 The identification of the bead retention rim contours specific for the "flat tyre running mode" of "run flat tyres" : N.A.
- 4.2 The application for approval is accompanied by drawings or images of
1. The tyre tread pattern : Y
 2. Envelope of the inflated tyre mounted on the measuring rim, showing the relevant dimensions (see paragraphs 6.1.1 and 6.1.2) : Y
 3. The side wall showing the relevant markings : Y
- 4.4 Reference to Worst-case tyre has been made for the load-speed test. The worst case tyre selection criteria can be obtained from the approval authority. : Values per construction variant

#	Worst case
1	N
2	N



Reason(s) of extension : Update of tyre type designation(s);
Upgrade of regulation supplement number;
Update of construction variant(s);
Upgrade of the type approval number;
Change of technical service;
Addition of brand names; Addition of trade descriptions; Modification of
manufacturer's name

The applicant, as defined in article in 4.1, declares that:

- This application is in compliance with the scope as defined in chapter 1 of the regulation.
- All data for this application are unambiguously and truthfully given.
- The type approval application for the subject component is submitted only at RDW as Contracting party pursuant to this UN regulation.
- Appropriate test facility, calibrated measurement and test equipment have been used in compliance with the applicable test requirements.

Company : IDIADA Automotive Technology S.A. Institute for Applied Automotive
Research
Name of person responsible for the submitted application data : Lluís Sans Gomis
Function of above mentioned authorised person : DEPARTMENT MANAGER
E-mail address of department or above mentioned authorised
person : lsans@idiada.com
Place of submission : L'Albornar, Santa Oliva (Tarragona)
Submitted for approval on (date) : 13/03/2020 12:54:44
Reference id of the application given by the applicant :

