

Operator's Manual

Road Sweeper

Swlt-140-190-220

3250200654

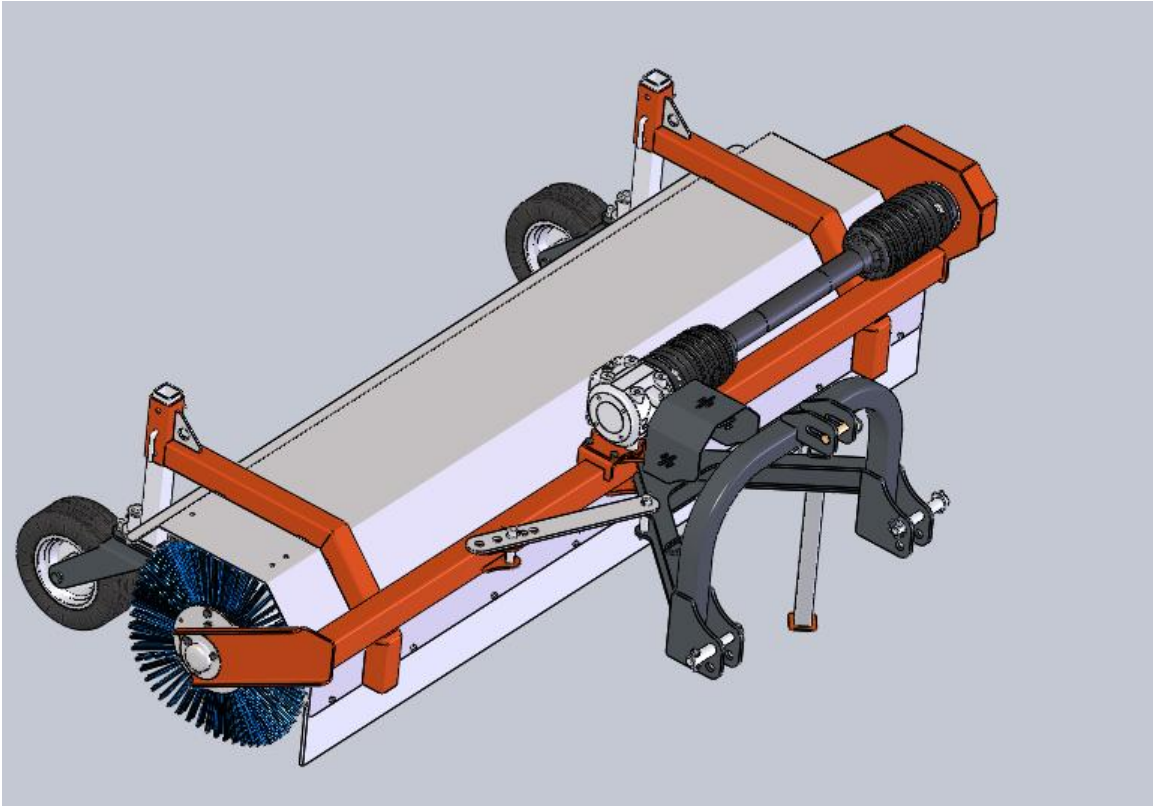

MATENG[®]

Read the Operator's Manual entirely. When you see this symbol, the subsequent instructions and warnings are serious - follow without exception your life and the lives of others depend on it!

Important Safety Information	1	Section 3: Maintenance & Lubrication	15
Safety at All Times	1	Storage	15
Look For The Safety Alert Symbol	1	Lubrication Points	15
Safety labels	4	Section 4 : detailed parameters.	16
Introduction	7	Section 5 : Part List.	17
Application	7	Page No.1.	17
Using This Manual	7	Page No.2	19
Terminology	7	Page No.3	20
Definitions	7	Page No.4.	21
Owner Assistance	7	Page No.5	22
Serial Number	7	Page No.6	23
Further Assistance	8	Page No.7	24
Section 1: Assembly & Set-up	9	Page No.8	25
Torque Requirements	9	Page No.9.	26
Hitch Assembly	9	Page No.10	27
Tractor Requirements	10	Page No.11.	28
Tractor Hook-Up	10	Page No.12.	29
Driveline Installation	10	Page No.13.	30
Check Driveline Collapsible Length	11	Section 6: Warranty	31
Shorten Driveline Length	11		
Check Driveline Extended Length	12		
Check Driveline Interference	12		
Section 2: Operating Instructions	13		
Pre-Start Checklist	13		
Tractor Shut Down Procedure	13		
Transporting	13		
Safety Information	13		
working Instructions	14		
Operating Instructions	14		
General Operating Instructions	14		

© Copyright 2015 All rights Reserved

MATENG provides this publication “as is” without warranty of any kind, either expressed or implied. While every precaution has been taken in the preparation of this manual, MATENG assumes no responsibility for errors or omissions. Neither is any liability assumed for damages resulting from the use of the information contained herein. MATENG reserves the right to revise and improve its products as it sees fit. This publication describes the state of this product at the time of its publication, and may not reflect the product in the future.

MATENG is a registered trademark.
All other brands and product names are trademarks or registered trademarks of their respective holders.

These are common practices that may or may not be applicable to the products described in this manual.

Safety at All Times

Thoroughly read and understand the instructions given in this manual before operation. Refer to the "Safety Label" section, read all instructions noted on them.

Do not allow anyone to operate this equipment who has not fully read and comprehended this manual and who has not been properly trained in the safe operation of the equipment.

- ▲ Operator should be familiar with all functions of the unit.
- ▲ Operate implement from the driver's seat only.
- ▲ Make sure all guards and shields are in place and secured before operating implement.
- ▲ Do not leave tractor or implement unattended with engine running.
- ▲ Dismounting from a moving tractor could cause serious injury or death.
- ▲ Do not allow anyone to stand between tractor and implement while backing up to implement.
- ▲ Keep hands, feet, and clothing away from power-driven parts.
- ▲ Wear snug fitting clothing to avoid entanglement with moving parts.
- ▲ Watch out for wires, trees, etc., when raising implement. Make sure all persons are clear of working area.
- ▲ Turning tractor too tight may cause implement to ride up on wheels. This could result in injury or equipment damage.
- ▲ Do not carry passengers on implement at any time.



Look For The Safety Alert Symbol

The SAFETY ALERT SYMBOL indicates there is a potential hazard to personal safety involved and extra safety precaution must be taken. When you see this symbol, be alert and carefully read the message that follows it. In addition to design and configuration of equipment, hazard control, and accident prevention are dependent upon the awareness, concern, prudence, and proper training of personnel involved in the operation, transport, maintenance, and storage of equipment.

Be Aware of Signal Words

A Signal word designates a degree or level of hazard seriousness. The signal words are:

⚠ DANGER

Indicates an imminently hazardous situation which, if not avoided, will result in death or serious injury. This signal word is limited to the most extreme situations, typically for machine components that, for functional purposes, cannot be guarded.

⚠ WARNING

Indicates a potentially hazardous situation which, if not avoided, could result in death or serious injury, and includes hazards that are exposed when guards are removed. It may also be used to alert against unsafe practices.

⚠ CAUTION

Indicates a potentially hazardous situation which, if not avoided, may result in minor or moderate injury. It may also be used to alert against unsafe practices.

For Your Protection

- ▲ Thoroughly read and understand the "Safety Label" section, read all instructions noted on them.



Shutdown and Storage

- ▲ Lower machine to ground, put tractor in park, turn off engine, and remove the key.
- ▲ Detach and store implements in a area where children normally do not play. Secure implement by using blocks and supports.

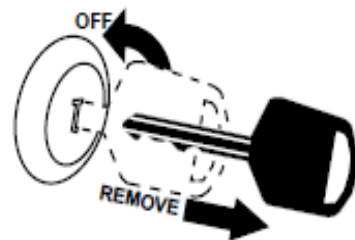

These are common practices that may or may not be applicable to the products described in this manual.

Use Safety Lights and Devices

- ▲ Slow moving tractors, self-propelled equipment, and towed implements can create a hazard when driven on public roads. They are difficult to see, especially at night.
- ▲ Flashing warning lights and turn signals are recommended whenever driving on public roads.

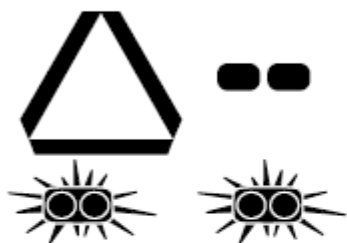

Transport Machinery Safely

- ▲ Comply with state and local laws.
- ▲ Maximum transport speed for implement is 20 mph. **DO NOT EXCEED.** Never travel at a speed which does not allow adequate control of steering and stopping. Some rough terrain require a slower speed.
- ▲ Sudden braking can cause a towed load to swerve and upset. Reduce speed if towed load is not equipped with brakes.

- ▲ Use the following maximum speed - tow load weight ratios as a guideline:
 - 20 mph** when weight is less than or equal to the weight of tractor.
 - 10 mph** when weight is double the weight of tractor.
- ▲ **IMPORTANT:** Do not tow a load that is more than double the weight of tractor.

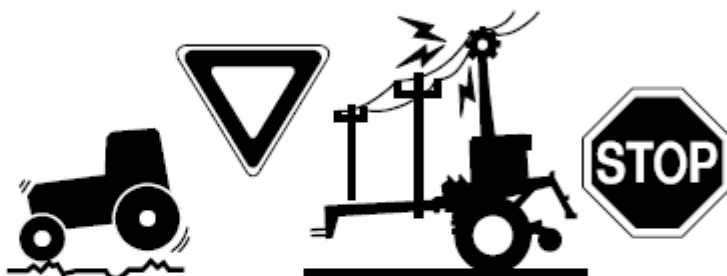

Practice Safe Maintenance

- ▲ Understand procedure before doing work. Use proper tools and equipment, refer to Operator's Manual for additional information.
- ▲ Work in a clean dry area.
- ▲ Lower the implement to the ground, put tractor in park, turn off engine, and remove key before performing maintenance.
- ▲ Allow implement to cool completely.
- ▲ Do not grease or oil implement while it is in operation.
- ▲ Inspect all parts. Make sure parts are in good condition & installed properly.
- ▲ Remove buildup of grease, oil, or debris.
- ▲ Remove all tools and unused parts from implement before operation.



These are common practices that may or may not be applicable to the products described in this manual.

Prepare for Emergencies

- ▲ Be prepared if a fire starts.
- ▲ Keep a first aid kit and fire extinguisher handy.
- ▲ Keep emergency numbers for doctor, ambulance, hospital, and fire department near phone.



Wear Protective Equipment

- ▲ Wear protective clothing and equipment appropriate for the job. Avoid loose fitting clothing.
- ▲ Prolonged exposure to loud noise can cause hearing impairment or hearing loss. Wear suitable hearing protection such as earmuffs or earplugs.
- ▲ Operating equipment safely requires the full attention of the operator. Avoid wearing radio headphones while operating machinery.



Avoid High Pressure Fluids Hazard

- ▲ Escaping fluid under pressure can penetrate the skin causing serious injury.
- ▲ Avoid the hazard by relieving pressure before disconnecting hydraulic lines or performing work on the system.
- ▲ Make sure all hydraulic fluid connections are tight and all hydraulic hoses and lines are in good condition before applying pressure to the system.
- ▲ Use a piece of paper or cardboard, NOT BODY PARTS, to check for suspected leaks.
- ▲ Wear protective gloves and safety glasses or goggles when working with hydraulic systems.
- ▲ If an accident occurs, see a doctor immediately. Any fluid injected into the skin must be treated within a few hours or gangrene may result.



Keep Riders Off Machinery

- ▲ Riders obstruct the operator's view, they could be struck by foreign objects or thrown from the machine.
- ▲ Never allow children to operate equipment.



Tire Safety

- ▲ Tire changing can be dangerous and should be performed by trained personnel using the correct tools and equipment.
- ▲ When inflating tires, use a clip-on chuck and extension hose long enough to allow you to stand to one side and NOT in front of or over the tire assembly. Use a safety cage if available.
- ▲ When removing and installing wheels, use wheel handling equipment adequate for the weight involved.



Safety labels

Your Road Sweeper comes equipped with all safety labels in place. They were designed to help you safety operate your implement. Read and follow the directions.

1. Refer to this section for proper label placement.
Replace all damaged or missing labels. Order new labels from your nearest dealer.
2. Some new equipment installed during repair requires safety labels to be affixed to the replaced component as specified by Mateng. When ordering new components

make sure the correct safety labels are included in the request.

3. Refer to this section for proper label placement.

To install new labels:

- a. Clean the area the label is to be placed.
- b. Spray soapy water on the surface where the label is to be placed.
- c. Peel backing from label. Press firmly onto the surface.
- d. Squeeze out air bubbles with the edge of a credit card or with a similar type straight edge.

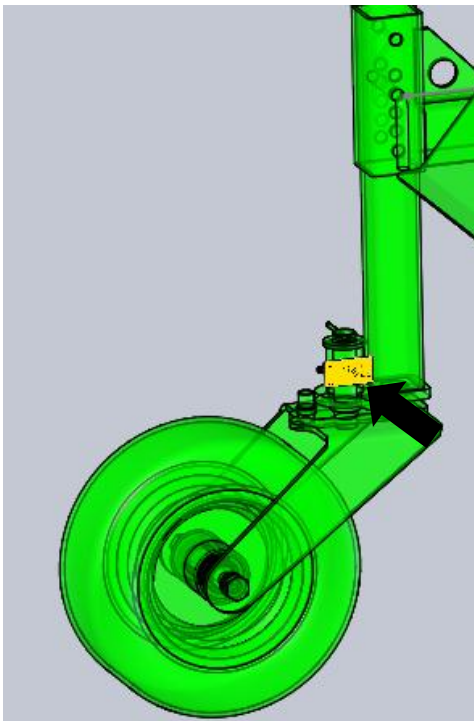
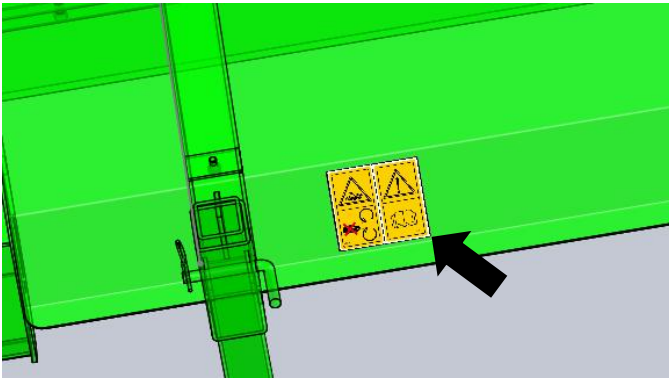

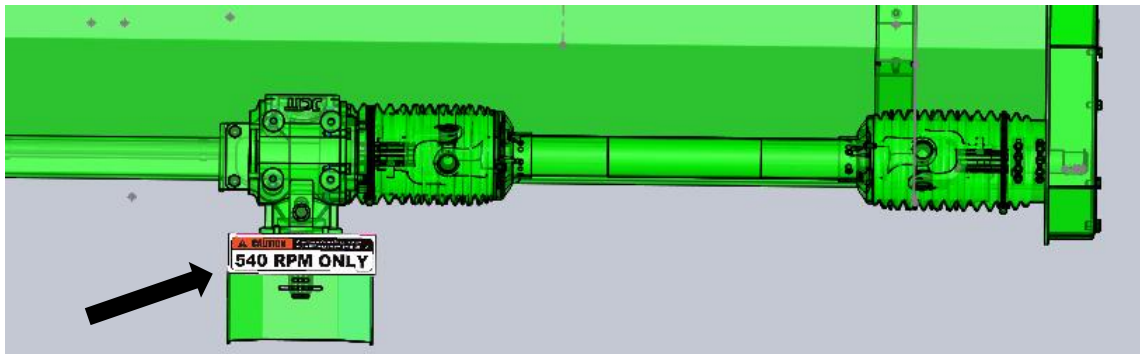
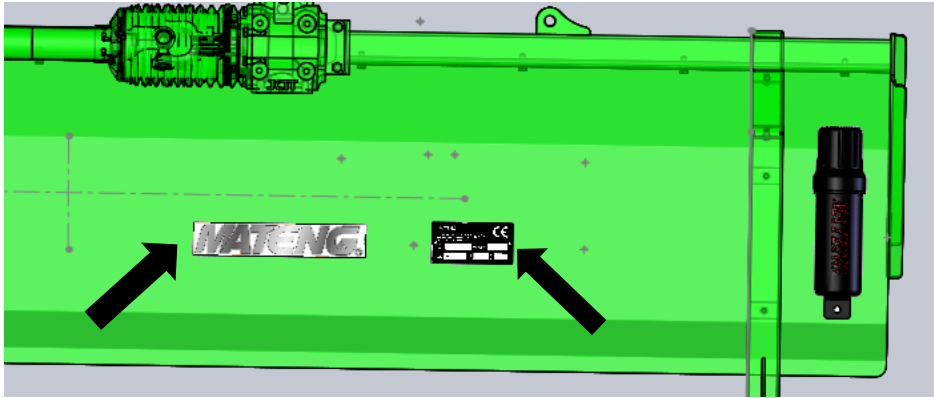

⚠ CAUTION

Consult tractor Owner's Manual for proper engine RPM to achieve 540 RPM at rear PTO.

540 RPM ONLY

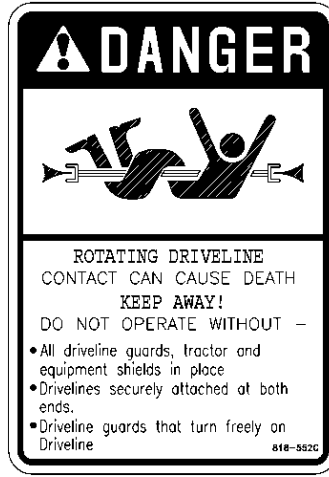
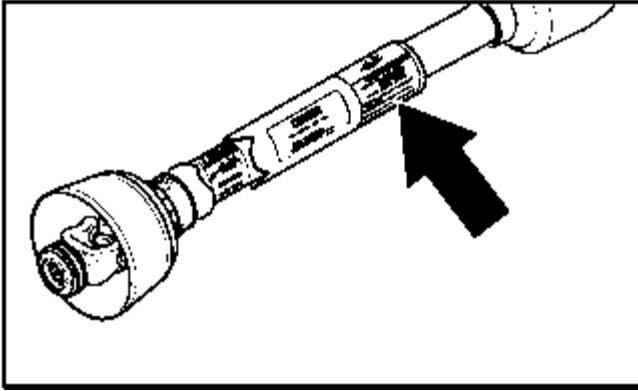

Danger: Rotating Driveline

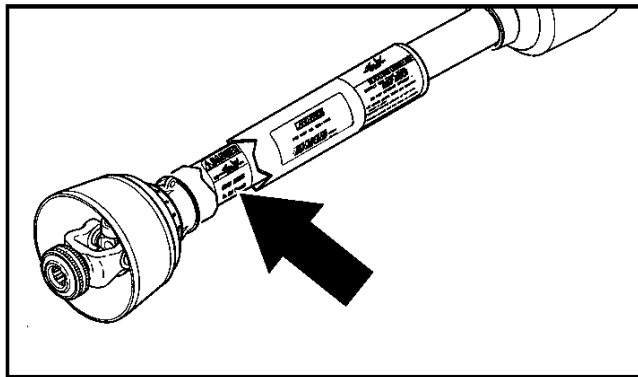

Danger: Guard Missing

Introduction

MATENG welcomes you to the growing family of new product owners. This Road Sweeper has been designed with care and built by skilled workers using quality materials. Proper assembly, maintenance, and safe operating practices will help you get years of satisfactory use from this machine.

Using This Manual

- This Operator’s Manual is designed to help familiarize you with safety, assembly, operation, adjustments, troubleshooting, and maintenance. Read this manual and follow the recommendations to help ensure safe and efficient operation.
- The information contained within this manual was current at the time of printing. Some parts may change slightly to assure you of the best performance.
- To order a new Operator’s or Parts Manual contact your authorized dealer. Manuals can also be downloaded, free-of-charge from our website at www.Mateng.com.

Terminology

“Right” or “Left” as used in this manual is determined by facing the direction the machine will operate when used unless otherwise stated.

Definitions

IMPORTANT: A special point of information related to the following topic. MATENG’s intention is this information must be read & noted before continuing.

NOTE: A special point of information that the operator should be aware of before continuing.

Owner Assistance

The Online Warranty Registration or Warranty Registration card should be completed by the dealer at the time of purchase. This information is to necessary provide you with quality customer service.

The parts on your Road Sweeper have been specially designed by MATENG and should only be replaced with genuine MATENG parts. Contact a MATENG dealer if customer service or repair parts are required. Your MATENG dealer has trained personnel, repair parts, and equipment needed to service the implement.

Serial Number

Model No. _____ Serial No. _____

For quick reference and prompt service, record model and serial number in the spaces provided above and again on warranty page 37. Always provide model and serial number when ordering parts and in all correspondences with your MATENG dealer. Refer to Figure 1 for location of your serial number plate.

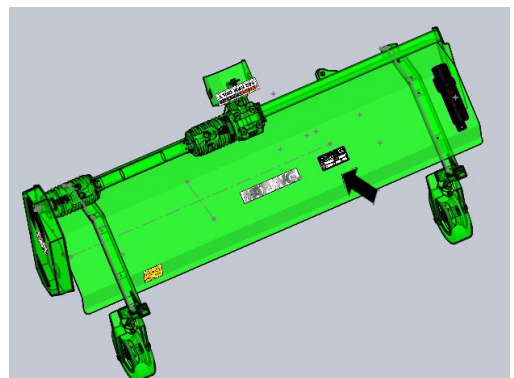

Serial Number Plate Location
Figure 1

Further Assistance

Your dealer wants you to be satisfied with your new Mowers.

If for any reason you do not understand any part of this manual or are not satisfied with the service received, the following actions are suggested:

1. Discuss the matter with your dealership service manager making sure that person is aware of any problems you may have and has had the opportunity to assist you.
2. If you are still not satisfied, seek out the owner or general manager of the dealership, explain the problem, and request assistance.
3. For further assistance write to:

Changzhou Mateng Machinery Co., Ltd.
10# Chuangsheng Road, LuoYang Industrial Park,
Wujin District, Changzhou City ,Jiangsu Province ,P.R.of China 213104
Tel: 0086-519-8823 8398
Fax: 0086-519-8823 8397
E-mail address
mateng@mateng.com

Tractor Requirements

Tractor horsepower and hitch category should be within the range noted below. Tractors outside the horsepower range must not be used. The lower 3-Point arms must be stabilized to prevent side-to-side movement. Most tractors have sway blocks or adjustable chains for this purpose.

Horsepower Rating	70-90 HP
Hitch Type	3-Point Cat II
Rear PTO Speed	.540 RPM
Tractor Weight	See Important Note Below

Tractor Hook-up

Refer to Figure 1-2:

1. Be certain tractor draw bar does not interfere. Move draw bar ahead or remove if required. Draw bar should also be checked for clearance when unit is raised for the first time.
2. Remove all three clevis hitch pins.

3. Align ball swivels in the tractor's lower 3-Point arms with pin holes in the lower hitch clevises of the Mowers . Insert hitch pins and secure with hair pin cotter.
4. Align the top center link with the center hitch Clevis of the Mowers. Insert hitch pin and secure with hair pin cotter.
5. With tractor's 3-Point controls, lift Mowers up 1 to 2 inches and then raise jack stands fully up. Secure stands with jack pins and hair pin cotter.
6. Level Road Sweeper by adjusting lower 3-Point arms and upper center link.

Driveline Installation

! DANGER

Do not engage tractor PTO while hooking-up and unhooking driveline or stand near a rotating driveline. A person's body and/or clothing can become entangled

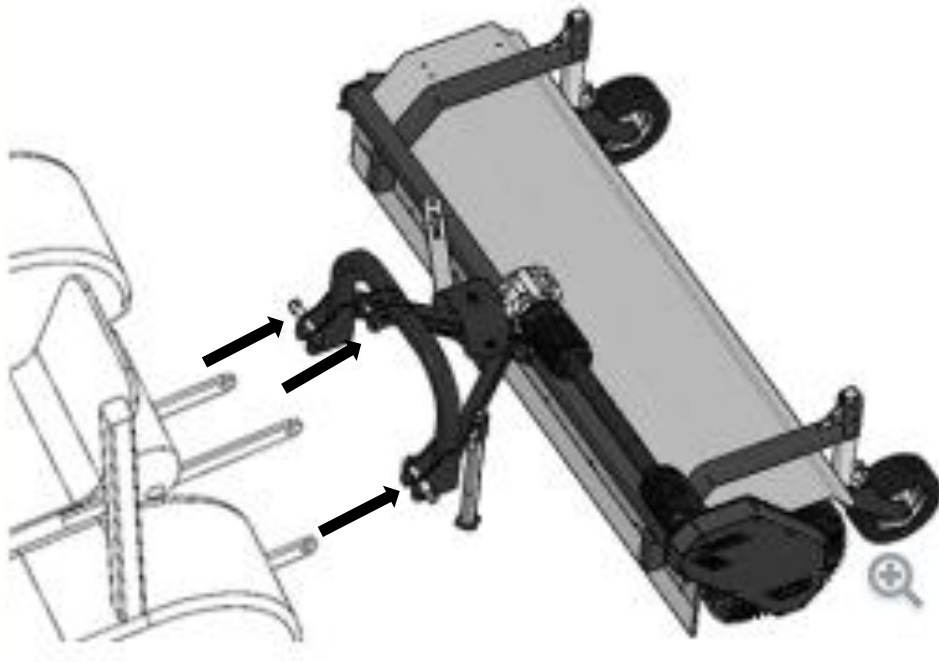

Tractor Hook-Up
Figure 1-2

Driveline installation

Refer to Figure 1-3:

1. Park tractor on a level surface. Slowly engage tractor 3-Point lift lever to raise Mowers until gearbox shaft is in line (level) with tractor PTO shaft.
2. Support Mowers deck at this height with support jacks or blocks to keep Mowers from drifting down.
3. Place gear selector in park, set park brake, shut tractor off, and remove switch key.
4. Slide inner yoke (implement end) of driveline onto the gearbox. Secure driveline with yoke locking device.
5. Slide outer yoke of driveline over the tractor PTO shaft. Secure driveline with yoke locking device.
6. If driveline does not fit between tractor and gearbox, skip to instructions to **“Shorten Driveline Length”** on this page.
7. The driveline should now be moved back and forth to ensure both ends are secured to the tractor and poultry litter crusher PTO shafts. Reattach any end that is loose.
8. Hook driveline safety chain on the tractor end of driveline to the tractor. Re-latch safety chain to the driveline shield.
9. Hook driveline safety chain on the Mowers end of driveline to the Mowers frame. Re-latch safety chain to the driveline shield.

1. Make sure driveline is properly installed and level before checking driveline collapsible length. (Refer to **“Driveline Installation”** on page 10 if needed.)

Refer to Figure 1-3:

2. With driveline level, measure 1" (**“B”** dimension) back from universal joint shield to end of outer driveline shield. If measurement is 1" or more, skip **“Check Driveline Extended Length”** on page 12. If measurement is less than 1", then continue with **“Shorten Driveline Length”** on this page.

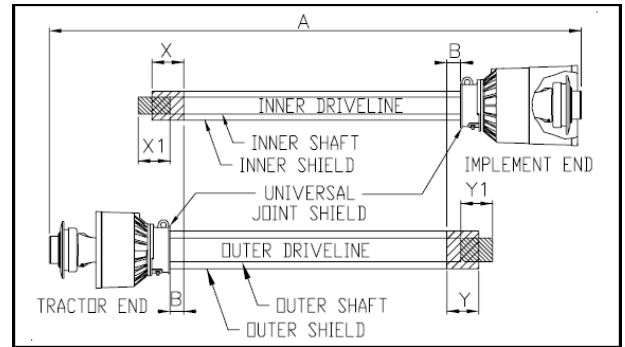

Driveline Shortening Figure 1-3

Check Driveline Collapsible Length

IMPORTANT: Two small chains are supplied with the driveline. To keep driveline shields from rotating, these chains must be attached to the outer and inner driveline shields and to the Mowers and tractor.

IMPORTANT: A driveline that is too long will bottom out causing structural damage to the tractor and Mowers. Always check driveline collapsible length during initial setup and when connecting to a different tractor. More than one driveline may be required to fit all applications.

Shorten Driveline Length

Refer to Figure 1-3:

1. Un-hook driveline from tractor PTO shaft and pull outer and inner drivelines apart.
2. Reattach outer driveline to tractor PTO shaft. Pull on inner and outer drivelines to be sure universal joints are properly secured.
3. Hold inner and outer drivelines parallel to each other:
 - a. Measure 1" (**“B”** dimension) back from outer driveline universal joint shield and make a mark at this location on the inner driveline shield.
 - b. Measure 1" (**“B”** dimension) back from the inner driveline universal joint shield and make a mark at this location on the outer driveline shield.
4. Remove driveline from tractor and gearbox shafts.
5. Measure from end of inner shield to scribed mark (**“X”** dimension). Cut off inner shield at the mark. Cut same amount off the inner shaft (**“X1”** dimension).
6. Measure from end of outer shield to scribed mark (**“Y”** dimension). Cut off outer shield at the mark. Cut same amount off the outer shaft (**“Y1”** dimension).
7. Remove all burrs and Crushings.
8. Check drive line extend length next.

Check Driveline Extended Length

Refer to Figure 1-4:

Make sure driveline collapsible length is acceptable. If needed, refer to “**Check Driveline Collapsible Length**” on page 11 instructions on this page.

The driveline maximum allowable length must, when fully extended, have a minimum overlap of the profile tubes by not less than 1/3 the free length with both inner and outer profile tubes being of equal length.

1. Apply multi-purpose grease to the inside of the outer shaft and reassemble the driveline.
2. Assemble driveline profiles together with 1/3 overlapping of inner and outer profile tubes. Once assembled, measure and record the maximum allowable length shown below for future reference.

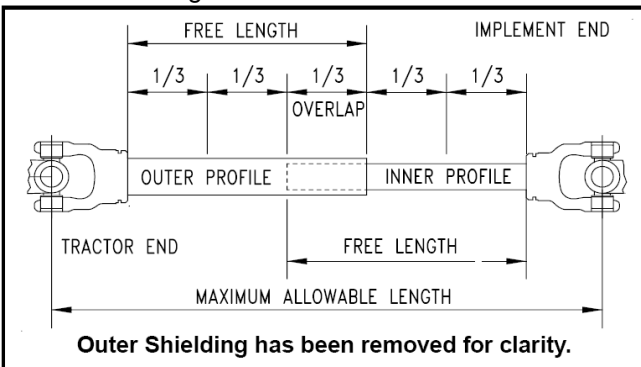

Driveline Maximum Extended Length

Figure 1-4

3. Attach inner driveline yoke to the Mowers gearbox shaft. Attach outer driveline yoke to the tractor's PTO shaft.
4. Move yoke ends of driveline back and forth to ensure they are secured to the tractor and Mowers shafts. Reattach any end that is loose.

IMPORTANT: Small chains are supplied with the driveline. They must be attached to the inner and outer driveline shields and to the Mowers and tractor to restrict shield rotation.

5. Hook driveline safety chain on the tractor end of driveline to the tractor. Re-latch safety chain to the driveline shield.
6. Hook driveline safety chain on the Mowers end of driveline to the Mowers frame. Re-latch safety chain to the driveline shield.
7. Start tractor and raise Mowers just enough to remove blocks.

8. Slowly engage tractor hydraulic 3-Point control lever to lower Mowers. Check for sufficient drawbar clearance. Move drawbar ahead, aside or remove if required.
9. Raise and lower implement to find maximum extended driveline length. Check to make certain that the driveline overall length does not exceed the maximum recorded length in step 2.
10. If needed, set tractor 3-Point lift height to keep driveline from exceeding maximum allowable length.

Check Driveline Interference

Refer to Figure 1-5:

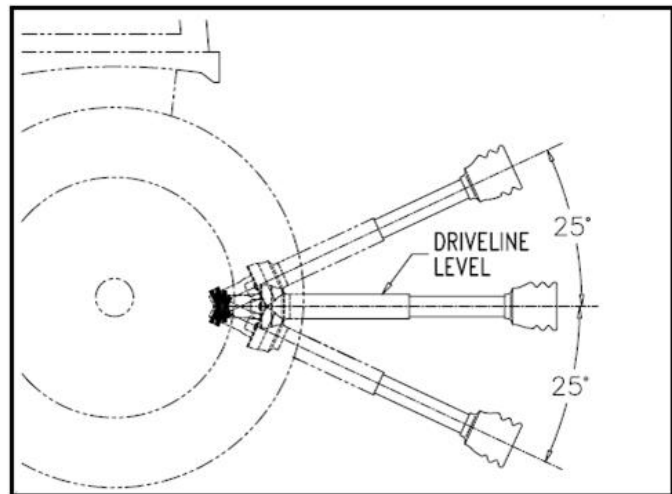

Maximum PTO Driveline Movement During Operation

Figure 1-5

1. Slowly engage tractor hydraulic 3-Point control lever to lower Mowers while checking for sufficient drawbar clearance. Move drawbar ahead, aside, or remove if required.
2. Raise and lower implement to find maximum extended driveline length. Check to make certain the driveline does not exceed the maximum allowable length and 25° up or down.
3. If needed, set tractor 3-Point lift height to keep driveline from exceeding the maximum allowable length and 25° up.

Pre-Start Checklist

Hazard control and accident prevention are dependent upon the awareness, concern, prudence, and proper training involved in the operation, transport, storage, and maintenance of the Mowers. Therefore, it is absolutely essential that no one operates the poultry litter Crusher without first having read, fully understood, and Become totally familiar with the Operator’s Manual. Make sure the operator has read and paid particular attention to:

- **Important Safety Information**, page 1
- **Section 1: Assembly & Set-up**, page 9
- **Section 2: Operating Instructions**, page 13
- **Section 3: Adjustments**, page 16
- **Section 4: Maintenance & Lubrication**, page 18

Make sure the operator has completed the Operating Checklist below.

✓	Check	Page No.
	Read and follow all Safety Information carefully. Refer to "Important Safety Information".	Page 1
	Make sure all guards and shields are in place. Refer to "Important Safety Information".	Page 1
	Read and follow 3-Point hook-up & preparation instructions. Refer to "Assembly & Set-up".	Page 9
	Read and made all required adjustments. Refer to "Section 3: Adjustments".	Page 16
	Read and follow all operating procedures. Refer to "Section 2: Operating Instructions".	Page 13
	Read and follow all Maintenance Instructions. Refer to "Section 4: Maintenance & Lubrication".	Page 18
	Read and follow all Lubrication Instructions. Refer to "Lubrication Points".	Page 19
	Make sure all gearboxes are properly lubricated. Refer to Gearbox Lubrication lubrication.	Page 19
	Check Mowers initially and periodically for loose bolts and pins. Be sure all lock nut s and bolts are tight. Especially make sure blade bolts are tight. Refer to "Torque Values Chart for Common Bolt Sizes".	Page 36

1. Park tractor on a level surface.
Don't work under or around an implement parked on a steep incline.
2. Place tractor in park and set park brake.
3. Disengage PTO if operating.
4. Shut engine off and remove switch key.
5. Wait for PTO to come to a complete stop before dismounting tractor.
6. Wear safety glasses.

Transporting

! CAUTION

When traveling on public roads whether at night or during the day, use accessory light and devices for adequate warning to operators of other vehicles. Comply with all federal, state, and local laws.

1. When raising Mowers to transport position, be sure driveline does not contact tractor or Mowers. Adjust and set tractor’s 3-Point lift height so that the driveline does not contact Road Sweeper deck in the fully raised position.
2. Be sure to reduce tractor ground speed when turning, leaving enough clearance so that the Road Sweeper does not contact obstacles such as buildings, trees, or fences.
3. Select a safe ground travel speed when transporting from one area to another. When traveling on roadways, transport in such a way that faster moving vehicles may pass safely.
4. When traveling over rough or hilly terrain, shift tractor to a lower gear.

Safety Information

! DANGER

Do not engage tractor PTO while hooking-up and unhooking the driveline or while someone is standing near the driveline. A person’s body and/or clothing can become entangled in the driveline resulting in serious injury or death.

! DANGER

Road Sweeper have the ability to discharge objects at high speeds if guards and safety shields are not in place and closed.

! DANGER

Gearbox and driveline shields must be secured in place when operating the Mowers to avoid injury or death from entanglement in rotating drivelines.

! DANGER

Do not operate a broken or bent driveline. Such a driveline can brake apart while rotating at high speeds causing serious injury or death. Always remove Mowers from service until damaged driveline is repaired or replaced.

! DANGER

Never carry a person on the Road Sweeper A rider can fall or become entangled in the machine causing serious injury or death.

Tractor Shut Down Procedure

It is essential that the tractor be shut down as noted below before making any inspections, maintenance and/or repairs to the tractor and/or Road Sweeper

! DANGER

Do not operate and/or travel across steep inclines where a tractor can roll-over resulting in serious injury or death. Consult your tractor's manual for acceptable inclines the tractor is capable of traveling across.

! DANGER

Do not use Mowers to lift or carry objects. Lifting and/or carrying objects can result in damage to the Road Sweeper, serious bodily injury, or death.

! DANGER

Do not use Road Sweeper as a working platform. The Road Sweeper is not properly designed or guarded for this. Using the Mowers as a working platform can cause serious injury or death.

! WARNING

Always disengage PTO, engage parking brake, shut tractor engine off, remove switch key, and wait for blades to come a complete stop before dismounting from tractor.

! CAUTION

Do not over speed PTO or machine damage may result. This Mowers is designed to be used only with a tractor having a 540 RPM rear PTO.

Working Instructions

1. Clear area to be worked of objects and debris that might be picked up and thrown by the Road Sweeper blades.
Do not use Road Sweeper on stony ground.
2. Make the following machine checks before operating the Road Sweeper .
 - All hook-up pins should be secured.
 - All shields should be in place and secured.
 - All bolts and lock nuts should be present and tight.
 - Make sure the blades are not be broken or loose.

Operating Instructions

Proper servicing and adjustments are the key to the long life of any machine. With careful and systematic inspection of the Road Sweeper, costly maintenance, time, and repair can be avoided.

!

Before beginning to work, the following inspection and checks should be performed:

1. Check oil level in gearbox. Refer to "Gearbox Lubrication" on page 19.
2. Check that all plugs in gearbox have been replaced and tightened properly.
3. Be sure all Road Sweeper, bolts, and lock nuts are tight.
4. Be certain all guards and shields are in place and secure.
5. Grease driveline shaft and all other grease fittings.
6. Clear area to be worked of rocks, branches, and other foreign objects. Do not use Road Sweeper on stony ground.
7. Lower Mowers to ground. Set tractor throttle at approximately 1/4 open. Engage PTO to start blades rotating.
8. Operate with 540 rpm PTO tractor. At first begin working at a slow forward speed and shift up until the desired speed is achieved maintaining 540 rpm PTO.
9. After working the first 50 feet, stop and check to see that the Road Sweeper is adjusted properly.
10. Do not make sharp turns or attempt to back up while Road Sweeper is on the ground.
11. Never work close to or on steep slopes.
12. Do not engage PTO with Road Sweeper in the fully raised position. Do not engage PTO at full throttle. Do not lift Road Sweeper with PTO engage.
13. Do not allow anyone including yourself near the Road Sweeper when it is operating.
14. Periodically check for foreign objects wrapped around the rotor shaft and remove them after disengaging PTO, turning off tractor, and removing ignition key.

General Operating Instructions

Now that you have familiarized yourself with the Operator's Manual, completed the Operators Checklist, properly attached your Road Sweeper to your tractor, made the right offset or center adjustments, and preset your Crushing height,

It's now time to do a running operational safety check. If at any time during this safety check you detect a malfunction in either the Road Sweeper or tractor shut the tractor off immediately, remove the key, and make necessary repairs or adjustments before continuing on.

Make sure the tractor's park brake is engaged, the tractor's PTO is disengaged, and the Road Sweeper is resting on the ground. Start the tractor and then back the tractor throttle off till the engine is at low idle. With the tractor's rear hydraulic lift control lever, raise the Road Sweeper to transport position making sure that the PTO shaft is not in a bind and does not come in contact with the Road Sweeper frame. Lower the unit to Crushing position and, with the tractor still at low idle, engage the PTO. If everything is running smoothly at this point increase the engine rpm until the tractor's engine reaches full PTO operating speed which will be 540 rpm. Slowly raise the cutter to transport height to make sure the driveline does not bind or chatter. Then return the engine to low idle, disengage PTO, and position the adjustable stops on the tractor's hydraulic lift lever control console so the cutter can be consistently returned to the same Crushing and transport height.

You should now be ready to move to the Crushing site to begin working. You should have inspected and should only be sweeping in an area you are familiar with which is relatively free of debris and unseen objects. Never assume an area is clear. In the event you do strike an object, stop the tractor and Road Sweeper immediately to inspect the rotor and make any necessary repairs before resuming operation. It pays to inspect a new area and to develop a plan before you cut.

Normal working speed will be between 2-5 mph and you will need to maintain tractor PTO speed to produce a clean sweeping so make a tractor gear and range selection that

Now you're prepared and well briefed so let's begin sweeping. Reduce the tractor's engine rpm, make sure the Road Sweeper is on the ground and in Sweeping position, engage the PTO, raise the engine rpm to the appropriate PTO speed, and begin working. Operators must plan ahead and choose a Sweeping route that allows safe turns. Try increasing or decreasing ground speed to determine the effect on quality of Sweep With a little practice you will be pleased with what you and your MATENG Road Sweeper can do.

Storage

It is good practice to clean off any dirt and grease that may have accumulated on the Mowers and to inspect and make necessary repairs before parking the unit at the end of the working season and for long periods. This will help ensure that the Mowers will be ready for use the next time you hook-up to it.

! DANGER

Always disconnect main driveline from tractor PTO and secure Mowers in the up position with solid supports before servicing underside of the Mowers .

1. Remove any dirt and grease that may have accumulated on the Mowers and moving parts Scrape off compacted dirt from under the hood and then wash the surface thoroughly with a garden hose.
2. Check rotor blade and blade bolts for wear and replace if necessary. See “**Rotor blade Replacement**” on page 17.
3. Inspect Mowers for loose, damaged, or worn parts and adjust or replace as needed.
4. Repaint parts where paint is worn or scratched to prevent rust. Ask your dealer for MATENG aerosol touch-up paint It are also available in touch-up bottles with brush, quarts, and gallon sizes by adding TU, QT, or GL to the end of the aerosol part number.
5. Replace all damaged or missing labels.
6. A light coat of oil or grease may also be applied to areas where paint has worn off to minimize oxidation.
7. Lubricate as noted under “**Lubrication Points**” on page 19.
8. Store equipment on a level surface in a clean, dry place. Inside storage will reduce maintenance and make for a longer mower life. Position the unit on a flat surface with jack stands lowered to a suitable 3-Point height. Ensure that the main frame is stable.
9. Store driveline end off the ground.



DETAILS



TECHNICAL DATA	<i>SWLT140</i>	<i>SWLT190</i>	<i>SWLT220</i>
Total width	1583mm	2040mm	2380mm
Working width	1428mm	1882mm	2200mm
Mechanical angling	25°	25°	25°
Weight	185kgs	205kgs	235kgs
Brush diameter	520mm		
Drive Type	Chain driven		

www.mateng.com

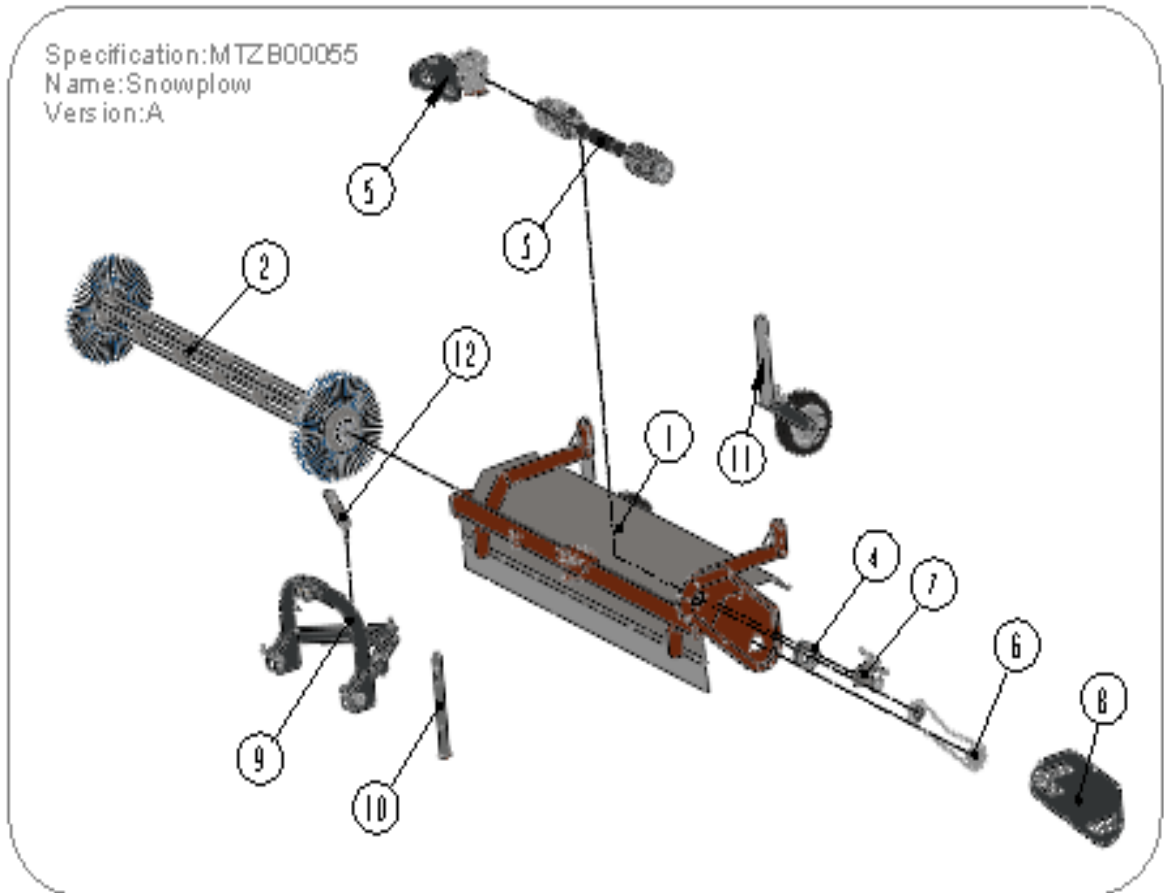

POS.	COD.	Specification	Description	221/Qty	100/Qty	141/Qty
1	2060104883	R09001A01000-000	Hood assembly	1	-	-
1	2060104927	R09002A01000-000	Hood assembly	-	1	-
1	2060104928	R09003A01000-000	Hood assembly	-	-	1
2	2060104884	R09001A02000-000	Sweeping Roller Assembly	1	-	-
2	2060104929	R09002A02000-000	Sweeping Roller Assembly	-	1	-
2	2060104930	R09003A02000-000	Sweeping Roller Assembly	-	-	1
3	2060104887	R09001A08000-000	Drive shaft assembly	1	-	-
3	2060104963	R09002A08000-000	Drive shaft assembly	-	1	-
3	2060104964	R09003A08000-000	Drive shaft assembly	-	-	1
4	2060104885	R09001A04000-000	Left bearing seat assembly	1	1	1
5	2060104886	R09001A07000-000	Gearbox mounting assembly	1	1	1
6	2060104888	R09001A09000-000	Side drive assembly	1	1	1
7	2060104889	R09001A10000-000	Tighting Assembly	1	1	1
8	2060104895	R09001A11000-000	Side Belt Wheel Cover Assembly	1	1	1
9	2060104890	R09001A12000-000	Suspension Assembly	1	1	1
10	2060104891	R09001A16000-000	Supporting Assembly	1	1	1
11	2060104892	R09001A21000-000	Tyre mounting assembly	2	2	2
12	2060104893	R09001A29000-000	Manual lever assembly	1	1	1

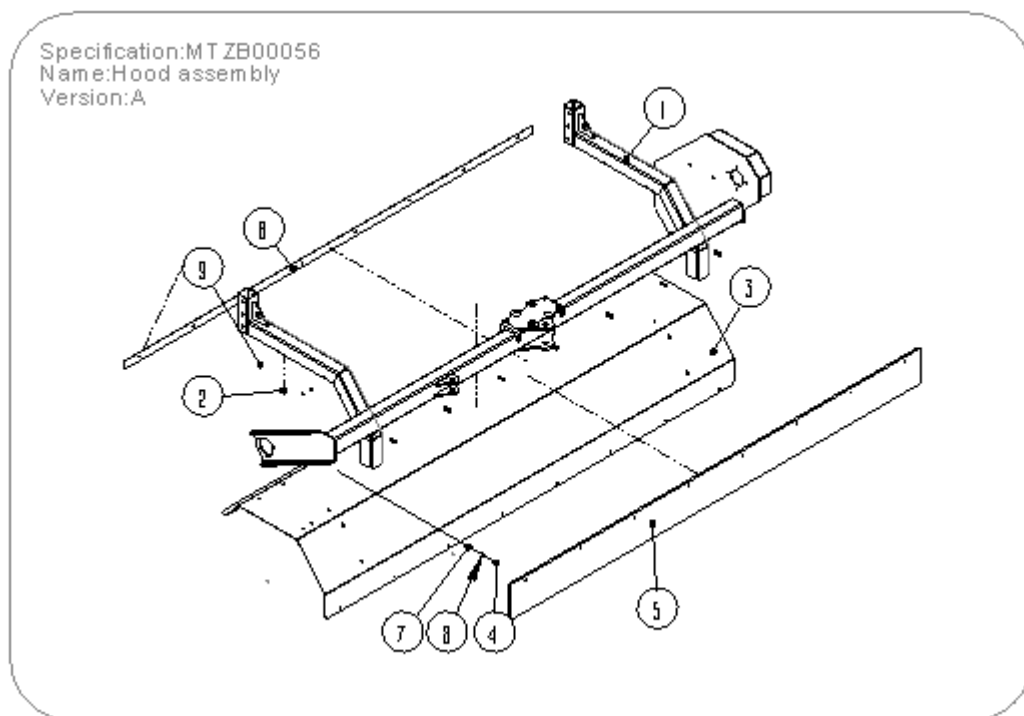

POS.	COD.	Specification	Description	220/Qty	190/Qty	140/Qty
1	2020002056	R09001A01100-000	Hood welding fittings	1	-	-
	2020002054	R09002A01100-000	Hood welding fittings	-	1	-
	2020002055	R09003A01100-000	Hood welding fittings	-	-	1
2	3040100021	GB/T5783-M8×16-8.8-EP•Zn	Full-thread hexagon bolts	8	8	8
	2000104493	R09001A01000-001	Hood plate	1	-	-
	2000104490	R09002A01000-001	Hood plate	-	1	-
	2000104492	R09003A01000-001	Hood plate	-	-	1
3	3050500003	GB/T889.1-M8-8-EP•Zn	Locknut	8	7	5
	3210600102	R09001A01000-002	Rubber sheet for hood	1	-	-
	3210600101	R09002A01000-002	Rubber sheet for hood	-	1	-
	3210600100	R09003A01000-002	Rubber sheet for hood	-	-	1
4	2000001047	R09001A01000-003	Rubber sheet press for hood	1	-	-
	2000001043	R09002A01000-003	Rubber sheet press for hood	-	1	-
	2000001046	R09003A01000-003	Rubber sheet press for hood	-	-	1
5	3040100024	GB/T5783-M8×25-8.8-EP•Zn	Full-thread hexagon bolts	8	7	5
	3080500007	GB/T93-8-EP•Zn	Spring washer	16	15	13
	3050100023	GB13681-M6-5-N	Welding nut	3	3	3

Section 5 : Part List

Page No.3

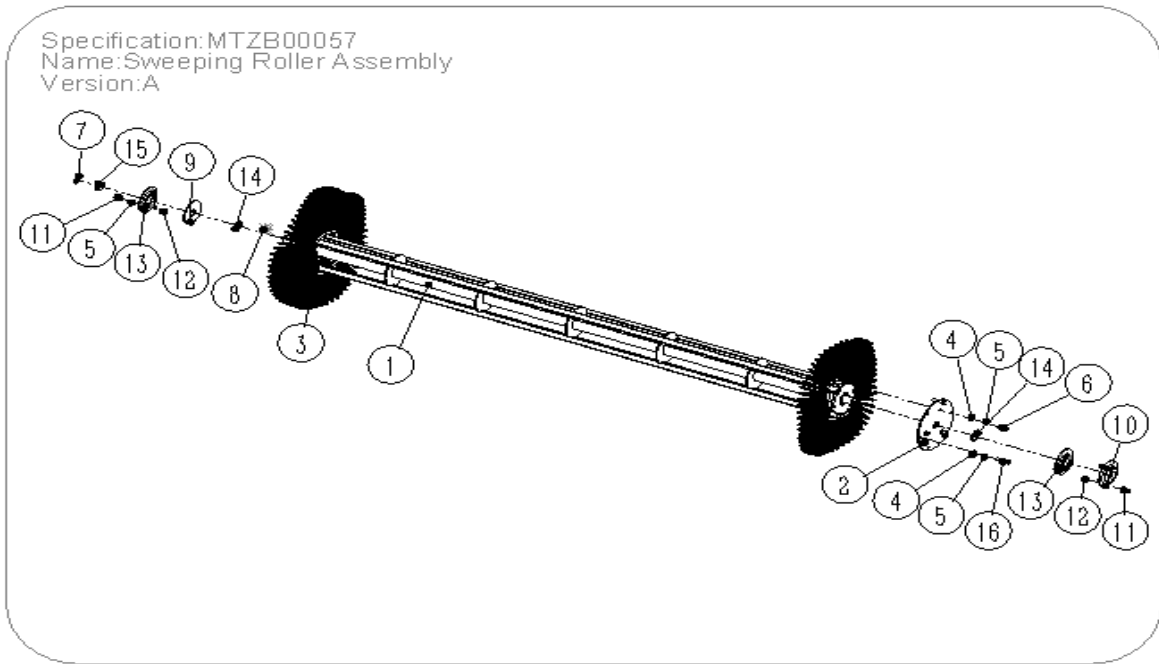

POS.	COD.	Specification	Description	220/Qty	190/Qty	140/Qty
1	2020001829	R09001A02100-000	Sweeping roll welding	1	-	-
	2020001828	R09002A02100-000	Sweeping roll welding	-	1	-
	2020001827	R09003A02100-000	Sweeping roll welding	-	-	1
2	2000000880	R09001A02000-002	Installation flange surface	1	1	1
3	3210400012	R09001A02000-003	Sweeping roller	39	33	25
4	3080100006	GB/T95-10-EP•Zn	Plain washer	6	6	6
5	3080500008	GB/T93-10-EP•Zn	Spring washer	9	9	9
6	3040100045	GB/T5783-M10×30-8.8-EP•Zn	Full-thread hexagon bolts	3	3	3
7	3080700020	GB/T894-30-A	Retaining rings for shaft	1	1	1
8	3090100021	GB/T1096-A8×7×28-EP•Zn	Square and rectangular keys	1	1	1
9	2000000824	R09001A02000-004	Scavenger shaft retaining ring	1	1	1
10	2000000391	R09001A02000-005	Dust-proof cover at axle end	1	1	1
11	3040100043	GB/T5783-M10×25-8.8-EP•Zn	Full-thread hexagon bolts	6	6	6
12	3050500004	GB/T889.1-M10-8-EP•Zn	Locknut	6	6	6
13	3100700004	GB/T7810-SBPF 206	Outer Spherical Ball Bearing with Seat	2	2	2
14	2000000826	R09001A02000-006	Bearing spacer	2	2	2
15	2010004821	R09001A02000-007	Bearing bushing	1	1	1
16	3040100048	GB/T5783-M10×45-8.8-EP•Zn	Full-thread hexagon bolts	3	3	3

Page NO.4

Specification:MTZB00069
Name:Drive shaft assembly
Version:A

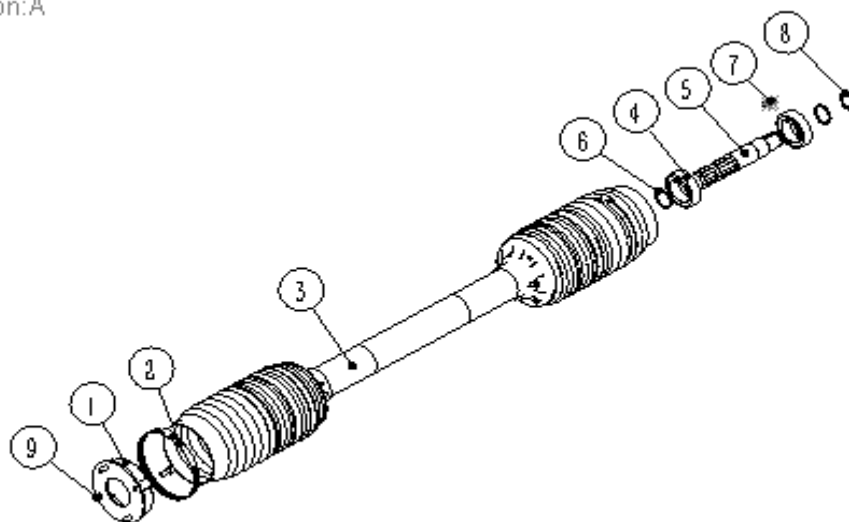

POS.	COD.	Specification	Description	220.Qty	190.Qty	140.Qty
1	2020001743	R09001A08100-000	Welding fittings of sheath connection cover	1	1	1
2	3140600003	QJ177.16A-140-118-ES	Hose clamp	2	2	2
3	3160200603	T4S-BN-P-4S.0507-4S.0507*850	Drive shaft	1	-	-
	3160200604	T4S-BN-P-4S.0507-4S.0507*700	Drive shaft	-	1	-
	3160200605	T4S-BN-0W-4S.0507-4S.0507*525	Drive shaft	-	-	1
4	3100100070	GB/T276-6207-2R S	Deep groove ball bearing	2	2	2
5	3150200098	R09001A08000-001	Axle	1	1	1
6	3080700023	GB/T894-35-A	Retaining rings for shaft	2	2	2
7	3090100021	GB/T1096-A8×7×28-EP•Zn	Square and rectangular keys	1	1	1
8	3080700020	GB/T894-30-A	Retaining rings for shaft	1	1	1
9	3060100026	GB/T70.1-M8×20-8.8-EP•Zn	Hexagon socket head cap screws	4	4	4

Specification: R09001A04000-000
 Name: Left bearing seat assembly
 Version: A

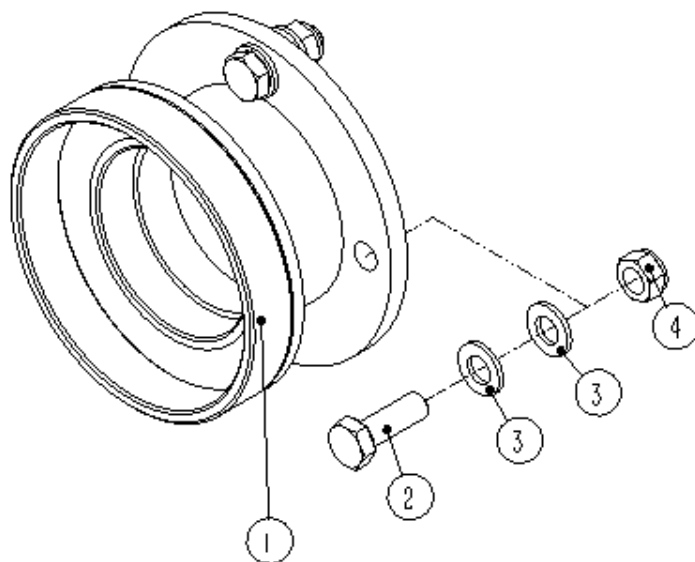

POS.	COD.	Specification	Description	Qty
1	2020001742	R09001A04100-000	Welded joint of bearing seat	1
2	3040100045	GB/T5783-M10×30-8.8-EP•Zn	Full-thread hexagon bolts	4
3	3080100006	GB/T95-10-EP•Zn	Plain washer	8
4	3050500004	GB/T889.1-M10-8-EP•Zn	Locknut	4

Section 5 : Part List

Page No.6

Specification:R09001A07000-000
 Name:Gearbox mounting assembly
 Version:A

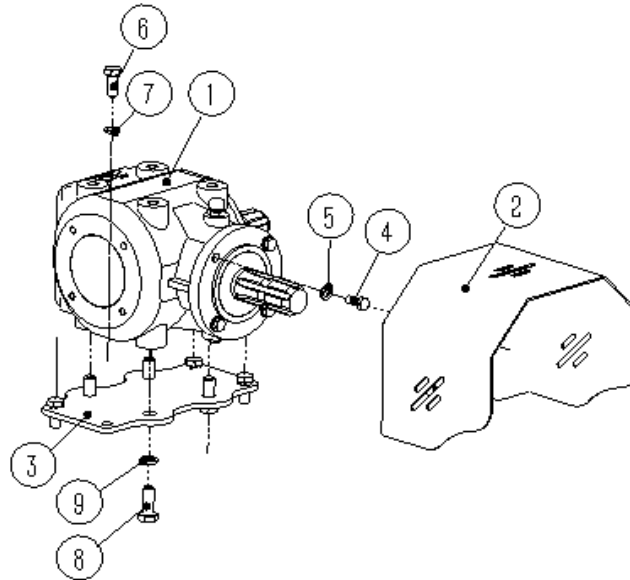

POS.	COD.	Specification	Description	Qty
1	3160100096	XH30-300Z.04WW	Gear box	1
2	2000000625	R09001A07000-001	Protective shield	1
3	2000000850	R09001A07000-002	Gearbox mounting plate	1
4	3040100022	GB/T5783-M8×20-8.8-EP•Zn	Full-thread hexagon bolts	4
5	3080100004	GB/T95-8-EP•Zn	Plain washer	4
6	3040100043	GB/T5783-M10×25-8.8-EP•Zn	Full-thread hexagon bolts	4
7	3080500008	GB/T93-10-EP•Zn	Spring washer	4
8	3040100067	GB/T5783-M12×30-8.8-EP•Zn	Full-thread hexagon bolts	4
9	3080500009	GB/T93-12-EP•Zn	Spring washer	4

Page No.7

Specification: R09001A09000-000

Name: Side drive assembly

Version: A

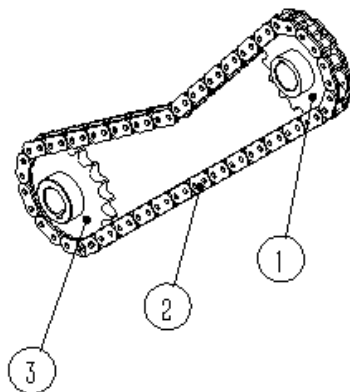

POS.	COD.	Specification	Description	Qty
1	3160700019	Z17-12A	Chain wheel	1
2	3160800013	GB/T1243-12A-1×67	Roller chain	1
3	3160700018	Z19-12A	Chain wheel	1

Specification:R09001A10000-000
Name:Tighting Assembly
Version:A

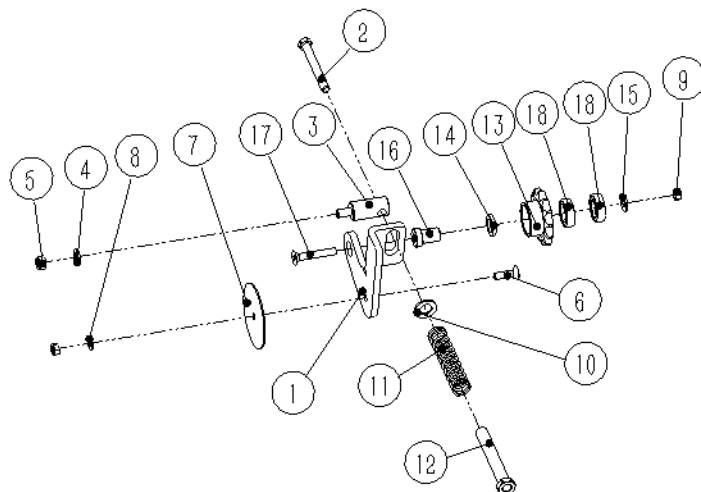

POS.	COD.	Specification	Description	Qty
1	2000001088	R09001A 10000-001	Tensioning plate	1
2	3040100082	GB/T5783-M12×100-8.8-EP•Zn	Full-thread hexagon bolts	1
3	2010000622	R09001A 10000-002	Tightening shaft	1
4	3080100007	GB/T95-12-EP•Zn	Plain washer	1
5	3050500007	GB/T889.1-M12-8-EP•Zn	Locknut	1
6	3060200035	GB/T70.3-M10×35-8.8-EP•Zn	HSCS-Countersunk	1
7	2000000823	R09001A 10000-003	Backing plate	1
8	3080100006	GB/T95-10-EP•Zn	Plain washer	1
9	3050500004	GB/T889.1-M10-8-EP•Zn	Locknut	2
10	3080100010	GB/T95-18-EP•Zn	Plain washer	1
11	3110200021	YI -3×31×3×125×11-R-65Mn-EP•Zn	Pressure spring	1
12	3150200037	R09001A 10000-004	Axle	1
13	3160700020	Z13-12A	Chain wheel	1
14	2010000756	R09001A 10000-005	Bearing spacer	1
15	2000000825	R09001A 10000-006	Bearing washer	1
16	2010000623	R09001A 10000-007	Fixed axle of tightening wheel	1
17	3060200041	GB/T70.3-M10×65-8.8-EP•Zn	HSCS-Countersunk	1
18	3100100018	GB/T276-6004-2RS	Deep groove ball bearing	2

Section 5 : Part List

Page No.9

Specification: R09001A11000-000
 Name: Side Belt Wheel Cover Assembly
 Version: A

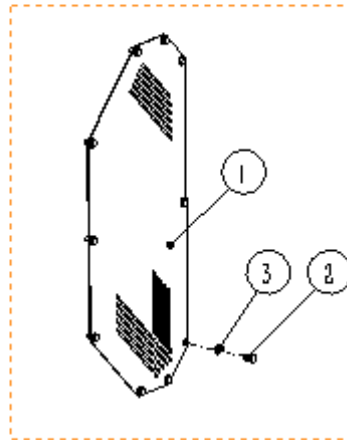

POS.	COD.	Specification	Description	Qty
1	2000000849	R09001A11000-001	Belt wheel cover panel	1
2	3040100021	GB/T5783-M8×16-8.8-EP•Zn	Full-thread hexagon bolts	10
3	3080100004	GB/T95-8-EP•Zn	Plain washer	10

Section 5: Part List

Page No.10

Specification: R09001A12000-000
 Name: Suspension Assembly
 Version: A

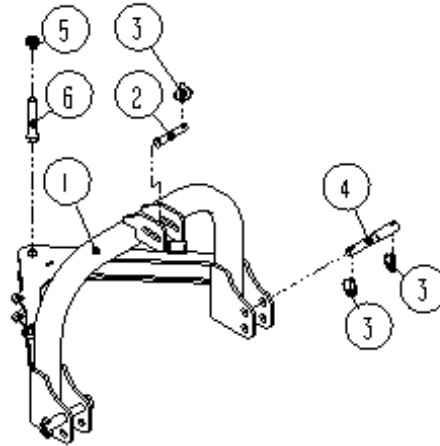

POS.	COD.	Specification	Description	Qty
1	2020001739	R09001A12100-000	Suspension welded joint	1
2	3120500009	MT95003	Pin	1
3	3120400007	GB/T4329-12-EP•Zn	Pin	5
4	3120500008	MT95005	Pin	2
5	3050500011	GB/T889.1-M20-8-EP•Zn	Locknut	1
6	3040300075	GB/T5782-M20×120-8.8-EP•Zn	Hexagon head bolts	1

Section 5 : parts list

Page No.11

Specification:R09001A16000-000
 Name:Supporting Assembly
 Version:A

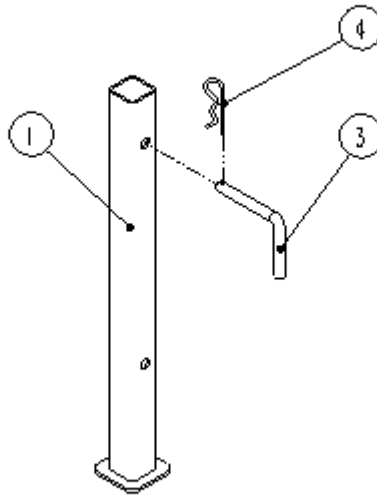

POS.	COD.	Specification	Description	Qty
1	2020001705	R09001A16100-000	Butt welded joint	1
2	2010000017	G01001A16000-001	Raker pin	1
3	3120400008	Din11024-4-EP•Zn	R Pin	1

Specification:R 09001 A21 000-000
Name:Tyre mounting assembly
Version:A

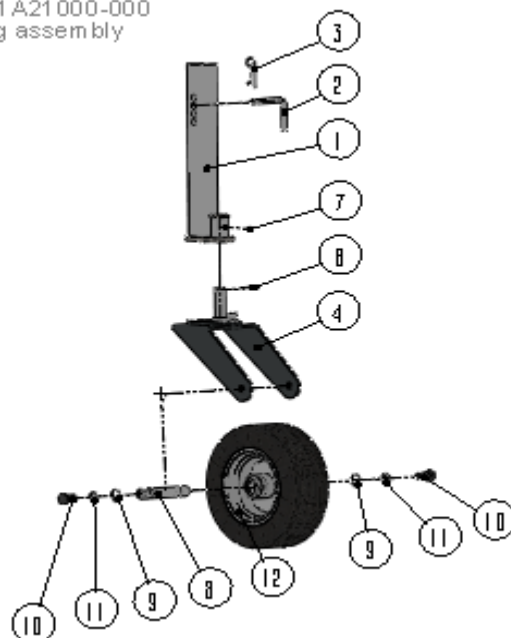

POS.	COD.	Specification	Description	Qty
1	2020001741	R09001A21100-000	Welding fittings of adjusting arm	1
2	2010000017	G01001A16000-001	Raker pin	1
3	3120400008	Din11024-4-EP•Zn	R Pin	1
4	2020001740	R09001A21200-000	Fork welded joint	1
5	3080100013	GB/T 95-24-EP•Zn	Plain washer	1
6	3120100095	GB/T91-4×40	Split pin	1
7	3170400004	JB/T7940.1-M10×1	Grease nipple	1
8	2010000621	R09001A21000-001	Tire shaft	1
9	3080700016	GB/T894-25-A	Retaining rings for shaft	2
10	3040100104	GB/T5783-M16×30-8.8-EP•Zn	Full-thread hexagon bolts	2
11	3080500011	GB/T 93-16-EP•Zn	Spring washer	2
12	3140200036	13×5-6	Vehicle wheel	1

Specification:R09001A29000-000
Name:Manual leaver assembly
Version:A

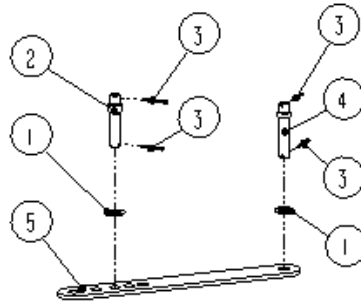

POS.	COD.	Specification	Description	Qty
1	3080100011	GB/T95-20-EP•Zn	Plain washer	2
2	2010000619	R09001A29000-001	Cylinder Short Pin Shaft	1
3	3120100095	GB/T91-4×40	Split pin	4
4	2010000620	R09001A29000-002	Cylinder Long Pin Shaft	1
5	2000000866	R09001A29000-003	Manual lever	1

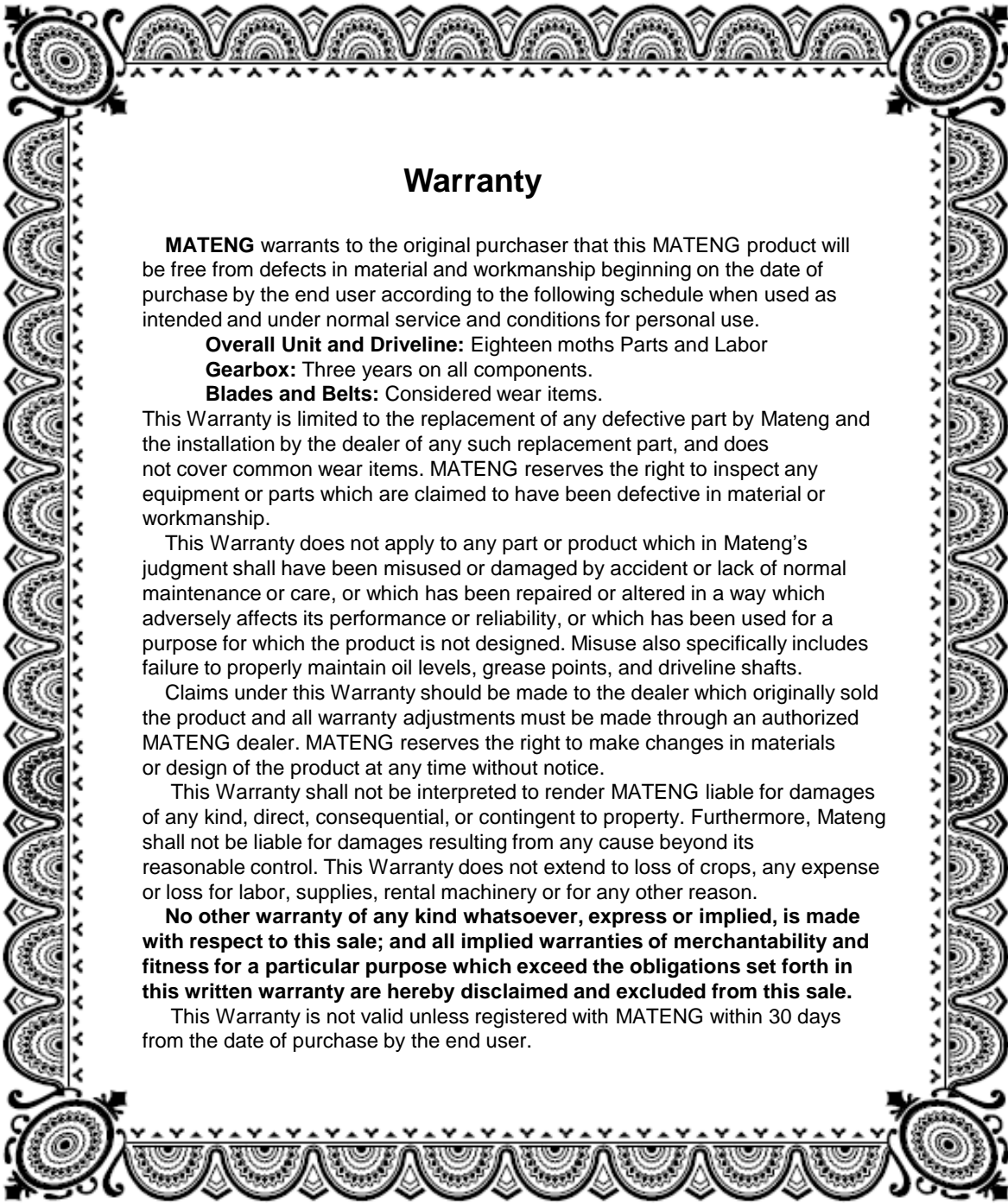

Warranty

MATENG warrants to the original purchaser that this MATENG product will be free from defects in material and workmanship beginning on the date of purchase by the end user according to the following schedule when used as intended and under normal service and conditions for personal use.

Overall Unit and Driveline: Eighteen months Parts and Labor

Gearbox: Three years on all components.

Blades and Belts: Considered wear items.

This Warranty is limited to the replacement of any defective part by Mateng and the installation by the dealer of any such replacement part, and does not cover common wear items. MATENG reserves the right to inspect any equipment or parts which are claimed to have been defective in material or workmanship.

This Warranty does not apply to any part or product which in Mateng's judgment shall have been misused or damaged by accident or lack of normal maintenance or care, or which has been repaired or altered in a way which adversely affects its performance or reliability, or which has been used for a purpose for which the product is not designed. Misuse also specifically includes failure to properly maintain oil levels, grease points, and driveline shafts.

Claims under this Warranty should be made to the dealer which originally sold the product and all warranty adjustments must be made through an authorized MATENG dealer. MATENG reserves the right to make changes in materials or design of the product at any time without notice.

This Warranty shall not be interpreted to render MATENG liable for damages of any kind, direct, consequential, or contingent to property. Furthermore, Mateng shall not be liable for damages resulting from any cause beyond its reasonable control. This Warranty does not extend to loss of crops, any expense or loss for labor, supplies, rental machinery or for any other reason.

No other warranty of any kind whatsoever, express or implied, is made with respect to this sale; and all implied warranties of merchantability and fitness for a particular purpose which exceed the obligations set forth in this written warranty are hereby disclaimed and excluded from this sale.

This Warranty is not valid unless registered with MATENG within 30 days from the date of purchase by the end user.

Model Number _____ Serial Number _____

MATENG®

Changzhou Mateng machinery Co., Ltd

10# Chuangsheng Road, LuoYang Industrial Park,
Wujin District, Changzhou City ,Jiangsu Province ,P.R.of China
213104

Tel: 0086-519-8823 8398·

Fax: 0086-519-8823 8397

E-mail address

mateng@mateng.com
