

# QuantStudio™ 5 Real-Time PCR Instrument (for Human Identification)

## USER GUIDE

Installation, maintenance, and administration

for use with:

**HID Real-Time PCR Analysis Software v1.3**

Publication Number MAN0017162

Revision A.0



**Manufacturer:** Life Technologies Holdings Pte Ltd | Block 33 | Marsiling Industrial Estate Road 3 | #07-06, Singapore 739256

The information in this guide is subject to change without notice.

**DISCLAIMER:** TO THE EXTENT ALLOWED BY LAW, LIFE TECHNOLOGIES AND/OR ITS AFFILIATE(S) WILL NOT BE LIABLE FOR SPECIAL, INCIDENTAL, INDIRECT, PUNITIVE, MULTIPLE, OR CONSEQUENTIAL DAMAGES IN CONNECTION WITH OR ARISING FROM THIS DOCUMENT, INCLUDING YOUR USE OF IT.

**Revision history:** Pub. No. MAN0017162

Revision	Date	Description
A.0	15 June 2017	New document for Human Identification workflows using instrument firmware v1.3.1.

**Important Licensing Information:** This product may be covered by one or more Limited Use Label Licenses. By use of this product, you accept the terms and conditions of all applicable Limited Use Label Licenses.

**Trademarks:** All trademarks are the property of Thermo Fisher Scientific and its subsidiaries unless otherwise specified. Microsoft and Windows are trademarks of Microsoft Corporation. Pentium is a trademark of Intel Corporation.

©2017 Thermo Fisher Scientific Inc. All rights reserved.

# Contents

■	<b>CHAPTER 1</b>	<b>Product information</b>	7
		Instrument overview	7
		Installation, verification, and calibration	8
		Instrument filters and supported dyes	9
		System dyes	9
		Custom dyes	10
		Parts of the instrument	10
		Parts of the home screen	11
		Comparison of features in desktop software and the instrument	13
■	<b>CHAPTER 2</b>	<b>Install the instrument</b>	14
		Workflow: Install the instrument	14
		Before you begin installation	14
		Unpack and install the instrument	15
		Power on and follow the startup wizard	15
		Instrument and computer connections	16
		Computer-to-instrument configuration	17
		Firewall ports that must be open	17
■	<b>CHAPTER 3</b>	<b>General procedures to use the instrument</b>	18
		Precautions for use	18
		Power on the instrument	19
		Power off the instrument	19
		Sign in	20
		Sign out	20
		Load and unload plate in the instrument	21
		View real-time data and plots on the instrument touchscreen	22
		Adjust the display of real-time plots on the instrument touchscreen	22
		Transfer EDS files from the instrument home screen	22

- **CHAPTER 4** Configure the instrument and manage instrument profiles ..... 23
  - Initial start up ..... 23
  - Overview of instrument settings *(Administrator)* ..... 24
  - Overview of instrument settings *(Standard or Guest)* ..... 26
  - Manage instrument profiles ..... 27
    - Instrument profiles and signed-in users ..... 27
    - Create an administrator instrument profile during initial start-up ..... 27
    - Create a new instrument profile ..... 28
    - Edit an instrument profile ..... 28
    - Manage all instrument profiles ..... 28
  - Require instrument profile sign-in ..... 29
  - Manage the sign out timer ..... 29
  - Manage the instrument name ..... 29
  - Enable sleep mode ..... 30
  - Set the idling temperature for the heated cover ..... 30
  - Set the date and time ..... 30
  - Restore factory defaults ..... 31
  - Enable **Remote Monitoring Service** ..... 31
  - Update instrument software ..... 32
  
- **CHAPTER 5** Calibrate and verify instrument performance ..... 33
  - Calibration and verification schedule ..... 34
  - Calibration descriptions ..... 35
  - View calibration status and set reminders in the instrument ..... 36
  - Perform ROI/uniformity, background, and dye calibrations ..... 36
    - Workflow: Calibration ..... 36
    - Prepare a calibration plate ..... 37
    - Perform calibrations ..... 38
    - View calibration images ..... 39
    - Identify contamination ..... 40
    - Create a background plate *(optional)* ..... 40

Calibrate dyes for HID-validated workflows .....	41
Workflow: Calibrate dyes for HID-validated workflows .....	41
Prepare a calibration plate for HID-validated workflows .....	41
Add custom dyes to the instrument for HID-validated workflows .....	42
Perform a custom dye calibration for HID-validated workflows .....	42
Perform instrument verification using RNase P plates .....	44
Instrument verification description .....	44
RNase P instrument verification plate .....	45
Performance specifications pass criteria .....	45
Prepare an RNase P plate .....	46
Perform RNase P verification .....	47
<b>■ CHAPTER 6 Maintain the instrument .....</b>	<b>48</b>
Backup or restore the instrument .....	48
Decontaminate the sample block .....	49
Materials required .....	49
Clean the sample block .....	49
Detailed procedures for cleaning the sample block .....	51
Replace the instrument fuses .....	52
Materials required .....	52
Replace the fuses .....	52
Store, move, or ship the instrument .....	53
Prepare the instrument to store, move, or ship .....	53
Move the instrument .....	53
Return the instrument for service .....	54
<b>■ APPENDIX A Troubleshooting .....</b>	<b>55</b>
Instrument troubleshooting .....	55
Troubleshoot calibration failure .....	56
Troubleshoot verification failure .....	57
<b>■ APPENDIX B Parts and materials .....</b>	<b>58</b>
Kits, consumables, accessories, and reagents .....	58
Consumables (96-well, 0.2-mL format) .....	59
Accessories .....	60
General-use materials and consumables .....	60

- **APPENDIX C Instrument specification and layout ..... 61**
  - Configured system dimensions ..... 62
  - Instrument and computer connections ..... 63
  - Instrument clearances ..... 64
  - Electrical requirements ..... 64
  - Environmental requirements ..... 65
  
- **APPENDIX D Safety ..... 66**
  - Symbols on this instrument ..... 67
    - Conformity symbols ..... 68
  - Safety alerts on this instrument ..... 69
    - Location of safety labels on the instrument ..... 69
  - Safety information for instruments not manufactured by Thermo Fisher Scientific ..... 70
  - Instrument safety ..... 70
    - General ..... 70
    - Physical injury ..... 71
    - Electrical ..... 72
    - Cleaning and decontamination ..... 72
  - Safety and electromagnetic compatibility (EMC) standards ..... 72
    - Safety compliance ..... 73
    - EMC ..... 73
    - Environmental design ..... 74
  - Chemical safety ..... 74
  - Biological hazard safety ..... 75
  
- Documentation and support ..... 76**
  - Related documentation ..... 76
  - Obtain information from the Help system ..... 76
  - Customer and technical support ..... 76
  - Limited product warranty ..... 76
  
- Index ..... 77**



# Product information

■ Instrument overview .....	7
■ Installation, verification, and calibration .....	8
■ Instrument filters and supported dyes .....	9
■ Parts of the instrument .....	10
■ Parts of the home screen .....	11
■ Comparison of features in desktop software and the instrument .....	13

## Instrument overview

The QuantStudio™ 5 Real-Time PCR Instrument uses fluorescence-based polymerase chain reaction (PCR) reagents to perform:

- Quantitative detection of target nucleic acid sequences (targets).
- Qualitative detection of targets (endpoint analysis, genotyping, and presence/absence).



The instrument is configured with a 96-well 0.2-mL fixed block (6 color de-coupled).

To run experiments using HID assays, the instrument must be integrated with the HID Real-Time PCR Analysis Software v1.3.

## Installation, verification, and calibration

Your HID Support Representative will contact you to schedule the installation. During instrument installation, the service representative will perform the initial instrument verification using an RNase P plate and calibrate the instrument for the versions of ABY™ and JUN™ dye used by HID-validated workflows.

Instruments are factory calibrated, so ROI, uniformity, background, and system dye calibrations are not necessary at installation.

You do have the option to install the instrument yourself. Before first use of the instrument, complete the following tasks:

- Install the instrument (see page 14).
- Verify instrument performance (see page 44).
- Perform custom dye calibrations for ABY™ and JUN™ dyes (see page 41).

After installation, perform regular calibration and verification according to the “Calibration and verification schedule” on page 34.



## Instrument filters and supported dyes

### System dyes

The instrument uses a de-coupled six-color optical filter set that supports the dyes shown in the following table and figure. For more information about the spectral dye calibration kits available for the instrument, contact your HID Support Representative.

Peak filter	Color	Filter wavelength (nm) <sup>[1]</sup>		Factory-calibrated dyes	Example custom dyes
		Excitation	Emission		
x1-m1	Blue	470 ± 15	520 ± 15	FAM™, SYBR™ Green	SYT09
x2-m2	Green	520 ± 10	558 ± 12	VIC™	JOE™, HEX™, TET™ [2]
x3-m3	Yellow	550 ± 10	587 ± 10	NED™, TAMRA™, ABY™ [3]	Cy®3
x4-m4	Orange	580 ± 10	623 ± 14	ROX™, JUN™ [3]	Texas Red™
x5-m5	Red	640 ± 10	682 ± 14	MUSTANG PURPLE™, Cy®5	LIZ™
x6-m6	Deep-Red	662 ± 10	711 ± 12	None [4]	Cy® 5.5

[1] The central wavelengths are the optimized wavelengths.

[2] The HEX™ and TET™ dyes from Thermo Fisher Scientific fall within the emission wavelength range of the system, therefore they can be added and adapted for use on the instrument.

[3] HID-validated workflows use versions of ABY™ and JUN™ dyes that are considered custom dyes.

[4] This filter set currently does not support any dyes supplied by Thermo Fisher Scientific.

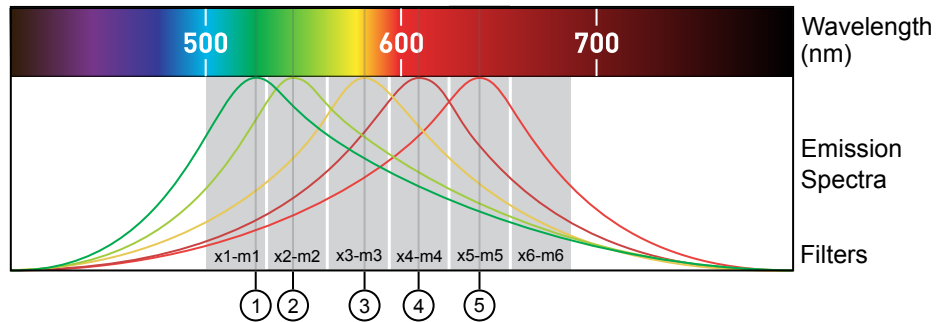

① x1-m1 — FAM™, SYBR™ Green

② x2-m2 — VIC™

③ x3-m3 — ABY™, NED™, Cy®3, TAMRA™

④ x4-m4 — JUN™, ROX™, Texas Red™

⑤ x5-m5 — Cy®5, MUSTANG PURPLE™

## Custom dyes

The instrument can run assays designed with custom dyes. Custom dyes include:

- Dyes that are not supplied by Thermo Fisher Scientific.
- Dyes or versions of dyes that are not factory-calibrated on the instrument.

**Note:** HID-validated workflows use versions of ABY™ and JUN™ dyes that are considered custom dyes for the instrument. To calibrate these ABY™ and JUN™ dyes, see page 41. To calibrate any other custom dye, contact your HID Support Representative.

## Parts of the instrument

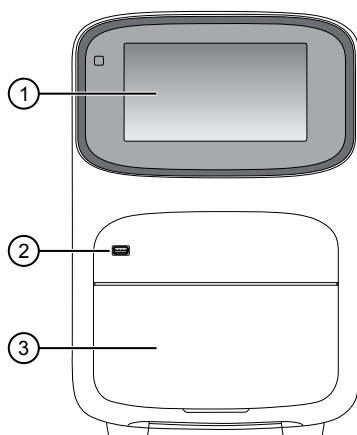

- ① **Touchscreen** – Controls the instrument.
- ② **USB port** – For connection to an external network drive or external data storage device.
- ③ **Instrument drawer** – Contains sample plate.

The instrument includes three additional USB ports on the back of the instrument.

**Note:** The instrument recognizes only one external storage device at a time for data transfer.



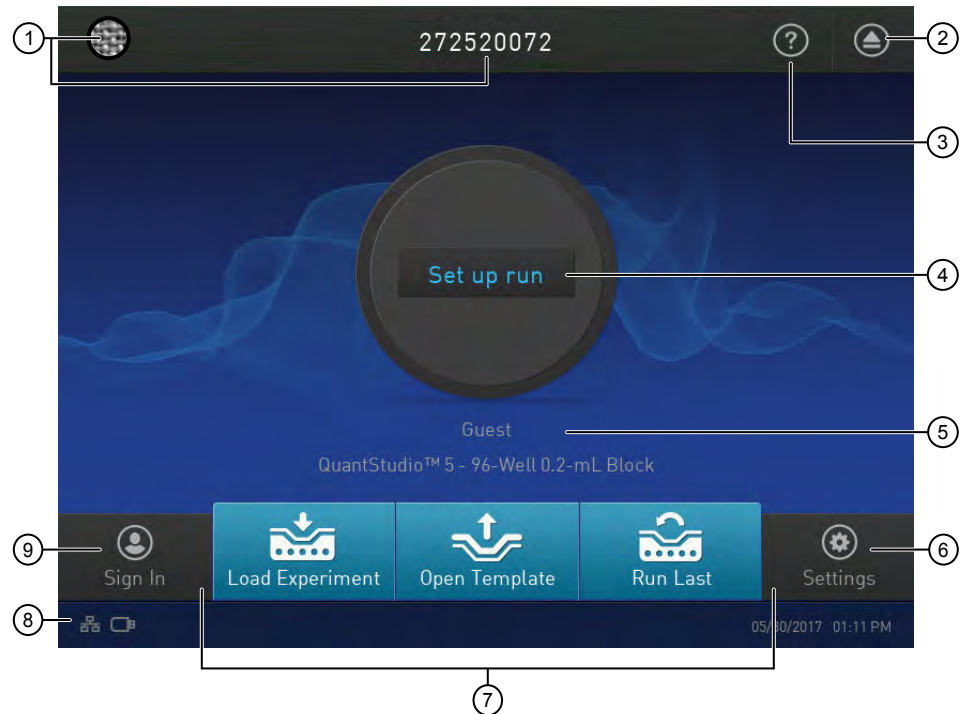

## Parts of the home screen



- ① Avatar and Instrument name
- ② Eject instrument drawer icon
- ③ Help system icon
- ④ Status dial
- ⑤ Instrument profile name; instrument block type
- ⑥ **Settings** button
- ⑦ Access templates buttons (not applicable for HID-validated workflows)
- ⑧ Connectivity icons
- ⑨ **Sign In** (or **My Profile**) button

**Table 1** Parts of the home screen

Element of the home screen	Function
Avatar and Instrument name	Set by the administrator to uniquely identify the instrument.
Eject instrument drawer icon	Touch  to open or close the instrument drawer.
Help icon	Touch  to launch the touchscreen Help system to access step-by-step instructions.
Status dial	<p><b>When the instrument is not in use</b> – Displays <b>Set up run</b>.</p> <p><b>Note:</b> Instrument runs must be set up and started from the desktop software.</p> <p><b>When the instrument is in use</b> – Displays the sample block temperature, the elapsed run time, and the run status.</p> <p><b>Note:</b> Swipe the dial to the left or touch  to access real-time views of the run.</p>
Instrument profile username and block type	<p>Displays the username of a signed-in user and the instrument block type.</p> <p><b>Note:</b> If no user is signed in, the instrument defaults to the <b>Guest</b> profile.</p>

Element of the home screen	Function
<b>Settings</b> button	Touch  <b>Settings</b> to configure, calibrate, or learn about the instrument.
Connectivity icons	<ul style="list-style-type: none"><li>•  - The instrument is connected via a wired configuration.</li><li>•  - A USB drive is plugged into the instrument.</li></ul>
<b>Sign In</b> button ( <b>My Profile</b> button when a user is signed in)	<ul style="list-style-type: none"><li>• Touch  <b>Sign In</b> to sign into an instrument profile.</li><li>• Touch  <b>My Profile</b> to change instrument profile settings.</li></ul>

## Comparison of features in desktop software and the instrument

To run experiments using HID assays, the instrument must be integrated with the HID Real-Time PCR Analysis Software v1.3.

Actions	Desktop software	Instrument
<b>Enter or edit properties</b> <sup>[1]</sup>		
Edit experiment name; enter user name	✓	—
Select instrument, experiment type, chemistry, run mode	✓	—
<b>Edit method</b> <sup>[1]</sup>		
Edit the thermal protocol, reaction volume, optical filter selection	✓	—
<b>Set up plate and well details</b> <sup>[1]</sup>		
Define samples	✓	—
Assign samples to wells	✓	—
Define targets	✓	—
Assign targets to wells	✓	—
<b>Instrument run</b>		
Start an instrument run <sup>[1]</sup>	✓	—
Monitor a run in progress	✓	✓
View time remaining	✓	✓
View real-time plots	—	✓
<b>Run results</b>		
Review run results (analyzed run data)	✓	—
Configure analysis settings	✓	—
<b>Export</b>		
Select export options for run data and run results (analyzed run data)	✓	—
Export run data	✓	✓
Export template settings	✓	—

<sup>[1]</sup> Feature is available in the instrument touchscreen, but it is not validated for the HID assay workflow.

# 2

## Install the instrument

- Workflow: Install the instrument ..... 14
- Before you begin installation ..... 14
- Unpack and install the instrument ..... 15
- Power on and follow the startup wizard ..... 15
- Instrument and computer connections ..... 16
- Computer-to-instrument configuration ..... 17

### Workflow: Install the instrument

Perform all steps in “Before you begin installation” on page 14



“Unpack and install the instrument” on page 15



“Power on and follow the startup wizard” on page 15



“Perform instrument verification using RNase P plates” on page 44



“Calibrate dyes for HID-validated workflows” on page 41

### Before you begin installation

A Thermo Fisher Scientific service representative will contact you to schedule an installation. However, you do have the option to install the instrument yourself.

Before starting the installation:

- Review the site requirements in the *QuantStudio™ 5 Real-Time PCR Instrument Site Preparation Guide (for Human Identification)* (Pub. No. MAN0016701).
- Review the HID-validated computer-to-instrument configuration (page 16).

## Unpack and install the instrument

1. Prepare the installation site as described in the *QuantStudio™ 5 Real-Time PCR Instrument Site Preparation Guide (for Human Identification)* (Pub. No. MAN0016701).
2. Follow the pre-printed instructions on the instrument box to unpack the instrument, accessories, and reference documentation. Save the packing material for future use or recycle it.

The instrument box contains:

- Reference documentation: Welcome note, unpacking and set up instructions card, system documentation insert
- One instrument
- Accessories: power cable, Ethernet cable, USB drive, reaction tube retainer
- Shipping plate

**Note:** Save the shipping plate but do not use it to operate the instrument.

- Spectral calibration plates for HID-validated workflows.

**Note:** Store these plates at  $-20^{\circ}\text{C}$  ( $-15^{\circ}\text{C}$  to  $-25^{\circ}\text{C}$ ).

3. Place the instrument on the bench.
4. Plug the power cable into the power port on the back panel of the instrument, then plug the cable into an electrical receptacle.
5. Connect an Ethernet cable to the Ethernet port on the back panel of the instrument, then connect the cable to the computer.

## Power on and follow the startup wizard

1. Power on the instrument.
2. Follow the startup wizard through the following tasks:
  - Accept the license agreement
  - Configure the instrument date and time.
  - Create an administrator instrument profile

**Note:** You can perform any of the steps above at a later time if you do not have the information needed to complete the startup screens. See page 23.

---

**IMPORTANT!** Before using the instrument for the first time, we recommend that you “Perform instrument verification using RNase P plates” on page 44.

---

## Instrument and computer connections

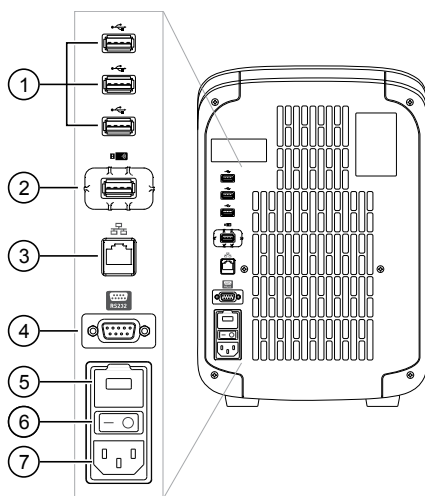

**Figure 1** Instrument back panel

- |   |                                   |
|---|-----------------------------------|
| ① USB ports   | ④ RS232 Port—For service use only |
| ② WiFi USB port—Not applicable  | ⑤ Fuse Cover                      |
| ③ Ethernet Port—RJ45 port for<br>100/1,000 Mbps Ethernet communication<br>with the instrument | ⑥ Power Switch                    |
|   | ⑦ Power Port—100 to 240 VAC       |

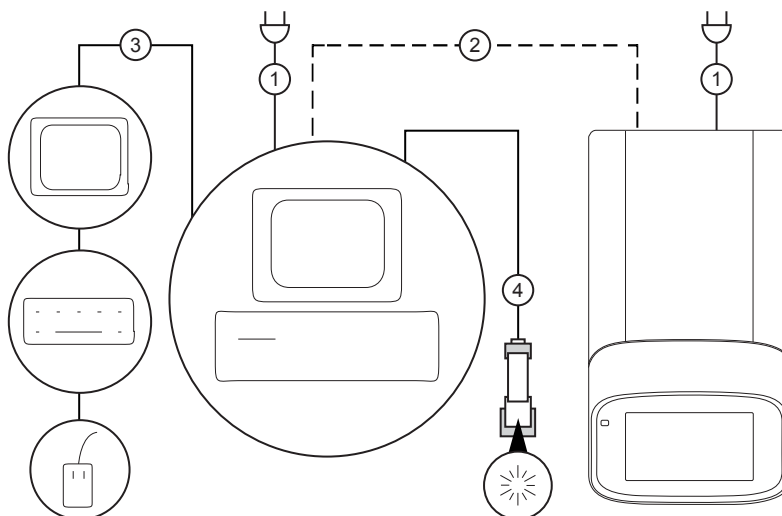

**Figure 2** Instrument-to-computer connections (minitower configuration)

- ① Detachable power supply cord compatible with local power supply receptacle.
- ② Connection between the computer and the instrument.
- ③ Connection between the computer and the monitor, keyboard, and mouse.
- ④ Connection between the computer and the *optional* handheld barcode scanner.



## Computer-to-instrument configuration

**IMPORTANT!** For HID use, the QuantStudio™ 5 Real-Time PCR System has been validated for a direct (computer-to-instrument) configuration. During installation, a Thermo Fisher Scientific service representative can set up only a direct configuration.

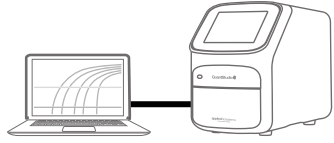
Direct configuration	
<ul style="list-style-type: none"> <li>A computer provided by Thermo Fisher Scientific with the HID Real-Time PCR Analysis Software v1.3</li> </ul>	
<ul style="list-style-type: none"> <li>Computer-to-instrument connection:                             <ul style="list-style-type: none"> <li>Direct, wired connection between the computer and the instrument using an Ethernet cable</li> </ul> </li> </ul>	

### Firewall ports that must be open





Ports	Condition
mDNS, 7000	Instrument-to-computer connection
mDNS, 5353	Instrument discovery

# 3

## General procedures to use the instrument

- Precautions for use ..... 18
- Power on the instrument ..... 19
- Power off the instrument ..... 19
- Sign in ..... 20
- Sign out ..... 20
- Load and unload plate in the instrument ..... 21
- View real-time data and plots on the instrument touchscreen ..... 22
- Transfer EDS files from the instrument home screen ..... 22

### Precautions for use

- 
-  **CAUTION! PHYSICAL INJURY HAZARD.** Do not remove the instrument cover. There are no components inside the instrument that you can safely service yourself. If you suspect a problem, contact technical support.
- 
-  **CAUTION! FIRE HAZARD.** For continued protection against the risk of fire, replace fuses only with listed and certified fuses of the same type and rating as those currently in the instrument.
- 
-  **CAUTION! PHYSICAL INJURY HAZARD.** During instrument operation, the sample block temperature can reach 100°C. Allow it to cool to room temperature before handling.
- 
-  **CAUTION!** Before using a cleaning or decontamination method other than those recommended by Thermo Fisher Scientific, confirm with Thermo Fisher Scientific that the proposed method will not damage the instrument.
- 
-  **CAUTION!** Use flat caps for tubes. Rounded caps can damage the heated cover.
-

## Power on the instrument

To power on the instrument from a powered-off state:

1. Touch anywhere on the touchscreen to determine if the instrument is in sleep mode. If the home screen displays, the instrument is already powered on.
2. If the home screen does not display, power on the instrument by pressing the switch on the rear panel.

If left unattended (for about two hours), the instrument automatically enters sleep mode (enabled by default) to conserve power.

**Note:** To customize the sleep mode setting, touch  **Settings** ▶ **Instrument Settings** ▶ **Sleep Mode**.

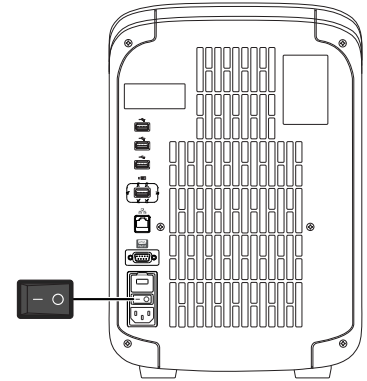

## Power off the instrument

The instrument operates in low-power mode when not in use. However, the instrument can be powered off completely so that the components use no power.

**Note:** To power off the instrument for >1 week, see page 53 .

1. Power off the instrument using the power switch on the back of the instrument.
2. Power off the computer.

## Sign in

Create an instrument profile before signing into the instrument (see “Create a new instrument profile” on page 28).

**Note:** An instrument profile is a user account specifically for the instrument. It is not related to any other user account for the system or software.

In the home screen:

1. Touch  **Sign In**.
2. Touch **Sign In**, then select your username.
3. Enter your PIN, then touch **Enter**.

## Sign out

In the home screen:

1. Touch  **My Profile**.
2. Touch **Sign Out**.

## Load and unload plate in the instrument

---

 **CAUTION!** Use optical flat caps for tubes. Rounded caps can damage the heated cover.

---

1. Load the plate.
  - a. Touch  to eject the instrument drawer.
  - b. Load the plate onto the plate adapter so that:
    - Well A1 of the plate is in the top-left corner of the plate adapter.
    - The barcode faces the front of the instrument.

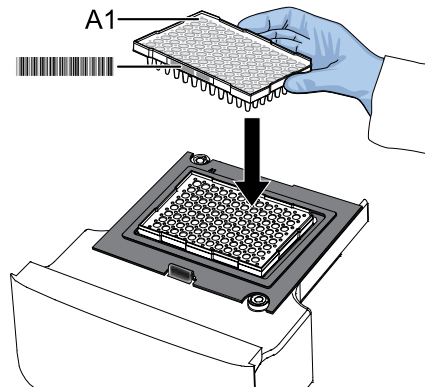



---

**IMPORTANT!** The instrument should be used by trained operators who have been warned of the moving parts hazard.

---

**Note:** Do not remove the black plate adapter before loading a plate or tube strips. If used, tube strips may fit loosely in the adapter, but the heated cover will apply the appropriate pressure to seat the tube strips securely in the adapter.

- c. Touch  to close the instrument drawer.
2. When the run ends, unload the plate.
  - a. Touch  to eject the instrument drawer.
  - b. Remove the plate.
  - c. Touch  to close the instrument drawer.

---

 **CAUTION! PHYSICAL INJURY HAZARD.** During instrument operation, the plate temperature can reach 100°C. Allow it to cool to room temperature before handling.

---

**Note:** If the instrument does not eject the plate, contact Support.



## View real-time data and plots on the instrument touchscreen

In the instrument home screen, during an instrument run:

1. Touch  or swipe left twice.
2. Touch **Well details**.
3. Touch **Samples**, **Targets**, or **Tasks** to select a graphical representation of each selection.
4. Touch **Close** to return to the home screen.

### Adjust the display of real-time plots on the instrument touchscreen

In the instrument home screen, during an instrument run:

1. Touch  or swipe left twice to view real-time data and plots.
2. Touch **Zoom**.
3. Touch  or  to zoom in or out.
4. Touch the arrows to pan left, right, up, or down on the graph.
5. Touch **Close** to return to the default view.

## Transfer EDS files from the instrument home screen

In the instrument home screen, when a run ends:

1. Touch **Transfer File**.
2. Select the data destination for the EDS file.
3. Navigate to and select a folder.
4. Touch **OK**.
5. Touch **Transfer**.

**Note:** Touch  **Settings** ▶ **Run History** to transfer EDS files at any time.



# Configure the instrument and manage instrument profiles

■ Initial start up .....	23
■ Overview of instrument settings (Administrator) .....	24
■ Overview of instrument settings (Standard or Guest) .....	26
■ Manage instrument profiles .....	27
■ Require instrument profile sign-in .....	29
■ Manage the sign out timer .....	29
■ Manage the instrument name .....	29
■ Enable sleep mode .....	30
■ Set the idling temperature for the heated cover .....	30
■ Set the date and time .....	30
■ Restore factory defaults .....	31
■ Enable Remote Monitoring Service .....	31
■ Update instrument software .....	32

## Initial start up

Perform initial start up tasks:

- After initially powering on the instrument (see page 19).
  - After restoring factory defaults (see page 31).
1. Ensure that there is a direct, wired connection between the computer and the instrument using an Ethernet cable (see page 17).
  2. Create an administrator instrument profile (see page 27).
  3. *(Optional)* Manage the instrument name (see page 29).
  4. Set the date and time (see page 30).

## Overview of instrument settings (Administrator)

Touch  **Settings** in the home screen to configure the instrument settings as needed. Access to most settings are restricted to administrator instrument profiles.

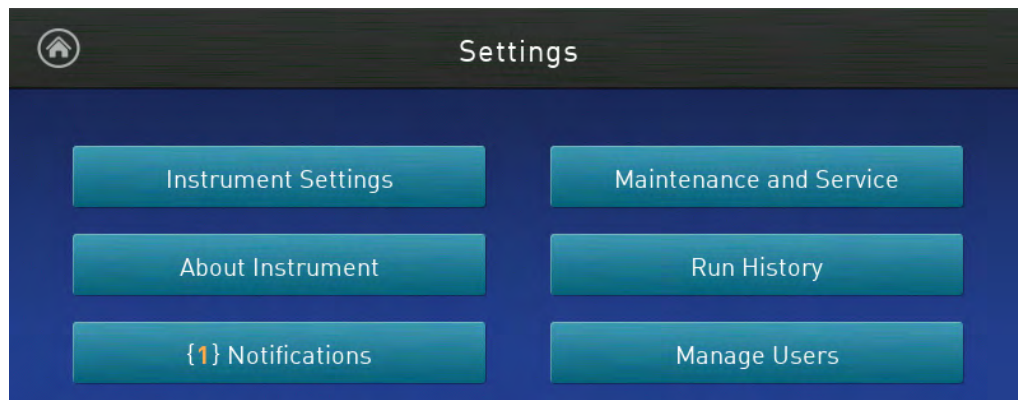

Options	Description
<b>Instrument Settings</b>	
<b>Instrument Name</b>	Enter a unique instrument name, and <i>(optional)</i> set an instrument avatar.
<b>Sleep Mode</b>	Enable the instrument to enter a sleep mode after a set length of inactivity.
<b>Heated Cover Temperature</b>	Set the idling temperature for the heated cover (before it enters sleep mode).
<b>Date/Time</b>	Set time zone and date and time formats.
<b>Restore Factory Defaults</b>	<p>Restore the instrument to the factory settings.</p> <p><b>IMPORTANT!</b> Back up the instrument before restoring factory defaults (see “Backup or restore the instrument” on page 48 ).</p> <p>When you restore an instrument to its factory defaults:</p> <ul style="list-style-type: none"> <li>• The following items are deleted:           <ul style="list-style-type: none"> <li>• All instrument profiles</li> <li>• All files stored on the instrument, including all EDS files</li> <li>• All custom dye calibrations, including calibrations for ABY™ and JUN™ dyes</li> <li>• RNase P verification</li> </ul> </li> <li>• The following items are <i>not</i> deleted:           <ul style="list-style-type: none"> <li>• The most recent valid ROI/uniformity and background calibrations</li> <li>• The most recent system dye calibrations</li> </ul> </li> </ul>
<b>About Instrument</b>	
<b>About Instrument</b> <sup>[1]</sup>	Displays the <b>Model Name</b> , <b>IP Address</b> , <b>Serial Number</b> , and <b>Firmware Version</b> .
<b>License Agreement</b> <sup>[1]</sup>	Displays the End User Software License Agreement and the Limited Product Warranty. You can export the License Agreement to a USB drive.



Options	Description
<b>Notifications</b> <sup>[1]</sup>	
—	Enable home screen notifications of instrument errors. The number of new, unviewed notifications displays over <b>Settings</b> in the home screen.
<b>Maintenance and Service</b>	
<b>Monitoring</b>	Enable the <b>Remote Monitoring Service</b> to automatically notify Thermo Fisher Scientific support teams in real time of potential instrument issues.  The service monitors and sends general <i>instrument</i> data, but the service does not monitor or send <i>customer</i> data.
<b>Instrument Statistics</b> <sup>[1]</sup>	Displays instrument usage information, including <b>Disk Space Remaining</b> , <b>LED Life</b> , and <b>RNase P Status</b> .
<b>Calibrations</b>	<ul style="list-style-type: none"> <li>• Perform calibrations. <ul style="list-style-type: none"> <li>– <b>ROI and Uniformity</b></li> <li>– <b>Dye</b></li> <li>– <b>Custom</b> (including calibrations for background and ABY™ and JUN™ dyes)</li> </ul> </li> <li>• View calibration history and set calibration reminders in <b>History and Reminders</b>.</li> </ul>
<b>RNase P Verification</b> <sup>[1]</sup>	Perform instrument performance verification using an RNase P plate.
<b>Self Verification Test</b> <sup>[1]</sup>	Check the instrument hardware functions.
<b>Log</b> <sup>[1]</sup>	View and export the <b>Instrument Run Log</b> .
<b>Backup / Restore</b>	<ul style="list-style-type: none"> <li>• Backup the instrument <sup>[1]</sup></li> <li>• Restore an instrument backup</li> </ul>
<b>Ship Prep Mode</b> <sup>[1]</sup>	Place the instrument in a safe state for moving or long-term storage.
<b>Run History</b> <sup>[1]</sup>	
—	Displays the instrument runs and whether the EDS file for the run was transferred. Touch a run to view its details or to transfer or delete ( <b>Administrator</b> only) its EDS file.
<b>Manage Users</b>	
<b>Sign In Required</b>	Enable only signed-in users to access the instrument for any task, including accessing <b>Settings</b> . Enabling this feature disables the guest profile access to the instrument.  <b>Note:</b> Instrument runs must be started from the desktop software, and actions during an instrument run are automatically logged to the guest instrument profile (even if a user was signed into the instrument).
<b>Sign Out Timer</b>	Set the time length of inactivity before a user is automatically signed out.
<b>Manage Profiles</b>	Access the profile information for the instrument.

<sup>[1]</sup> Also available to standard and guest instrument profiles.

## Overview of instrument settings *(Standard or Guest)*

Touch  **Settings** in the home screen to configure the instrument settings as needed. Access to most settings are restricted to administrator instrument profiles.

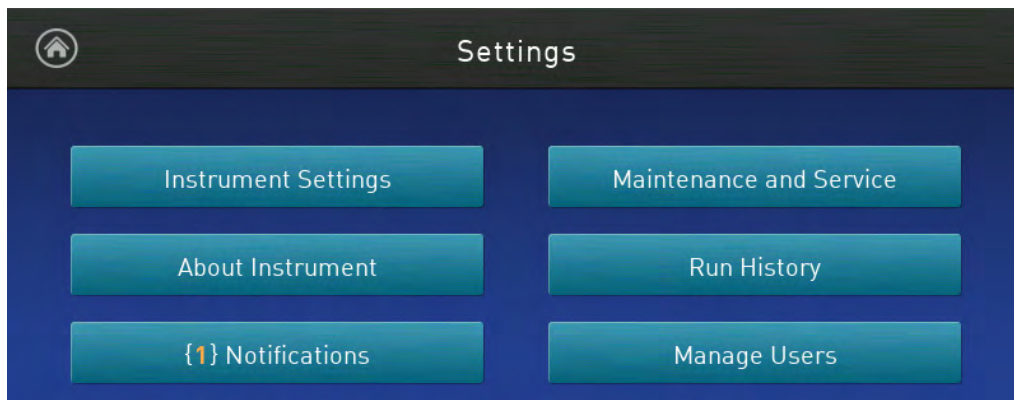

Options	Description
<b>About Instrument</b>	
<b>About Instrument</b>	Displays the <b>Model Name</b> , <b>IP Address</b> , <b>Serial Number</b> , and <b>Firmware Version</b> .
<b>License Agreement</b>	Displays the End User Software License Agreement and the Limited Product Warranty. You can export the License Agreement to a USB drive.
<b>Notifications</b>	
—	Enable home screen notifications of instrument errors. The number of new, unviewed notifications displays over <b>Settings</b> in the home screen.
<b>Maintenance and Service</b>	
<b>Instrument Statistics</b>	Displays instrument usage information, including <b>Disk Space Remaining</b> , <b>LED Life</b> , and <b>RNase P Status</b> .
<b>RNase P Verification</b>	Perform instrument performance verification using an RNase P plate.
<b>Self Verification Test</b>	Check the instrument hardware functions.
<b>Log</b>	View and export the <b>Instrument Run Log</b> .
<b>Backup / Restore</b>	Backup the instrument
<b>Ship Prep Mode</b>	Place the instrument in a safe state for moving or long-term storage.
<b>Run History</b>	
—	Displays the instrument runs and whether the EDS file for the run was transferred. Touch a run to view its details and to transfer its EDS file.

## Manage instrument profiles

**Note:** An instrument profile is a user account specifically for the instrument. It is not related to any other user account for the system or software.

To	See
Create a profile	<ul style="list-style-type: none"> <li>“Create an administrator instrument profile during initial start-up” on page 27</li> <li>“Create a new instrument profile” on page 28</li> </ul>
Configure a profile	<ul style="list-style-type: none"> <li>“Edit an instrument profile” on page 28</li> </ul>
View or manage all profiles	<ul style="list-style-type: none"> <li>“Manage all instrument profiles” on page 28</li> </ul>

### Instrument profiles and signed-in users

An instrument profile is a user account specifically for the instrument. It is not related to any other user account for the system or software.

Instrument profile type	Allowed actions
<b>Administrator</b>	All maintenance and administrative tasks, including instrument configuration
<b>Standard</b>	View instrument status, transfer files, and many maintenance tasks (such as Rnase P Verification and Self Verification Test)
<b>Guest</b>	View instrument status, transfer files, and many maintenance tasks (such as Rnase P Verification and Self Verification Test)  <b>Note:</b> All instrument runs and actions during a run are logged to the guest profile (even if a user was signed-in to the instrument when the run was started).

Instrument runs must be started from the desktop software. The instrument will automatically sign-off a signed-in user when an instrument run begins.

**Note:** To disable guest profile access to the instrument settings: ⚙️ **Settings** ▶ **Manage Users** ▶ **Sign In Required** set to on.

### Create an administrator instrument profile during initial start-up

During the initial instrument start-up or after restoring factory defaults, the instrument automatically prompts for the creation of an administrator profile.

- The first instrument profile created during installation is given administrator privileges.
- Administrators can grant administrative privileges to other users (see “Manage all instrument profiles” on page 28).

1. Touch **Name**, enter a username, then touch **Done**.
2. Touch **PIN**, enter a four-digit numerical password, then touch **Enter**.  
**Note:** Touch the **Show PIN** checkbox to switch PIN display on or off.
3. Touch **Confirm PIN**, then repeat step 2.
4. Touch **Create profile**.



**Create a new instrument profile**

In the home screen:

1. Touch  **Sign In**, then touch **Get Started**.
2. Touch **Name**, enter a username, then touch **Done**.
3. Touch **PIN Code**, enter a four-digit numerical password, then touch **Enter**.  
**Note:** Touch the **Show PIN** checkbox to switch PIN display on or off.
4. Touch **Confirm PIN**, then repeat step 2.
5. Touch **Create profile**.



**Edit an instrument profile**

In the home screen:

1. Touch  **My Profile**.  
**Note:** Administrators can also navigate to this screen by touching  **Settings** ▶ **Manage Users** ▶ **Manage Profiles**.
2. Touch **Edit**.
3. Select the fields to edit, then make changes.
4. Touch **Done**.

**Manage all instrument profiles**

In the home screen:

1. Access the **All Profiles** tab.
  - Touch  **My Profile** ▶ **All Profiles**.
  - Touch  **Settings** ▶ **Manage Users** ▶ **Manage Profiles** ▶ **All Profiles**.

A list of users, the date the profile was created, and the user type displays.

2. Select the instrument profile to edit.
3. Edit the profile.
  - To delete the profile, touch **Delete profile** ▶ **Delete**.
  - To reset the PIN, touch **Reset PIN** ▶ **Reset**.
    - The user will be directed to enter a new PIN at the next sign in.
  - To enable or disable administrative privileges, slide the control to **Administrator** or **Standard**, respectively.
4. Touch **Done**.

## Require instrument profile sign-in

In the home screen:

1. Touch  **Settings** ▶ **Manage Users** ▶ **Sign In Required**.
2. Slide the control **On**.  
Only signed-in users can access the instrument settings.
3. Touch **Done**.

**Note:** Instrument runs must be started from the desktop software, and actions during an instrument run are automatically logged to the guest instrument profile (even if a user was signed into the instrument).

## Manage the sign out timer

In the home screen:

1. Touch  **Settings** ▶ **Manage Users** ▶ **Sign Out Timer**.
2. Touch the **Edit Time** field, then enter the desired duration of inactivity before automatic user sign out.
3. Touch **Enter**, then touch **Done**.

## Manage the instrument name

In the home screen:

1. Touch  **Settings** ▶ **Instrument Settings** ▶ **Instrument Name**.
2. Touch the **Instrument Name** field, enter an instrument name, then touch **Done**.
3. *(Optional)* Touch **Add Avatar** to associate an avatar with the instrument.  
Insert a USB drive with image files to use this option.
4. Touch **OK**.

## Enable sleep mode

In the home screen:

1. Touch  **Settings** ▶ **Instrument Settings** ▶ **Sleep Mode**.
2. Slide the control **On** to enable sleep mode.
3. Touch **Edit Time**, then enter the time length of inactivity before the instrument enters sleep mode.
4. Touch **Enter**, then touch **OK**.

## Set the idling temperature for the heated cover

In the home screen:

1. Touch  **Settings** ▶ **Instrument Settings** ▶ **Heated Cover Idle Temperature**.
2. Slide the control **On** to set the idling temperature for the heated cover.
3. Touch the **Edit Temperature** field, then enter the desired idling temperature.
4. Touch **Enter**, then touch **OK**.

## Set the date and time

In the home screen:

1. Touch  **Settings** ▶ **Instrument Settings** ▶ **Date/Time**.
2. Select a time zone from the dropdown list.
3. Select a date format.
  - a. Touch **Date Format**, then select the preferred date format.
  - b. Touch **Next**, touch the date field, then enter the date.
  - c. Touch **Enter**, then touch **Done**.
4. Select a time format.
  - a. Touch **Time Format**.
  - b. Slide the control to select a 12-hour or 24-hour clock.
  - c. Touch **Next**, touch the time field, then enter the time.
  - d. Touch **Enter**, then touch **Done**.
5. Touch **Done**.

## Restore factory defaults

---

**IMPORTANT!** Back up the instrument before restoring factory defaults (see “Backup or restore the instrument” on page 48).

When you restore an instrument to its factory defaults:

- The following items are deleted:
    - All instrument profiles
    - All files stored on the instrument, including all EDS files
    - All custom dye calibrations, including calibrations for ABY™ and JUN™ dyes
    - RNase P verification
  - The following items are *not* deleted:
    - The most recent valid ROI/uniformity and background calibrations
    - The most recent system dye calibrations
- 

In the home screen:

1. Touch  **Settings** ▶ **Instrument Settings** ▶ **Restore Factory Defaults**.
2. Touch **Restore Factory Defaults**.
3. Power **Off**, then power **On** the instrument to apply the change.

After restoring factory defaults, perform the “Initial start up” tasks.

## Enable Remote Monitoring Service

**Note:** Enabling the **Remote Monitoring Service** allows the instrument to automatically notify Thermo Fisher Scientific support teams in real time of potential instrument issues. The service monitors and sends general *instrument* data, but the service does not monitor or send *customer* data.

In the home screen:

1. Touch  **Settings** ▶ **Maintenance and Service** ▶ **Monitoring**.
2. Slide the control **On** to enable the **Remote Monitoring Service**.
3. Touch **OK**.

## Update instrument software

---

**IMPORTANT!** Update the instrument software only under the specific guidance of your HID Support Representative.

---

In the home screen:

1. Touch  **Settings** ▶ **Maintenance and Service** ▶ **Software Update**.
2. Touch the location of the update files.
3. When prompted, confirm your request to update the software.





# Calibrate and verify instrument performance

- Calibration and verification schedule ..... 34
- Calibration descriptions ..... 35
- View calibration status and set reminders in the instrument ..... 36
- Perform ROI/uniformity, background, and dye calibrations ..... 36
- Calibrate dyes for HID-validated workflows ..... 41
- Perform instrument verification using RNase P plates ..... 44

## Calibration and verification schedule

The instrument is factory-calibrated and does not require calibration at installation. To ensure optimal performance, perform calibrations at the recommended frequency.

**Note:** During instrument installation, the Thermo Fisher Scientific service representative will perform the initial instrument verification using an RNase P plate and calibrate the instrument for the versions of ABY™ and JUN™ dyes used by HID-validated workflows.

---

**IMPORTANT!** Perform calibrations and instrument runs under the environmental conditions that are specified in “Environmental requirements” on page 65. Exposure to extreme temperatures can adversely affect the instrument performance and shorten the life span of the instrument components.

---

Set the calibration frequency for the instrument: Touch  **Settings** ▶ **Maintenance and Service** ▶ **Calibrations** ▶ **History and Reminders** ▶ **Edit** ▶ **Exp interval** field.

Calibration	Recommended frequency
ROI/Uniformity	<ul style="list-style-type: none"> <li>• Every two years (recommended)</li> <li>• Always perform new background and dye calibrations after an ROI/uniformity calibration.</li> </ul> <p><b>Note:</b> Performing an ROI/uniformity calibration invalidates all other calibrations.</p>
Background	<ul style="list-style-type: none"> <li>• Every two years (recommended)</li> <li>• Background calibration can also be performed, as needed:               <ul style="list-style-type: none"> <li>– To check for contamination (depends on usage and laboratory conditions).</li> <li>– To obtain the most accurate data for the removal of background fluorescence.</li> </ul> </li> </ul> <p><b>Note:</b> Performing a background calibration does <i>not</i> invalidate any other calibration.</p>
Dye ( <i>system and custom dyes, including ABY™ and JUN™ dyes</i> )	<ul style="list-style-type: none"> <li>• Every two years (recommended)</li> <li>• During a dye calibration, only the dyes on the given spectral calibration plate are calibrated.</li> </ul> <p><b>Note:</b> Performing a dye calibration for a given dye plate does <i>not</i> invalidate any other calibration.</p>
RNase P instrument verification	<ul style="list-style-type: none"> <li>• After performing instrument calibrations</li> <li>• As needed to confirm instrument performance</li> </ul>

## Calibration descriptions

Calibration description and purpose	Pass Criteria
<b>ROI/Uniformity</b>	
<ul style="list-style-type: none"> <li>The software captures images for each optical filter.</li> <li>The software uses calibration data to map the increase in fluorescence to the plate wells during subsequent runs and to evaluate well-to-well consistency of the signals.</li> </ul>	<p>The image for each filter distinguishes all wells of the plate.                      Each well in the image is distinct.</p>
<b>Background</b>	
<ul style="list-style-type: none"> <li>The software captures background images for each optical filter in the absence of sample and reagent, and it checks that the fluorescence from each well is below a fluorescence threshold.</li> <li>The software uses calibration data to remove background fluorescence during a run.</li> </ul> <p><b>Note:</b> You can also run this calibration to determine if contamination is related to the sample block or the plate.</p>	<p>The plate images for all filters are free of abnormal fluorescence.</p>
<b>Dye</b>	
<ul style="list-style-type: none"> <li>The software extracts a spectral profile for each dye standard, then produces a set of spectral profiles plotted as fluorescence vs filter.</li> <li>The software uses calibration data to characterize and distinguish the individual contribution of each dye in the total fluorescence signals collected by the instrument.</li> </ul>	<p>Dye spectra peak within the same filter as their group.</p>

## View calibration status and set reminders in the instrument

In the home screen:

1. Touch  **Settings** ▶ **Maintenance and Service** ▶ **Calibrations** ▶ **History and Reminders**.
2. In the **Calibration Reminders** screen, view the status of each calibration type.
3. *(Optional)* Touch a calibration row to view the history of that specific calibration type, then touch **Done**.
4. Touch **Edit** to set the calibration reminder settings. For each calibration type:
  - a. Slide the control **On** to enable the calibration reminder.
  - b. Edit the **Exp interval** and **Remind me** fields.
  - c. Touch **Save**.
5. *(Optional)* To transfer the calibration report, touch **Export** then follow the directions on the screen.
6. Touch **Done**.

## Perform ROI/uniformity, background, and dye calibrations

**Workflow:**  
**Calibration**

### **Perform an ROI/uniformity calibration**

*You are automatically prompted to perform background calibration.*



### **Perform a background calibration**

*Perform any time that ROI/uniformity calibrations are current.*



### **Perform system dye calibrations**

*Perform any time that ROI/uniformity and background calibrations are current.*



### **Perform dye calibrations for ABY™ and JUN™ dyes (page 41)**

*Perform any time that ROI/uniformity and background calibrations are current.*

## Prepare a calibration plate

### Materials required for calibration plate preparation

- Plate(s) for the calibration you are performing:
  - ROI/Uniformity plate (one ROI plate needed)
  - Background calibration plate
  - Dye calibration plates

**Note:** We recommend calibrating with all Spectral Dye Calibrations Plates even if you are not using all the dyes in the plates.

**Note:** Do not discard the packaging for the calibration plates. Each calibration plate can be used up to 3 times if the plate is:

- Stored in its packing sleeve at  $-15$  to  $-25^{\circ}\text{C}$
- Used within 6 months after opening
- Used before the plate expiry date
- Centrifuge with plate adapter; buckets cleaned before use
- Powder-free gloves
- Safety glasses

### Thaw, vortex, and centrifuge a calibration plate

1. Remove the calibration plate from the freezer, then thaw the plate in its packaging. Keep plates protected from light until you perform the calibration.
  - Thaw each plate for 30 minutes.
  - Use each plate within 2 hours of thawing.

---

**IMPORTANT!** Do not remove the plate from its packaging until you are ready to use it. The fluorescent dyes in the wells of calibration plates are photosensitive. Prolonged exposure to light can diminish the fluorescence of the dyes.

---

2. While wearing powder-free gloves, remove the calibration plate from its packaging and retain the packaging. Do not remove the optical film.
3. Vortex the plate for 5 seconds, then centrifuge at  $750$  to  $1,000 \times g$  for 2 minutes.
4. Confirm that the liquid in each well is at the bottom of the well and free of bubbles. If it is not, centrifuge the plate again.

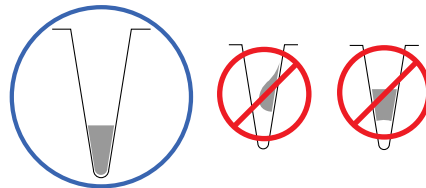



---

**IMPORTANT!** Keep the bottom of the plate clean. Fluids and other contaminants on the bottom of the plate can contaminate the sample block and cause an abnormally high background signal.

---

## Perform calibrations

1. In the instrument home screen:

Calibration	Touch
ROI/Uniformity <sup>[1]</sup>	 <b>Settings</b> ▶ <b>Maintenance and Service</b> ▶ <b>Calibrations</b> ▶ <b>ROI and Uniformity</b>
Background <sup>[2]</sup>	 <b>Settings</b> ▶ <b>Maintenance and Service</b> ▶ <b>Calibrations</b> ▶ <b>Custom</b> ▶ <b>Background</b>
System Dye	 <b>Settings</b> ▶ <b>Maintenance and Service</b> ▶ <b>Calibrations</b> ▶ <b>Dye</b>

<sup>[1]</sup> Automatically followed by background calibration.

<sup>[2]</sup> Initiate via this route if performing background calibration only.

2. Follow the instructions on the screen to start the calibration.

**Note:** For dye calibration only: Select the **Dye Plate** to run, then touch **Next**.

3. Load the plate into the instrument.

---

**IMPORTANT!** The instrument should be used by trained operators who have been warned of the moving parts hazard.

---

4. Touch **Start**.

5. When the run is complete and the screen displays **Calibration Complete**, touch **View Results** to check the calibration status.

Calibration status	Action
Passed	Touch <b>Next</b> to proceed to the next required calibration.
Failed	See "Troubleshoot calibration failure" on page 56.

**Note:** You can view the calibration images only after the ROI/uniformity and background calibrations pass.

6. Unload the plate from the instrument.



**CAUTION! PHYSICAL INJURY HAZARD.** During instrument operation, the plate temperature can reach 100°C. Allow it to cool to room temperature before handling.

---

**Note:** If the instrument does not eject the plate, contact Support.

7. Return the plate to its original packaging.

**Note:** Each calibration plate can be used up to 3 times if the plate is:

- Stored in its packing sleeve at -15 to -25°C
- Used within 6 months after opening
- Used before the plate expiry date

## View calibration images

You can view the calibration images after the background calibration is complete.

1. In the **Calibration Status** screen, touch **Details**.
2. In the **Details** screen, touch a calibration type to view its images and plots.

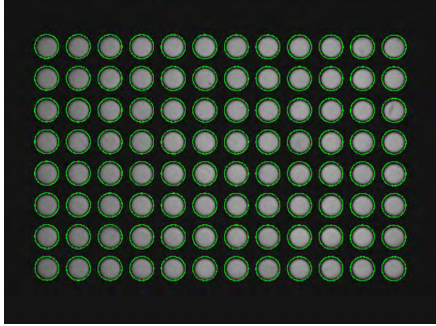
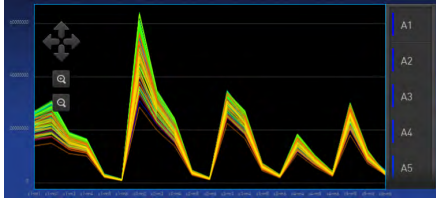
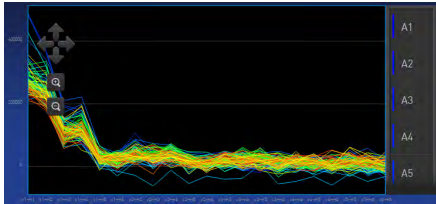
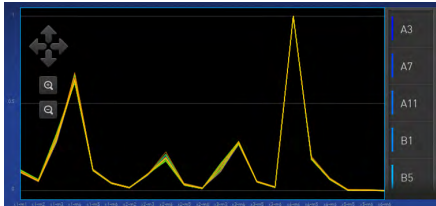
Calibration	Example results indicating successful calibration
ROI <b>Note:</b> Select the desired filter combination from the Filter Set dropdown list.	Green circles around all wells and bright well centers. 
Uniformity	Signals from each well following a uniform trend. 
Background	Few, if any, signals with abnormally high fluorescence. 
Dye	Signals from each well following a uniform trend, and each dye peaks at the correct filter. 

3. In the **Calibration Status** screen, touch **Accept Results** or **Reject Results**.  
 Accepting the results saves the calibration data to the instrument and overwrites existing data.

## Identify contamination

Signals that exceed the limit of normal fluorescence may indicate fluorescent contaminants on the calibration plate or the sample block. Common contaminants include ink residue from permanent pens, powder from disposable gloves, and dust.

To identify and resolve a possible contamination problem:

1. View the calibration data and note the wells that failed the calibration.
2. Remove the plate from the instrument, rotate the plate 180°, then perform the calibration again.
3. Determine the location of the failed wells again as in step 1.

Position of failed wells	Action
Identical	The sample block is contaminated. Decontaminate the sample block (see page 49).
Reversed	The plate is contaminated. Discard the plate, then perform the calibration using a new calibration plate.

4. If the calibration fails after you decontaminate the sample block and replace the plate, contact Support.

## Create a background plate (optional)

Whenever possible, use a background plate listed in Appendix B, “Parts and materials“. These plates contain a buffer that accurately simulates the reagents used for PCR, and, therefore, produces high-quality calibration data.

If a background plate is not available, you can create one as described below.

### Required materials:

- MicroAmp™ optical 96-well reaction plate
- Optical adhesive cover or optical flat caps
- Pipettor, 200- $\mu$ L (with pipette tips)
- Powder-free gloves
- Safety glasses
- Deionized water

---

**IMPORTANT!** Wear powder-free gloves while creating the background plate.

---

1. Remove a reaction plate from its box and place it on a clean, dry surface.
2. Aliquot 50  $\mu$ L of deionized water to each well of the reaction plate.
3. Seal the plate using an optical adhesive cover or optical flat caps.
4. Use the plate for background calibration.



## Calibrate dyes for HID-validated workflows

HID-validated workflows use versions of ABY™ and JUN™ dyes that are considered custom dyes for the instrument. These dyes require custom dye calibration.

To calibrate any other custom dye, contact your HID Support Representative.

---

**IMPORTANT!** To perform a custom dye calibration for HID-validated workflows, use the following prepared spectral calibration plates:

- ABY™ Spectral Calibration Plate, 96-Well 0.2-mL (Cat. No. 4461591)
  - JUN™ Spectral Calibration Plate, 96-Well 0.2-mL (Cat. No. 4461593)
- 

### Workflow: Calibrate dyes for HID-validated workflows

Prepare a calibration plate (page 41)



Add the custom dye to the instrument (page 42)



Perform a custom dye calibration (page 42)

### Prepare a calibration plate for HID-validated workflows

#### Materials required for calibration plate preparation

- Plate(s) for the calibration you are performing:
  - ABY™ Spectral Calibration Plate, 96-Well 0.2-mL (Cat. No. 4461591)
  - JUN™ Spectral Calibration Plate, 96-Well 0.2-mL (Cat. No. 4461593)

**Note:** Do not discard the packaging for the calibration plates. Each calibration plate can be used up to 3 times if the plate is:

- Stored in its packing sleeve at –15 to –25°C
- Used within 6 months after opening
- Used before the plate expiry date
- Centrifuge with plate adapter; buckets cleaned before use
- Powder-free gloves
- Safety glasses

#### Thaw, vortex, and centrifuge a calibration plate

1. Remove the calibration plate from the freezer, then thaw the plate in its packaging. Keep plates protected from light until you perform the calibration.
  - Thaw each plate for 30 minutes.
  - Use each plate within 2 hours of thawing.

---

**IMPORTANT!** Do not remove the plate from its packaging until you are ready to use it. The fluorescent dyes in the wells of calibration plates are photosensitive. Prolonged exposure to light can diminish the fluorescence of the dyes.

---

2. While wearing powder-free gloves, remove the calibration plate from its packaging and retain the packaging. Do not remove the optical film.

- Vortex the plate for 5 seconds, then centrifuge at 750 to 1,000 × g for 2 minutes.
- Confirm that the liquid in each well is at the bottom of the well and free of bubbles. If it is not, centrifuge the plate again.

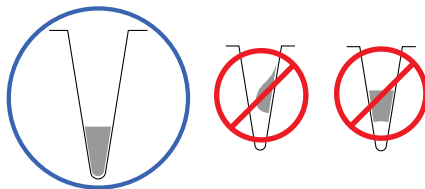

---

**IMPORTANT!** Keep the bottom of the plate clean. Fluids and other contaminants on the bottom of the plate can contaminate the sample block and cause an abnormally high background signal.

---

### Add custom dyes to the instrument for HID-validated workflows

- In the instrument home screen, touch **Settings** ▶ **Maintenance and Service** ▶ **Calibrations** ▶ **Custom** ▶ **Custom Dye**.
- Touch **Add Custom Dye**.
- Enter the dye information:

Field/option	Action
Custom Dye Name	Enter the names for the custom dyes: <ul style="list-style-type: none"> <li>• ABY-HID</li> <li>• JUN-HID</li> </ul> <p><b>IMPORTANT!</b> Dye names are spacing sensitive.</p>
Type	Select: <ul style="list-style-type: none"> <li>• <b>ABY-HID</b>—Reporter</li> <li>• <b>JUN-HID</b>—Reporter</li> </ul>

- Touch **Save**.

### Perform a custom dye calibration for HID-validated workflows

- Load the plate into the instrument.

---

**IMPORTANT!** The instrument should be used by trained operators who have been warned of the moving parts hazard.

---

- In the instrument home screen, touch **Settings** ▶ **Maintenance and Service** ▶ **Calibrations** ▶ **Custom** ▶ **Custom Dye**.
- Touch the custom dye to calibrate.
- Review the custom dye information, (*optional*) make changes, then touch **Update**.
- Enter the calibration temperature.
- (*Optional*) Touch **Reagents**, then enter reagent information.

7. Touch **Start**.
8. When the run is complete and the screen displays **Calibration Complete**, touch **View Results ▶ Details**.
9. Review the plot. Passing calibration results show uniform signals with peaks aligned with the dye wavelength.

Dye	Peak filter	Filter wavelength (nm)	
		Excitation	Emission
ABY-HID	x3-m3	550 ± 10	587 ± 10
JUN-HID	x4-m4	580 ± 10	623 ± 14

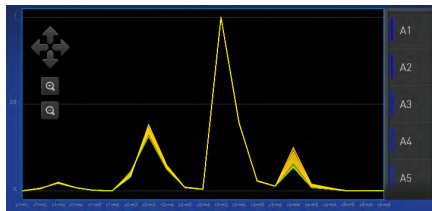

ABY-HID dye calibration plot

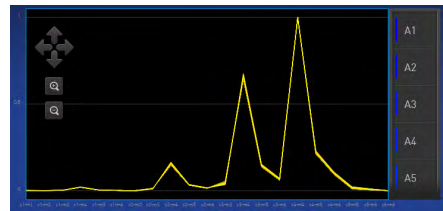

JUN-HID dye calibration plot

10. Select an action depending on whether the custom dye calibration passed or failed.

Calibration status	Action
Passed	Touch <b>Accept Results</b> or <b>Reject Results</b> . <b>Note:</b> Accepting the results saves the calibration data to the instrument and overwrites existing data.
Failed	See “Troubleshoot calibration failure” on page 56.

11. Unload the plate from the instrument.



**CAUTION! PHYSICAL INJURY HAZARD.** During instrument operation, the plate temperature can reach 100°C. Allow it to cool to room temperature before handling.

**Note:** If the instrument does not eject the plate, contact Support.

## Perform instrument verification using RNase P plates

During instrument installation, your HID Support Representative will perform instrument verification. However, perform instrument verification:

- After performing instrument calibrations.
- As needed to confirm instrument performance.

The instrument requires valid ROI/uniformity, background, and dye calibrations to perform instrument verification.

### Instrument verification description

Purpose	Description	Pass criteria
Confirms the performance of the instrument.	Quantifies the number of copies of the human RNase P gene in samples with known concentrations of the corresponding DNA template.	<p>The instrument passes performance specifications if the following inequality is true and the instrument successfully distinguishes between unknown populations A and B with a statistical confidence level of 99.7%.</p> $[[C_{tA}] - 3\{\sigma_{CtA}\}] > [[C_{tB}] + 3\{\sigma_{CtB}\}]$ <p>where:</p> <ul style="list-style-type: none"> <li>• <math>C_{tA}</math> = Average <math>C_t</math> of unknown population A</li> <li>• <math>\sigma_{CtA}</math> = Standard deviation of unknown population A</li> <li>• <math>C_{tB}</math> = Average <math>C_t</math> of unknown population B</li> <li>• <math>\sigma_{CtB}</math> = Standard deviation of unknown population B</li> </ul>

## RNase P instrument verification plate

The RNase P plate contains the reagents necessary for the detection and quantitation of genomic copies of the human RNase P gene (a single-copy gene encoding the RNase moiety of the RNase P enzyme). Each well contains: PCR master mix, RNase P primers, FAM™ dye-labeled probe, and a known concentration of human genomic DNA template.

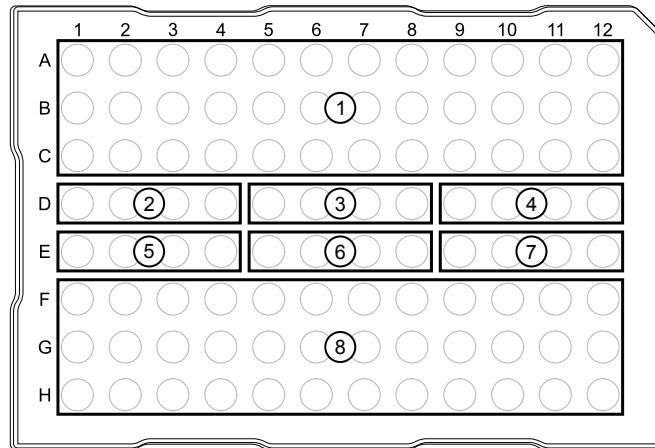

**Figure 3** 96-well RNase P plate

- |                             |                      |
|-----------------------------|----------------------|
| ① Unknown A (5,000)         | ⑤ STD 5,000 copies   |
| ② NTC (no template control) | ⑥ STD 10,000 copies  |
| ③ STD 1,250 copies          | ⑦ STD 20,000 copies  |
| ④ STD 2,500 copies          | ⑧ Unknown B (10,000) |

## Performance specifications pass criteria

After the run, the software calculates average copy number values and standard deviation values. The instrument passes performance specifications if the following inequality is true and the instrument successfully distinguishes between unknown populations A and B with a statistical confidence level of 99.7%.

$$[(C_{tA}) - 3(\sigma_{CtA})] > [(C_{tB}) + 3(\sigma_{CtB})]$$

where:

- $C_{tA}$  = Average  $C_t$  of unknown population A
- $\sigma_{CtA}$  = Standard deviation of unknown population A
- $C_{tB}$  = Average  $C_t$  of unknown population B
- $\sigma_{CtB}$  = Standard deviation of unknown population B

The software automatically adjusts the threshold and omits a defined number of wells from the unknown populations to meet the performance specifications. To view any omitted wells, open the EDS file for the verification in the desktop software.

## Prepare an RNase P plate

### Materials required for RNase P plate preparation

- RNase P instrument verification plate
- Centrifuge with plate adapter; buckets cleaned before use
- Powder-free gloves
- Safety glasses

### Thaw, vortex, and centrifuge an RNase P plate

1. Remove the RNase P plate from the freezer, then thaw the plate in its packaging.
  - Thaw the plate for approximately 5 minutes.
  - Use the plate within 30 minutes of thawing.
2. While wearing powder-free gloves, remove the plate from its packaging.
3. Vortex the plate for 5 seconds, then centrifuge at 750 to 1,000 × g for 2 minutes.
4. Confirm that the liquid in each well is at the bottom of the well and free of bubbles. If it is not, centrifuge the plate again.

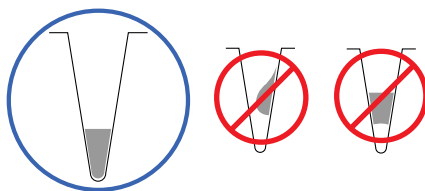

---

**IMPORTANT!** Keep the bottom of the plate clean. Fluids and other contaminants on the bottom of the plate can contaminate the sample block and cause an abnormally high background signal.

---

## Perform RNase P verification

1. In the home screen, touch  **Settings** ▶ **Maintenance and Service** ▶ **RNase P Verification**.
2. Load the plate into the instrument.

---

**IMPORTANT!** The instrument should be used by trained operators who have been warned of the moving parts hazard.

---

3. Touch **Start**.
4. When the run is complete and the screen displays **Verification Complete**, touch **View Results** to confirm the status of the run.

Calibration status	Action
Passed	Instrument is ready for use.
Failed	See “Troubleshoot verification failure” on page 57.

5. In the **RNase P Verification Status** screen, touch:
  - **Accept Results** to save the results to the instrument
  - **Reject Results** to delete the RNase P verification results
  - **Export Results** to export the calibration results to a USB
6. Unload the plate from the instrument.



**CAUTION! PHYSICAL INJURY HAZARD.** During instrument operation, the plate temperature can reach 100°C. Allow it to cool to room temperature before handling.

---

**Note:** If the instrument does not eject the plate, contact Support.

# 6

## Maintain the instrument

- Backup or restore the instrument ..... 48
- Decontaminate the sample block ..... 49
- Replace the instrument fuses ..... 52
- Store, move, or ship the instrument ..... 53

---



**IMPORTANT!** This chapter contains user maintenance procedures for the instrument. Procedures other than those described in this document must be performed by a qualified Service Engineer.

---

### Backup or restore the instrument

In the home screen:

Touch  **Settings** ▶ **Maintenance and Service** ▶ **Backup/Restore**.

To	Action
Backup	<ol style="list-style-type: none"> <li>1. Insert a USB into the front-panel USB port.</li> <li>2. Touch <b>Backup Instrument</b>.</li> <li>3. Touch  <b>USB</b>.</li> <li>4. Enter a backup file name, then touch <b>Done</b>.</li> <li>5. Select which elements to backup, or leave them all selected.</li> <li>6. Touch <b>Backup</b>.</li> </ol>
Restore (Administrator only)	<ol style="list-style-type: none"> <li>1. Insert the USB that contains the backup file into the front-panel USB port.</li> <li>2. Touch <b>Restore a Backup</b>.</li> <li>3. Touch  <b>USB</b>.</li> <li>4. Select the backup file, then touch <b>Restore</b>.</li> </ol>



## Decontaminate the sample block

Perform this procedure to eliminate fluorescent contaminants from the instrument sample block. Contamination is generally evident in failed background calibrations where one or more wells consistently exhibit abnormally high signals.



**CAUTION! PHYSICAL INJURY HAZARD.** Do not remove the instrument cover. There are no components inside the instrument that you can safely service yourself. If you suspect a problem, contact Support.

---



**CAUTION! PHYSICAL INJURY HAZARD.** During instrument operation, the sample block temperature can reach 100°C. Allow it to cool to room temperature before handling.

---



**CAUTION!** Before using a cleaning or decontamination method other than those recommended by Thermo Fisher Scientific, confirm with Thermo Fisher Scientific that the proposed method will not damage the equipment.

---

### Materials required

- Safety glasses
- Powder-free gloves
- Tissue, lint-free
- Cotton or nylon swabs and lint-free cloths
- Pipette (100- $\mu$ L) with pipette tips
- Deionized water
- Ethanol, 95% solution
- Bleach, 10% solution

### Clean the sample block



**CAUTION! PHYSICAL INJURY HAZARD.** During instrument operation, the sample block temperature can reach 100°C. Allow it to cool to room temperature before handling.

---

**IMPORTANT!** Wear powder-free gloves when you perform this procedure.

---

**IMPORTANT!** Always use deionized water to rinse wells after cleaning with bleach or ethanol solution.

---

1. Identify the contaminated wells of the sample block (see page 40).
2. Prepare the instrument and access the sample block:
  - a. Power off and unplug the instrument, then allow it to cool for 15 minutes.
  - b. Pull the instrument drawer forward to expose the sample block.

3. Rinse the contaminated wells with deionized water (see page 51).

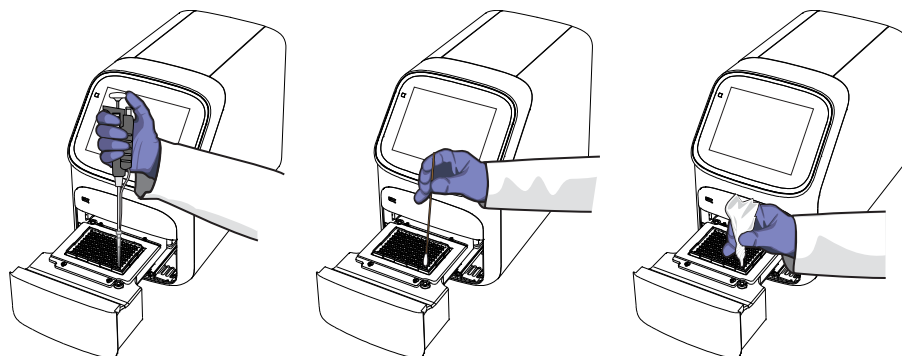

4. Close the drawer and test the sample block for contamination:
  - a. Push the instrument drawer back in to the instrument.
  - b. Plug in, then power on the instrument.
  - c. Perform a background calibration to confirm that you have eliminated the contamination.
5. If the contamination remains:
  - a. Repeat step 2 – step 3.
  - b. Clean the contaminated wells using a 95% ethanol solution (see page 51).
  - c. Repeat step 3 – step 4 to rinse the sample block with deionized water and to confirm that you have eliminated the contamination.

---

**IMPORTANT!** Always use deionized water to rinse wells after cleaning with bleach or ethanol solution.

---

6. If the contamination still remains:
  - a. Repeat step 2 – step 3.
  - b. Clean the contaminated wells using a 10% bleach solution (see page 51).
  - c. Repeat step 3 – step 4 to rinse the sample block with deionized water and to confirm that you have eliminated the contamination.

---

**IMPORTANT!** Always use deionized water to rinse wells after cleaning with bleach or ethanol solution.

---

7. If the contamination continues to remain, contact Support.

## Detailed procedures for cleaning the sample block

---

**IMPORTANT!** Use these cleaning procedures *only* in conjunction with the "Clean the sample block" procedures.

---

### Rinse the sample block with deionized water

1. Pipet a small volume of deionized water into each contaminated well.
2. In each well, pipet the water up and down several times to rinse the well.
3. Pipet the water to a waste beaker.
4. Use a cotton swab to scrub inside of each contaminated well.
5. Use a lint-free cloth to absorb the excess deionized water.

### Clean the sample block with 95% ethanol

1. Pipet a small volume of 95% ethanol solution into each contaminated well.
2. In each well, pipet the solution up and down several times to rinse the well.
3. Pipet the ethanol solution to a waste beaker.

**IMPORTANT!** Always use deionized water to rinse wells after cleaning with bleach or ethanol solution.

### Clean the sample block with 10% bleach

1. Pipet a small volume of 10% bleach solution into each contaminated well.
2. In each well, pipet the solution up and down several times to rinse the well.
3. Pipet the bleach solution to a waste beaker.

**IMPORTANT!** Always use deionized water to rinse wells after cleaning with bleach or ethanol solution.

## Replace the instrument fuses



**CAUTION! FIRE HAZARD.** For continued protection against the risk of fire, replace fuses only with listed and certified fuses of the same type and rating as those currently in the instrument.

### Materials required



- Fuses (2) – 10A, Time-Lag T, 250VAC, 5 × 20mm
- Safety glasses
- Powder-free gloves
- Screwdriver, flathead

### Replace the fuses

1. Power off and unplug the instrument, then allow it to cool for 15 minutes.
2. Using a flat-head screwdriver, unscrew and remove the fuse holder.



3. Remove each fuse from its fuse holder and inspect it for damage. Carbon typically coats the inside of failed fuses.

Good	Failed
	

4. Replace each failed fuse.

**Note:** The voltage and amperage ratings are on the fuse holder.

5. Install the fuse holder back into the instrument.

6. Plug in, then power on the instrument.



The installation is successful if the instrument powers on.

**Note:** Fuse failure can result from fluctuations in the supplied power to the system. To prevent further failures, consider installing an electrical protective device, such as a UPS or a surge protector. If issues with the fuse persist, contact Support.

## Store, move, or ship the instrument

### Prepare the instrument to store, move, or ship

In the home screen:

1. Touch  **Settings** ▶ **Maintenance and Service** ▶ **Ship Prep Mode** ▶ **Next**.
2. Touch  to eject the instrument drawer.
3. Load the packing plate or an empty plate, then touch  to close the drawer.
4. Touch **Lock Block**.
5. Power off the instrument using the power switch on the back of the instrument.

The instrument is now ready to store, move, or ship.

### Move the instrument



---

**CAUTION! PHYSICAL INJURY HAZARD.** Do not attempt to lift the instrument or any other heavy objects unless you have received related training. Incorrect lifting can cause painful and sometimes permanent back injury. Use proper lifting techniques when lifting or moving the instrument. At least two people are required to lift it.

---

---

**IMPORTANT!** Moving your instrument can create subtle changes in the alignment of the instrument optics. Recalibrate the instrument if necessary.

---

- Ensure that the surface on which you place the instrument can support at least 35 kg (77 lbs).
- Ensure that the path to transport the instrument is clear of obstructions.
- At least two people are needed to lift and carry the instrument.
- Keep your spine in a good neutral position.
- Bend at the knees and lift with your legs.
- Do not lift an object and twist your torso at the same time.
- Coordinate your intentions with your assistant before lifting and carrying.

---

**IMPORTANT!** After moving the instrument, perform an RNase P instrument verification run. If the run fails, perform ROI/ uniformity, background, and dye calibrations.

---

## Return the instrument for service

The service process requires 2 to 3 weeks.

Before returning the instrument for service:

1. Back up the instrument (see “Backup or restore the instrument” on page 48).
2. In the home screen, touch  **Settings** ▶ **Instrument Settings** ▶ **Reset Factory defaults**.
3. Set the instrument to **Ship Prep Mode** (see “Prepare the instrument to store, move, or ship” on page 53).

To return the instrument for service:

1. Contact your local customer care center or technical support group to obtain a copy of the Certificate of Instrument Decontamination, a service notification, a service call number, and packaging materials (if required).

2. Follow the instructions in the form to decontaminate the instrument.

---

**IMPORTANT!** The instrument must be decontaminated before packing it for shipping.

---

3. Complete and sign a copy of the Certificate of Instrument Decontamination.
4. Fax the Certificate of Instrument Decontamination to the customer care center.
5. Pack the instrument in the provided packaging and follow the instructions in the table below.

Prepare	Include	Exclude
<ol style="list-style-type: none"> <li>1. Transfer any data files from the instrument.</li> <li>2. Load an empty plate in the sample block.</li> <li>3. Use the touchscreen to place the instrument in ship mode.</li> </ol> <p><b>Note:</b> The empty plate and ship mode protects the internal components of the instrument during transport.</p>	<ul style="list-style-type: none"> <li>• Instrument</li> <li>• Completed and signed Certificate of Instrument Decontamination</li> </ul> <p><b>Note:</b> The instrument will not be accepted for service without a hard copy of the Certificate of Instrument Decontamination.</p>	<p>Any accessories, including:</p> <ul style="list-style-type: none"> <li>• Power cord</li> <li>• Ethernet cable</li> <li>• USB drive</li> <li>• Wireless adapter</li> </ul> <p><b>Note:</b> If included with the instrument, these items will be disposed of during service and not returned.</p>

6. Attach the postage provided with the Certificate of Instrument Decontamination to the box, then ship the instrument to the designated facility.



# Troubleshooting

## Instrument troubleshooting

Observation	Possible cause	Recommended action
Insufficient disk space message	Insufficient disk space to save a run.	<ol style="list-style-type: none"> <li>In the home screen, touch  <b>Settings</b> ▶ <b>Run History</b> ▶ <b>Manage</b>.</li> <li>Delete or transfer experiments from the instrument.</li> </ol>
The touchscreen is black	The instrument is in sleep mode.	Touch anywhere on the instrument touchscreen.
	The instrument is not powered on.	If you touch the instrument touchscreen and it remains black, check if the instrument is powered on. The power switch is located on the rear panel of the instrument.
		If the instrument does not power on, check that the instrument is properly plugged in.
Forgot PIN for instrument profile	Non-administrator forgot instrument profile PIN.	See “Manage all instrument profiles” on page 28.
	Administrator forgot instrument profile PIN.	Have another administrator reset the PIN for the forgotten-PIN profile (see “Manage all instrument profiles” on page 28).
		If there is not another administrator profile on the instrument, you must restore factory defaults (see “Restore factory defaults” on page 31).



## Troubleshoot calibration failure

Observation	Possible cause	Recommended action
Calibration failed	The plate was improperly prepared.	Ensure the following: <ul style="list-style-type: none"> <li>• The correct plate was used for the calibration performed.</li> <li>• The plate was properly thawed.</li> <li>• The plate was properly centrifuged.</li> <li>• The heat seal of the plate was properly sealed.</li> </ul>
	The plate is damaged or contaminated.	Check for damage, improper heat seal, or contamination.
		Order a replacement plate. If the replacement plate fails, contact Support.
High fluorescence signal	Signals that exceed the limit of normal fluorescence may indicate fluorescent contaminants on the plate or the sample block.	See "Identify contamination" on page 40.
Calibration failed but plate is undamaged	The incorrect plate was used for calibration performed.	Use the plate that matches the calibration performed.
	The plate was improperly prepared.	Repeat the calibration with the plate properly prepared.
		If the calibration fails again, order a replacement plate. If the replacement plate fails, contact Support.



## Troubleshoot verification failure

Observation	Possible cause	Recommended action
Verification failed	The plate was improperly prepared.	Ensure the following: <ul style="list-style-type: none"> <li>• The correct plate was used for the verification performed.</li> <li>• The plate was properly thawed.</li> <li>• The plate was properly centrifuged.</li> <li>• The heat seal of the plate was properly sealed.</li> </ul>
	The plate is damaged or contaminated.	Check for damage, improper heat seal, or contamination.
		Order a replacement plate. If the replacement plate fails, contact Support.
High fluorescence signal	The reaction volume is not correct.	Ensure that reaction volumes in the plate are correct and match the volume that is entered in the <b>Method</b> tab.
	Signals that exceed the limit of normal fluorescence may indicate fluorescent contaminants on the plate or the sample block.	Examine the bottom of the reaction plate. If there is contamination, prepare a new plate and run the experiment again.
		Identify the location of contamination on the plate or sample block. <ol style="list-style-type: none"> <li>1. Obtain or prepare a background plate (see page 40).</li> <li>2. Follow the procedures that are described in "Identify contamination" on page 40.</li> </ol>
Verification failed but plate is undamaged	The incorrect plate was used for verification.	Use the correct RNase P plate for verification.
	The plate was improperly prepared.	Repeat the verification with a new properly prepared plate. <b>Note:</b> The verification procedure is an instrument run, so each RNase P plate can only be used once.
		If the verification fails again, order a replacement plate. If the replacement plate fails, contact Support.



# Parts and materials

- Kits, consumables, accessories, and reagents ..... 58
- Consumables (96-well, 0.2-mL format) ..... 59
- Accessories ..... 60
- General-use materials and consumables ..... 60

## Kits, consumables, accessories, and reagents

Unless otherwise indicated, all materials are available through [thermofisher.com](http://thermofisher.com).

Store all calibration and RNase P plates at  $-20^{\circ}\text{C}$ . All other items can be stored at  $15\text{--}30^{\circ}\text{C}$ . Use all materials by the expiration date on the packaging.

## Consumables (96-well, 0.2-mL format)

Consumable	Amount	Cat. No.
MicroAmp™ Optical 8-Cap Strips	300 strips	4323032
MicroAmp™ Optical 8-Tube Strip, 0.2 mL	125 strips	4316567
MicroAmp™ Optical Tube without Cap, 0.2 mL	2,000 tubes	N8010933
MicroAmp™ Optical 96-Well Reaction Plate with Barcode	20 plates	4306737
	500 plates	4326659

Instrument verification or calibration plate	Cat. No.
TaqMan® RNase P Instrument Verification Plate, 96-Well 0.2-mL	4432382
Region of Interest (ROI) and Background Plates, 96-Well 0.2-mL (2 plates)	4432364
QuantStudio™ 3/5 10-Dye Spectral Calibration Kit, 96-Well 0.2-mL (contains all 3 spectral calibration plates listed below)	A26343
QuantStudio™ 3/5 Spectral Calibration Plate 1, 96-Well 0.2-mL (FAM™, VIC™, ROX™, and SYBR™ dyes)	A26331
QuantStudio™ 3/5 Spectral Calibration Plate 2, 96-Well 0.2-mL (ABY™, JUN™, and MUSTANG PURPLE™ dyes)	A26332
QuantStudio™ 3/5 Spectral Calibration Plate 3, 96-Well 0.2-mL (TAMRA™, NED™, and Cy®5 dyes)	A26333
Spectral calibration plates for dyes used with HID-validated workflows	
ABY™ Spectral Calibration Plate, 96-Well 0.2-mL	4461591
JUN™ Spectral Calibration Plate, 96-Well 0.2-mL	4461593

## Accessories

Item	Amount	Cat. No.
MicroAmp™ 96-Well Tray/Retainer Set	10 trays	4381850
MicroAmp™ Multi Removal Tool	1 tool	4313950
MicroAmp™ Cap Installing Tool (handle style)	1 tool	4330015
MicroAmp™ Optical Adhesive Film	25 films	4360954
	100 films	4311971
MicroAmp™ Adhesive Film Applicator	5 applicators	4333183

## General-use materials and consumables

The following general-use materials and consumables are required to calibrate, maintain, and operate the instrument. Unless otherwise indicated, all materials are available through [thermofisher.com](http://thermofisher.com).

Material/Consumable	Source
Bleach, 10% solution	MLS
Centrifuge with 96-well plate buckets	MLS
Cotton or nylon swabs and lint-free cloths	MLS
Ethanol, 95% solution	MLS
Optical clear adhesive film for PCR	MLS
Pipettors, 100- $\mu$ L and 200- $\mu$ L (with pipette tips)	MLS
Powder-free gloves	MLS
Safety glasses	MLS
Screwdriver, flathead	MLS
Tissue, lint-free	MLS
Deionized water	MLS



# Instrument specification and layout

■ Configured system dimensions .....	62
■ Instrument and computer connections .....	63
■ Instrument clearances .....	64
■ Electrical requirements .....	64
■ Environmental requirements .....	65

## Configured system dimensions

Allow space for the configured instrument. A typical setup with a co-located minitower computer is shown below.

**Note:** Dimensions are rounded to the nearest whole or half unit.

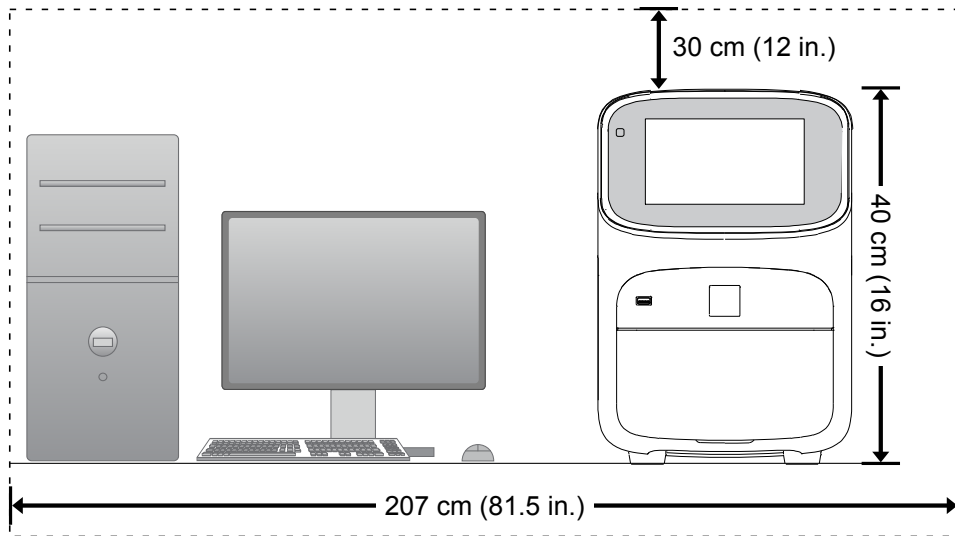
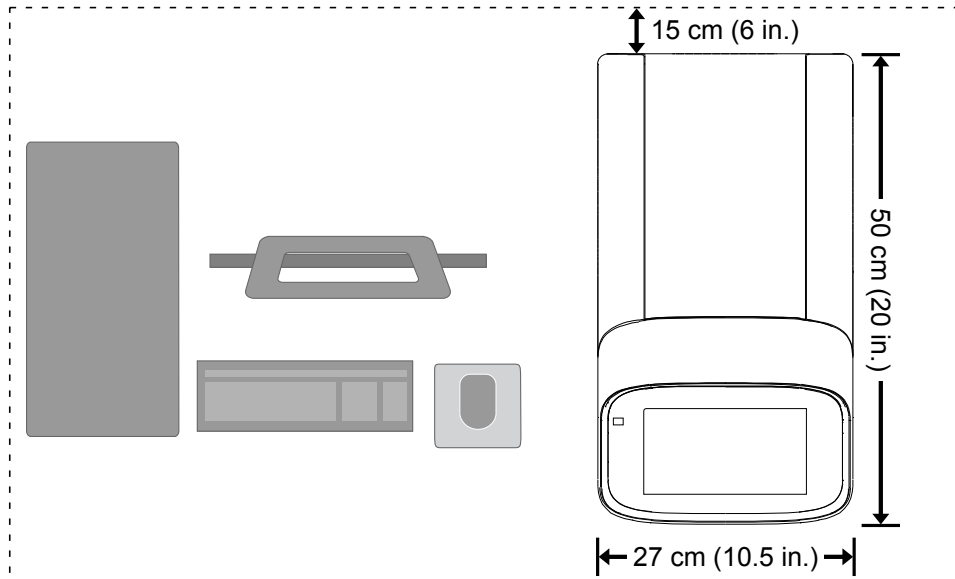

## Instrument and computer connections

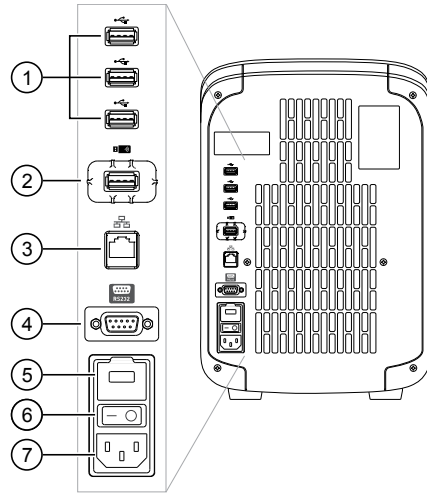

**Figure 4** Instrument back panel

- |   |                                   |
|---|-----------------------------------|
| ① USB ports   | ④ RS232 Port—For service use only |
| ② WiFi USB port—Not applicable  | ⑤ Fuse Cover                      |
| ③ Ethernet Port—RJ45 port for 100/1,000 Mbps Ethernet communication with the instrument | ⑥ Power Switch                    |
|   | ⑦ Power Port—100 to 240 VAC       |

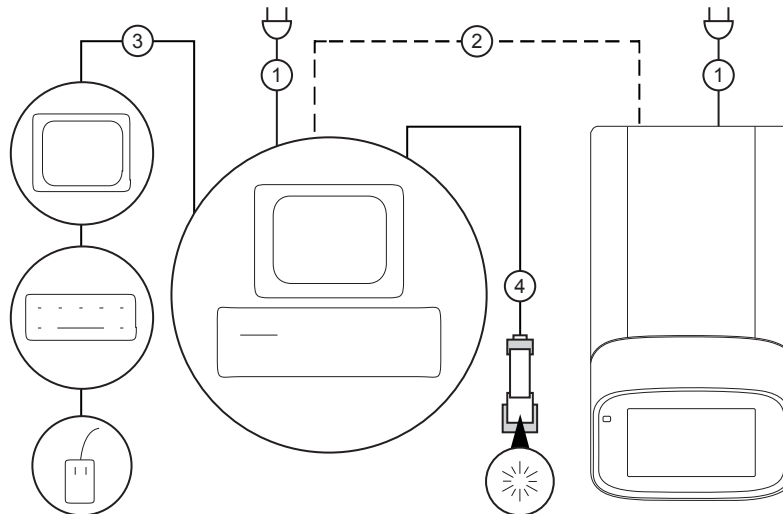

**Figure 5** Instrument-to-computer connections (minitower configuration)

- ① Detachable power supply cord compatible with local power supply receptacle.
- ② Connection between the computer and the instrument.
- ③ Connection between the computer and the monitor, keyboard, and mouse.
- ④ Connection between the computer and the *optional* handheld barcode scanner.

## Instrument clearances

During instrument installation and maintenance, it is necessary to access the back of the instrument. If the back of the instrument faces a wall, ensure that there is sufficient clearance on the bench to rotate the instrument for access.

---

**IMPORTANT!** For safety, the power outlet for the instrument must be accessible.

---

Component	Top	Front	Sides	Back
Instrument	30 cm (12 in.)	30 cm (12 in.)	15 cm (6 in.)	15 cm (6 in.)
Computer	—	15 cm (6 in.)	—	15 cm (6 in.)

## Electrical requirements



**WARNING!** For safety, the power outlet used for powering the instrument must be accessible at all times. See “Instrument clearances” for information about the space needed between the wall and the instrument. In case of emergency, you must be able to immediately disconnect the main power supply to all the equipment. Allow adequate space between the wall and the equipment so that the power cords can be disconnected in case of emergency.

- Electric receptacle with grounding capability
- Maximum power dissipation: ~960 W (not including computer and monitor)
- Mains AC line voltage tolerances must be up to  $\pm 10$  percent of nominal voltage

Device	Rated voltage	Circuit required	Rated frequency	Rated power
Instrument	100–240 $\pm 10\%$ VAC <sup>[1]</sup>	10 A	50/60 Hz	960 W
Computer (laptop)	100–240 $\pm 10\%$ VAC	10 A	50/60 Hz	90 VA
Computer (desktop)	100–240 $\pm 10\%$ VAC	10 A	50/60 Hz	125 VA
Monitor				65 VA

<sup>[1]</sup> If the supplied power fluctuates beyond the rated voltage, a power line regulator may be required. High or low voltages can adversely affect the electronic components of the instrument.





## Environmental requirements

Table 2 Environmental requirements

Condition	Acceptable range
Installation site	Indoor use only
Electromagnetic interference	Do not use this device in close proximity to sources of strong electromagnetic radiation (for example, unshielded intentional RF sources). Strong electromagnetic radiation may interfere with the proper operation of the device.
Altitude	Between sea level and 2000 m (6500 ft.) above sea level
Operating conditions	<ul style="list-style-type: none"> <li>Humidity: 15–80% relative humidity (noncondensing)</li> <li>Temperature: 15 to 30°C (59 to 86°F)</li> </ul> <p><b>Note:</b> For optimal performance, avoid rapid or extreme fluctuations in room temperature.</p>
Storage and transport conditions	<ul style="list-style-type: none"> <li>Humidity: 20–80% relative humidity (noncondensing)</li> <li>Temperature: –30 to 60°C (–22 to 140°F)</li> </ul>
Thermal output	During operation, the net thermal output, based on the actual current draw of the instrument, is expected to be approximately 960 W (3275 Btu/h).
Vibration	Ensure that the instrument is not adjacent to strong vibration sources, such as a centrifuge, pump, or compressor. Excessive vibration will affect instrument performance.
Pollution degree	<p>The instrument has a Pollution Degree rating of II. The instrument may only be installed in an environment that has nonconductive pollutants such as dust particles or wood chips. Typical environments with a Pollution Degree II rating are laboratories and sales and commercial areas.</p> <p>The noise output of the instrument is ≤ 60 dB when running.</p>
Other conditions	<p>Ensure the instrument is located away from any vents that could expel particulate material onto the instrument components.</p> <p>Avoid placing the instrument and computer adjacent to heaters, cooling ducts, or in direct sunlight.</p>



# Safety

■ Symbols on this instrument .....	67
■ Safety alerts on this instrument .....	69
■ Safety information for instruments not manufactured by Thermo Fisher Scientific .....	70
■ Instrument safety .....	70
■ Safety and electromagnetic compatibility (EMC) standards .....	72
■ Chemical safety .....	74
■ Biological hazard safety .....	75

---

 **WARNING! GENERAL SAFETY.** Using this product in a manner not specified in the user documentation may result in personal injury or damage to the instrument or device. Ensure that anyone using this product has received instructions in general safety practices for laboratories and the safety information provided in this document.

- Before using an instrument or device, read and understand the safety information provided in the user documentation provided by the manufacturer of the instrument or device.
  - Before handling chemicals, read and understand all applicable Safety Data Sheets (SDSs) and use appropriate personal protective equipment (gloves, gowns, eye protection, etc). To obtain SDSs, see the “Documentation and Support” section in this document.
-









## Symbols on this instrument



Symbols may be found on the instrument to warn against potential hazards or convey important safety information. In this document, the hazard symbol is used along with one of the following user attention words:

- **CAUTION!** – Indicates a potentially hazardous situation that, if not avoided, may result in minor or moderate injury. It may also be used to alert against unsafe practices.
- **WARNING!** – Indicates a potentially hazardous situation that, if not avoided, could result in death or serious injury.
- **DANGER!** – Indicates an imminently hazardous situation that, if not avoided, will result in death or serious injury.

Symbol	English	Français
	Caution, risk of danger Consult the manual for further safety information.	Attention, risque de danger Consulter le manuel pour d'autres renseignements de sécurité.
	Caution, risk of electrical shock	Attention, risque de choc électrique
	Moving parts	Parties mobiles
	Caution, hot surface	Attention, surface chaude
	Potential biohazard	Danger biologique potentiel
	Ultraviolet light	Rayonnement ultraviolet
	Potential slipping hazard	Danger de glisser potentiel
I	On	On (marche)
O	Off	Off (arrêt)
Ⓜ	On/Off	On/Off (marche/arrêt)
	Standby	En attente



Symbol	English	Français
	Earth (ground) terminal	Borne de (mise à la) terre
	Protective conductor terminal (main ground)	Borne de conducteur de protection (mise à la terre principale)
	Terminal that can receive or supply alternating current or voltage	Borne pouvant recevoir ou envoyer une tension ou un courant de type alternatif
	Terminal that can receive or supply alternating or direct current or voltage	Borne pouvant recevoir ou envoyer une tension ou un courant continu ou alternatif
	Do not dispose of this product in unsorted municipal waste   <b>CAUTION!</b> To minimize negative environmental impact from disposal of electronic waste, do not dispose of electronic waste in unsorted municipal waste. Follow local municipal waste ordinances for proper disposal provision and contact customer service for information about responsible disposal options.	Ne pas éliminer ce produit avec les déchets usuels non soumis au tri sélectif.   <b>CAUTION!</b> Pour minimiser les conséquences négatives sur l'environnement à la suite de l'élimination de déchets électroniques, ne pas éliminer ce déchet électronique avec les déchets usuels non soumis au tri sélectif. Se conformer aux ordonnances locales sur les déchets municipaux pour les dispositions d'élimination et communiquer avec le service à la clientèle pour des renseignements sur les options d'élimination responsable.

Conformity symbols

Conformity mark	Description
	Indicates conformity with safety requirements for Canada and U.S.A.
	Indicates conformity with European Union requirements for safety and electromagnetic compatibility.
	Indicates conformity with Australian standards for electromagnetic compatibility.

## Safety alerts on this instrument

Additional text may be used with one of the symbols described above when more specific information is needed to avoid exposure to a hazard. See the following table for safety alerts found on the instrument.

English	French translation
 <b>CAUTION! Hazardous chemicals.</b> Read the Safety Data Sheets (SDSs) before handling.	<b>ATTENTION! Produits chimiques dangereux.</b> Lire les fiches signalétiques (FS) avant de manipuler les produits.
 <b>CAUTION! Hazardous waste.</b> Refer to SDS(s) and local regulations for handling and disposal.	<b>ATTENTION! Déchets dangereux.</b> Lire les fiches signalétiques (FS) et la réglementation locale associées à la manipulation et à l'élimination des déchets.

### Location of safety labels on the instrument

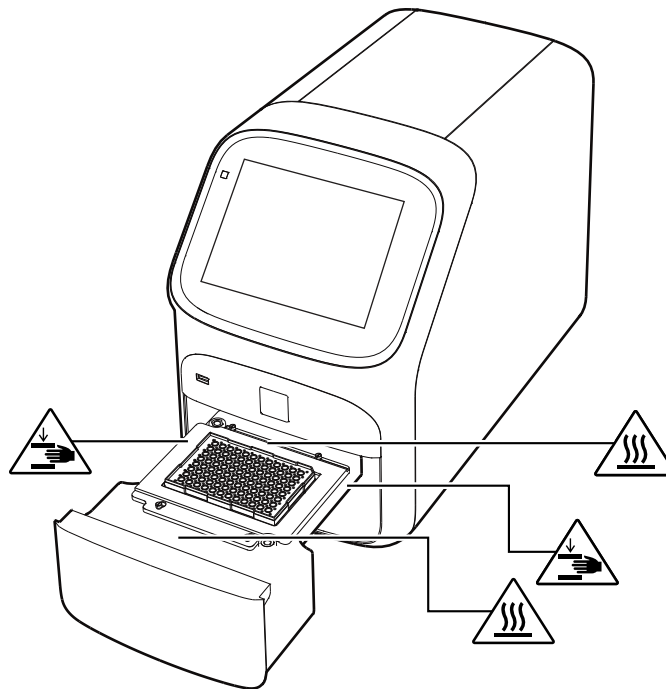

## Safety information for instruments not manufactured by Thermo Fisher Scientific

Some of the accessories provided as part of the instrument system are not designed or built by Thermo Fisher Scientific. Consult the manufacturer's documentation for the information needed for the safe use of these products.

### Instrument safety

#### General



**CAUTION! Do not remove instrument protective covers.** If you remove the protective instrument panels or disable interlock devices, you may be exposed to serious hazards including, but not limited to, severe electrical shock, laser exposure, crushing, or chemical exposure.

---



**CAUTION! Solvents and Pressurized fluids.** Wear eye protection when working with any pressurized fluids. Use caution when working with any polymeric tubing that is under pressure:

- Extinguish any nearby flames if you use flammable solvents.
  - Do not use polymeric tubing that has been severely stressed or kinked.
  - Do not use polymeric tubing with tetrahydrofuran or nitric and sulfuric acids.
  - Be aware that methylene chloride and dimethyl sulfoxide cause polymeric tubing to swell and greatly reduce the rupture pressure of the tubing.
  - Be aware that high solvent flow rates (~40mL/min) may cause a static charge to build up on the surface of the tubing and electrical sparks may result.
-

## Physical injury



**CAUTION! Moving and Lifting Injury.** The instrument is to be moved and positioned only by the personnel or vendor specified in the applicable site preparation guide. Improper lifting can cause painful and permanent back injury.

Things to consider before lifting or moving the instrument or accessories:

- Depending on the weight, moving or lifting may require two or more persons.
- If you decide to lift or move the instrument after it has been installed, do not attempt to do so without the assistance of others, the use of appropriate moving equipment, and proper lifting techniques.
- Ensure you have a secure, comfortable grip on the instrument or accessory.
- Make sure that the path from where the object is to where it is being moved is clear of obstructions.
- Do not lift an object and twist your torso at the same time. Keep your spine in a good neutral position while lifting with your legs.
- Participants should coordinate lift and move intentions with each other before lifting and carrying.
- For smaller packages, rather than lifting the object from the packing box, carefully tilt the box on its side and hold it stationary while someone else slides the contents out of the box.



**CAUTION! Moving Parts.** Moving parts can crush, pinch and cut. Keep hands clear of moving parts while operating the instrument. Disconnect power before servicing.



**WARNING!** Do not attempt to lift or move the instrument without the assistance of others. Use appropriate moving equipment and proper lifting technique, improper lifting may result in serious injury.

---

## Electrical



---

**WARNING! Fuse Installation.** Before installing the instrument, verify that the fuses are properly installed and the fuse voltage matches the supply voltage. Replace fuses only with the type and rating specified for the unit. Improper fuses can damage the instrument wiring system and cause a fire.

---



---

**WARNING! Ensure appropriate electrical supply.** For safe operation of the instrument:

- Plug the system into a properly grounded receptacle with adequate current capacity.
  - Ensure the electrical supply is of suitable voltage.
  - Never operate the instrument with the ground disconnected. Grounding continuity is required for safe operation of the instrument.
- 



---

**WARNING! Power Supply Line Cords.** Use properly configured and approved line cords for the power supply in your facility.

---



---

**WARNING! Disconnecting Power.** To fully disconnect power either detach or unplug the power cord, positioning the instrument such that the power cord is accessible.

---

## Cleaning and decontamination



---

**CAUTION! Cleaning and Decontamination.** Use only the cleaning and decontamination methods specified in the manufacturer's user documentation. It is the responsibility of the operator (or other responsible person) to ensure the following requirements are met:

- No decontamination or cleaning agents are used that could cause a HAZARD as a result of a reaction with parts of the equipment or with material contained in the equipment.
  - The instrument is properly decontaminated a) if hazardous material is spilled onto or into the equipment, and/or b) prior to having the instrument serviced at your facility or sending the instrument for repair, maintenance, trade-in, disposal, or termination of a loan (decontamination forms may be requested from customer service).
  - Before using any cleaning or decontamination methods (except those recommended by the manufacturer), users should confirm with the manufacturer that the proposed method will not damage the equipment.
- 

## Safety and electromagnetic compatibility (EMC) standards

The instrument design and manufacture complies with the standards and requirements for safety and electromagnetic compatibility as noted in the following table:



## Safety compliance

Reference	Description
EU Directive 2014/35/EU	European Union “Low Voltage Directive”
IEC 61010-1 EN 61010-1 UL 61010-1 CSA C22.2 No. 61010-1	<i>Safety requirements for electrical equipment for measurement, control, and laboratory use – Part 1: General requirements</i>
IEC 61010-2-010 EN 61010-2-010	<i>Safety requirements for electrical equipment for measurement, control and laboratory use – Part 2-010: Particular requirements for laboratory equipment for the heating of materials</i>
IEC 61010-2-081 EN 61010-2-081	<i>Safety requirements for electrical equipment for measurement, control and laboratory use – Part 2-081: Particular requirements for automatic and semi-automatic laboratory equipment for analysis and other purposes</i>

## EMC

Reference	Description
Directive 2014/30/EU	European Union “EMC Directive”
EN 61326-1/ IEC 61326-1	<i>Electrical Equipment for Measurement, Control and Laboratory Use – EMC Requirements – Part 1: General Requirements</i>
AS/NZS CISPR 11	<i>Limits and Methods of Measurement of Electromagnetic Disturbance Characteristics of Industrial, Scientific, and Medical (ISM) Radiofrequency Equipment</i>
ICES-001, Issue 4	<i>Industrial, Scientific and Medical (ISM) Radio Frequency Generators</i>
FCC Part 15 Subpart B (47 CFR)	<i>U.S. Standard Radio Frequency Devices</i>

This equipment has been tested and found to comply with the limits for a Class A digital device, pursuant to part 15 of the FCC Rules. These limits are designed to provide reasonable protection against harmful interference when the equipment is operated in a commercial environment. This equipment generates, uses, and can radiate radio frequency energy and, if not installed and used in accordance with the instruction manual, may cause harmful interference to radio communications. Operation of this equipment in a residential area is likely to cause harmful interference in which case the user will be required to correct the interference at his own expense.

## Environmental design

Reference	Description
Directive 2012/19/EU	European Union "WEEE Directive" – Waste electrical and electronic equipment
Directive 2011/65/EU	European Union "RoHS Directive" – Restriction of hazardous substances in electrical and electronic equipment
Directive 2006/66/EC	European Union "Battery Directive"

## Chemical safety

- 
-  **WARNING! GENERAL CHEMICAL HANDLING.** To minimize hazards, ensure laboratory personnel read and practice the general safety guidelines for chemical usage, storage, and waste provided below, and consult the relevant SDS for specific precautions and instructions:
- Read and understand the Safety Data Sheets (SDSs) provided by the chemical manufacturer before you store, handle, or work with any chemicals or hazardous materials. To obtain SDSs, see the "Documentation and Support" section in this document.
  - Minimize contact with chemicals. Wear appropriate personal protective equipment when handling chemicals (for example, safety glasses, gloves, or protective clothing).
  - Minimize the inhalation of chemicals. Do not leave chemical containers open. Use only with adequate ventilation (for example, fume hood).
  - Check regularly for chemical leaks or spills. If a leak or spill occurs, follow the manufacturer's cleanup procedures as recommended in the SDS.
  - Handle chemical wastes in a fume hood.
  - Ensure use of primary and secondary waste containers. (A primary waste container holds the immediate waste. A secondary container contains spills or leaks from the primary container. Both containers must be compatible with the waste material and meet federal, state, and local requirements for container storage.)
  - After emptying a waste container, seal it with the cap provided.
  - Characterize (by analysis if necessary) the waste generated by the particular applications, reagents, and substrates used in your laboratory.
  - Ensure that the waste is stored, transferred, transported, and disposed of according to all local, state/provincial, and/or national regulations.
  - **IMPORTANT!** Radioactive or biohazardous materials may require special handling, and disposal limitations may apply.
- 

 **WARNING! HAZARDOUS WASTE (from instruments).** Waste produced by the instrument is potentially hazardous. Follow the guidelines noted in the preceding General Chemical Handling warning.

---

 **WARNING! 4L Reagent and Waste Bottle Safety.** Four-liter reagent and waste bottles can crack and leak. Each 4-liter bottle should be secured in a low-density polyethylene safety container with the cover fastened and the handles locked in the upright position.

---

## Biological hazard safety



**WARNING! Potential Biohazard.** Depending on the samples used on this instrument, the surface may be considered a biohazard. Use appropriate decontamination methods when working with biohazards.

---



**WARNING! BIOHAZARD.** Biological samples such as tissues, body fluids, infectious agents, and blood of humans and other animals have the potential to transmit infectious diseases. All work should be conducted in properly equipped facilities using the appropriate safety equipment (for example, physical containment devices). Safety equipment also may include items for personal protection, such as gloves, coats, gowns, shoe covers, boots, respirators, face shields, safety glasses, or goggles. Individuals should be trained according to applicable regulatory and company/ institution requirements before working with potentially biohazardous materials. Follow all applicable local, state/provincial, and/or national regulations. The following references provide general guidelines when handling biological samples in laboratory environment.

- U.S. Department of Health and Human Services, *Biosafety in Microbiological and Biomedical Laboratories (BMBL)*, 5th Edition, HHS Publication No. (CDC) 21-1112, Revised December 2009; found at:  
[www.cdc.gov/biosafety/publications/bmb15/BMBL.pdf](http://www.cdc.gov/biosafety/publications/bmb15/BMBL.pdf)
  - World Health Organization, *Laboratory Biosafety Manual*, 3rd Edition, WHO/CDS/CSR/LYO/2004.11; found at:  
[www.who.int/csr/resources/publications/biosafety/Biosafety7.pdf](http://www.who.int/csr/resources/publications/biosafety/Biosafety7.pdf)
-

# Documentation and support

## Related documentation

Document	Pub. No.
<i>QuantStudio™ 5 Real-Time PCR Instrument Site Preparation Guide (for Human Identification)</i>	MAN0016701
<i>QuantStudio™ 5 Real-Time PCR Instrument User Guide (for Human Identification)</i>	MAN0017162
<i>HID Real-Time PCR Analysis Software v1.3 User Guide</i>	MAN0009819

## Obtain information from the Help system

The instrument has a Help system that describes how to use each feature of the touchscreen. Touch  on the instrument touchscreen to access the Help system.

## Customer and technical support

For support:

- **In North America**—Send an email to [HIDTechSupport@thermofisher.com](mailto:HIDTechSupport@thermofisher.com), or call 888-821-4443 option 1.
- **Outside North America**—Contact your local support office.
- For latest services and support information for all locations, go to [thermofisher.com/support](http://thermofisher.com/support).

## Limited product warranty

Life Technologies Corporation and/or its affiliate(s) warrant their products as set forth in the Life Technologies' General Terms and Conditions of Sale found on Life Technologies' website at [www.thermofisher.com/us/en/home/global/terms-and-conditions.html](http://www.thermofisher.com/us/en/home/global/terms-and-conditions.html). If you have any questions, please contact Life Technologies at [www.thermofisher.com/support](http://www.thermofisher.com/support).

# Index

## A

accessories 60  
administrator instrument profile 27

## B

background calibration  
    create plate 40  
    description 35  
    plate, prepare 37, 41  
    run 38  
    when to perform 34  
backup instrument 48  
biohazard safety 75

## C

calibration  
    background 38  
    custom dye. *See* custom dye  
    dye 38  
    plate, prepare 37, 41  
    reminders 36  
    ROI/uniformity 38  
    schedule 34  
    status 36  
    transfer results 39  
    view images 39  
    workflow 36  
calibration failure, troubleshoot 56  
computer  
    connection to instrument or LAN 17  
    connections 16, 63  
consumables, 96-well 0.2-mL 59  
contamination, identify 40  
custom dye  
    add to the instrument 42  
    calibration, perform 42  
    description 10  
custom dye calibration, workflow, HID 41  
custom dyes, HID-validated workflow 41

## D

date and time 30  
disk space message  
documentation, related 76  
dye calibration  
    description 35  
    plate, prepare 37, 41  
    run 38  
    when to perform 34  
dyes  
    custom 10  
    system 9

## E

EDS files, transfer 22

## F

factory defaults 31  
firewall ports 17  
fluorescence high  
fuses, replace 52

## G

guest profile, disable 29

## H

heated cover temperature, set for instrument idling  
    30  
Help system, access 76  
home screen, parts of 11

## I

installation  
    before you begin 14  
    workflow 14  
instrument  
    profile, create 28  
    avatar 29  
    connections 16, 63

- enable for remote monitoring 31
- heated cover idle temperature 30
- move 53
- name 29
- overview 7
- parts of 10
- power off 19
- power on 19
- prepare to store or move or ship 53
- profile, overview 27
- return for service 54
- touchscreen black

instrument filters 9

instrument layout 61

instrument settings 24, 26

instrument specification 61

instrument verification. *See* RNase P verification

## L

- limited product warranty 76
- load plate 21

## M

- maintenance 48

## N

- network, configurations supported 17

## O

- online Help. *See* Help system

## P

- performance verification. *See* RNase P verification
- PIN reset 28
- profiles
  - administrator 27
  - delete 28
  - edit 28
  - guest, disable 29
  - instrument 28
  - require sign-in 29
  - reset PIN 28
  - sign in 20

## R

- real-time plots
  - view on instrument touchscreen 22
  - zoom 22

- related documentation 76
- Replace with index term
- require sign in 29
- restore instrument 48
- RNase P verification
  - pass criteria 45
  - plate description 45
  - plate, prepare 46
  - run 47
- ROI/uniformity calibration
  - description 35
  - plate, prepare 37, 41
  - run 38
  - when to perform 34
- run data, transfer 22

## S

- safety, biohazard 75
- sample block
  - clean 49
  - decontaminate 49
- settings 24, 26
- sign in, require 29
- sign out
  - profile 20
  - timer, set 29
- sleep mode 30
- software updates 32
- standby mode 30
- startup wizard 15
- supported dyes 9
- symbols, safety 67
- system dyes 9

## T

- terms and conditions 76
- troubleshooting 55

## U

- uniformity calibration
  - description 35
  - plate, prepare 37, 41
  - run 38
  - when to perform 34
- unload plate 21
- unpack instrument 15

## V

- verification failure, troubleshoot 57

**W**

- warranty 76
- well details, view on instrument touchscreen 22
- workflow, custom dye calibration, HID 41

**Z**

- zoom 22

