



B. Braun OMNI® Troubleshooting Guide

SW version 1.75.10



Contents page

Operation with integrated battery (4.6.1)	4
Description of the alarm system (8.1.0)	4
Protective alarm system (8.1.1)	4
Alarm priorities (8.1.2)	4
How to display further information on an alarm	5
Touch screen failure	5
Preparing machine for treatment (5.0.0)	5
Loading the disposable kit (5.5.1)	5
Installing the bags (5.6.1)	6
Setting the parameters (5.10.0)	6
Alarms during preparation (8.3.2)	6
Low venous pressure (8.3.2.1)	6
High arterial pressure (8.3.2.2) and low arterial pressure (8.3.2.3)	7
Blood leak detector test failed (8.4.0)	7
Blood pump failure (8.3.2.4)	8
Empty priming bag (8.3.2.5)	8
Net fluid removal alarms (8.3.3.4)	9
Alarms during therapy (8.3.3)	10
Low venous pressure (8.3.3.6)	10
High venous pressure (8.4.0)	11
Frozen venous pressure (8.4.0)	12
High arterial pressure (8.3.3.7)	13
Low arterial pressure (8.3.3.8)	13
Blood in the arterial pressure line (8.3.3.8b)	14
High pre-filter pressure (8.3.3.9)	14
High filter drop pressure (8.4.0)	15
High transmembrane pressure (8.3.3.10)	15
High effluent pressure (8.3.3.11)	16
Low solution pressure (8.3.3.12)	16
Blood leak detected in effluent line (8.3.3.13)	17
Removing air from venous line (8.3.3.14)	18
Removing air from calcium line (8.3.3.15)	19
Warmer door open (8.4.0)	20
Internal alarms (8.4.0)	21
Manual blood return	21
Additional resources	21
Arterial and venous pressure troubleshooting	22
Notes	23

This troubleshooting guide is linked to the OMNI® IFU SW 1.75.10 and should be used as an additional tool alongside the IFU, the set-up guide and appropriate training. Always refer to the IFU for full instructions., corresponding chapters can be found in parentheses.



— Always keep the OMNI® plugged in, even when not in use.



— If the OMNI® doesn't turn on, allow it to charge and retry later.



— To switch the OMNI® on, briefly press and release the green power button, do not press and hold the button or press multiple times as this will power the machine off or reboot it.



— The OMNI® battery should last approximately 30 minutes from being fully charged.

Operation with integrated battery (4.6.1)

The OMNI® is equipped with a backup battery which, in case of power failure, ensures blood circulation. The backup battery has the following functions when the machine is disconnected from mains supply.

- Supply of the control system and safety components
- Supply of the blood side pumps
- Supply of the touch screen

Due to the limited capacity of the backup battery, the following components are deactivated when the machine is disconnected from the mains supply:

- Fluid side pumps
- Warmer

Description of the alarm system (8.1.0)

When the machine detects a critical situation, an alarm is generated. The machine signals the alarm with the highest priority based on the priority level and the internal ranking of the conditions. The machine ensures the necessary safe state of the patient. Depending on the alarm, this can be e.g., the stopping of certain pumps, the deactivation of the warmer or the closing of the venous clamp.

Protective alarm system (8.1.1)

The machine is equipped with a secondary alarm system called **protective alarm system**, which monitors the operation of the primary alarm system and generates separate alarms if necessary.

Alarm priorities (8.1.2)

If multiple alarms are present at the same time, the **five** alarms with the highest ranking can be displayed by pressing the pop-up dialogue box displaying the alarm on the bottom left side of the touch screen. The priority levels of alarms are fixed with the following exceptions:

- Long stop of blood pump
- Long stop of fluid side pumps
- Long stop of anticoagulation pump

These alarms are changed to a warning instead of an alarm when they are reset. The condition is then still visible as a warning. All other alarms are visible on the touch screen for the user to resolve.

How to display further information on an alarm

- Press the currently displayed alarm in the bottom left area or warning in the bottom right area of the touch screen.
 - The list of alarms or warnings appears.
- Press the  symbol at the right edge of the alarm or warning.
 - An information screen with remedial measures to remove the alarm condition is displayed.

This guidance is in accordance with the IFU.

Touch screen failure

In case of display or touch screen failure, all control and protective functions remain active.

It is recommended to pause treatment by pressing the **STOP** key on the monitor and thus stopping all pumps. The machine automatically attempts to recover the touch screen functionality. If the touch screen failure still persists after a minute, restart the machine.

Preparing machine for treatment (5.0.0)

Loading the disposable kit (5.5.1):

- 1 Make sure that no lines are stuck between the kit and the machine when loading the disposable kit. Press disposable kit sides firmly into the locks until you hear the locking mechanism click. Make sure that both upper and lower locks are engaged. Make sure that the pins used to unload the kit are behind the green plate and not exposed.
- 2 Ensure the warmer door is properly locked and do not reopen it after priming.
- 3 Make sure that the used syringe solution is according to prescription.
- 4 In case of regional citrate anticoagulation, make sure that the concentration of the used calcium and citrate solution matches with the displayed value.
- 5 Make sure the syringe is connected to the appropriate line.
- 6 Make sure the manual clamps on all used lines are open and all unused lines are closed.
- 7 When inserting the syringe, position the piston plate into the clip and the gripping plate into the slot - the clasp nut should close automatically. There is a possibility that the syringe will not be loaded if the clasp nut does not automatically close.

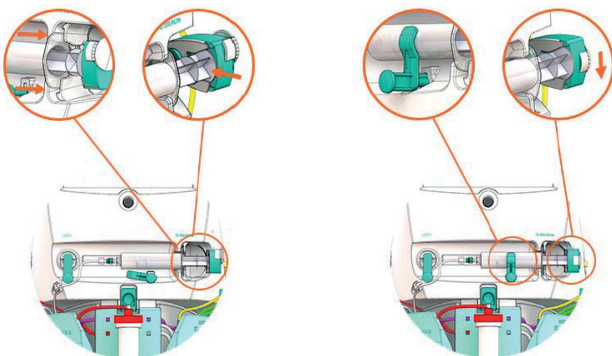

- 8 When using calcium, ensure the calcium line is pushed to the back of the air detector.
- 9 Make sure that the tube segments are loaded correctly by opening the magnetic blood and fluid side doors. In case of unsuccessful loading, press Load again.

Preparing machine for treatment (5.0.0)

Installing the bags (5.6.1):

- 1 Make sure that the used solutions and parameters are according to prescription.
- 2 Make sure that the line clamps are **closed** on all lines that are **not** being utilised.
- 3 Make sure that the line clamps are **open** on all lines that **are** being utilised.
- 4 Make sure that each bag has been put on the correct load cell and is connected to the correct line.
- 5 Do not hang anything other than the fluid bags intended for the therapy on the load cells (this includes cables and lines). Use the tube holders to secure lines.

Setting the parameters (5.10.0):

The duration of a therapy can be limited. As default, the duration of a therapy is set to the maximum time of 240 hours. This setting may be changed by modifying the therapy time limit. Do not input a **Therapy Time Limit** unless you wish to limit the length of the therapy. If you accidentally input a therapy time limit and the machine alarms, it is possible to edit the therapy time limit to extend the treatment.

Alarms during preparation (8.3.2)

Below is a description of possible causes and remedies of the most common critical alarms that may occur during preparation.

Low venous pressure (8.3.2.1)

- 1 Venous line (blue) may not be properly connected to the waste bag.
- 2 Possible leakage on venous line (blue).
- 3 Possible pressure measurement error.
 - Make sure that the pressure lines and pressure ports are connected, and no fluid reaches the pressure line filter.
 - Replace kit if fluid has reached the pressure line filter.
- 4 Venous line (blue) may be connected to the wrong bag.

Tips

Always extend IV pole as high as it will go.

When connecting the patient via White Connection, ensure the Fill Blood Lines button is used and do not enter Therapy until the Delivered Volume is the total circuit volume.

Alarms during preparation (8.3.2)

High arterial pressure (8.3.2.2) and low arterial pressure (8.3.2.3)

1 Arterial line (red) may not be properly connected to the saline bag and/or priming bag.

2 Arterial line (red) may be occluded.

3 Possible leakage on arterial line (red).

4 Possible pressure measurement error.

Make sure that the pressure lines and pressure ports are connected, and no fluid reaches the pressure line filter.

Replace kit if fluid has reached the pressure line filter.

5 Arterial line (red) may be connected to the wrong bag.

Check that the arterial line is connected to the saline bag on centre load cell.

Tips

You will not see an hourglass or generate a tick when you attach the pressure lines during Install the Kit, this will be tested when you proceed to the following screen.

Ensure spikes are pushed far enough into the saline bags.

Ensure all used lines are unclamped.

Ensure that any spikes used do not have bio-connectors attached as these will cause low pressure alarms.

Blood leak detector test failed (8.4.0)

1 The disposable kit may not be installed properly.

2 Make sure that the disposable kit is properly loaded, and the tube segment is all the way in the blood leak detector.

Tips

Apply pressure over the BLD (below the effluent chamber) to reduce any light leaks between the BLD on the OMNI® and the black sponge in the disposable kit.

Alarms during preparation (8.3.2)

Blood pump failure (8.3.2.4)

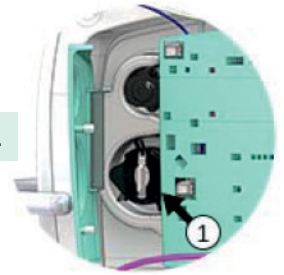

1 Blood pump rotation error: The blood pump segment of the disposable kit may not be loaded properly.

Check pump segment and make sure it is loaded properly into the blood pump.

Tips

Press load again if the tube segment doesn't load the first time. If this doesn't work, manually load the tube segment by hand and then press load to complete the process.

Ensure that the grey lever on the blood pump is securely fitted into the pump.

If the blood pump is not correctly fitted to the OMNI®, the following alarm can occur during the therapy: Blood side door open (O10). Ensure that the pump is correctly fitted and then close the door and reset alarms.

Empty priming bag (8.3.2.5)

1 Arterial line (red) may not be properly connected to the saline bag and/or priming bag may not be opened correctly.

2 Priming bag may be empty.

3 Possible leakage on arterial line (red).

4 Possible pressure measurement error.

Make sure that the pressure lines and pressure ports are connected and no fluid reaches the pressure line filter.

Replace kit if fluid has reached the pressure line filter.

Tips

Ensure that any spikes used do not have bio-connectors attached as these will cause low pressure alarms.

Alarms during preparation (8.3.2)

Below is a description of possible causes and remedies of the most common critical alarms that may occur during therapy.

Net fluid removal alarms (8.3.3.4)

During treatment, the OMNI® continuously measures the weight of the dialysate bag, substitution fluid bag, citrate bag and effluent bag. Based on the weight changes measured on the load cells and the volume of anticoagulant and fluids delivered by the pumps, the machine calculates the volume of fluid actually removed from the patient at a given time.

If the difference between the target volume and actually removed volume exceeds a given initial alarm limit, the machine issues an alarm. In case the volume error persists, and the deviation reaches an absolute alarm limit, the alarm can no longer be reset.

Alarm limit	Value
Initial alarm limit	±90 g
Alarm limit step after alarm reset	±10 g
Absolute alarm limit	±180 g

Tips

Bag(s) may not be open. Make sure that the bag outlets are open and properly connected. Also check bags for leaks.

Bag(s) may have been changed without confirmation. Make sure that each bag change has been confirmed. Press the Bags button and then select 'Bag Change/Weight Reset'.

Pump segment(s) may not be loaded properly to the corresponding pump(s). Check if pump segments are correctly loaded into the pumps.

Ensure that nothing else sits on the scale such as a mains cable or line.

If the alarm still persists, the maximum error limit is reached. Therapy cannot be continued, proceed to end of therapy. Do not select 'Change Kit'.

Alarms during therapy (8.3.3)

Low venous pressure (8.3.3.6)

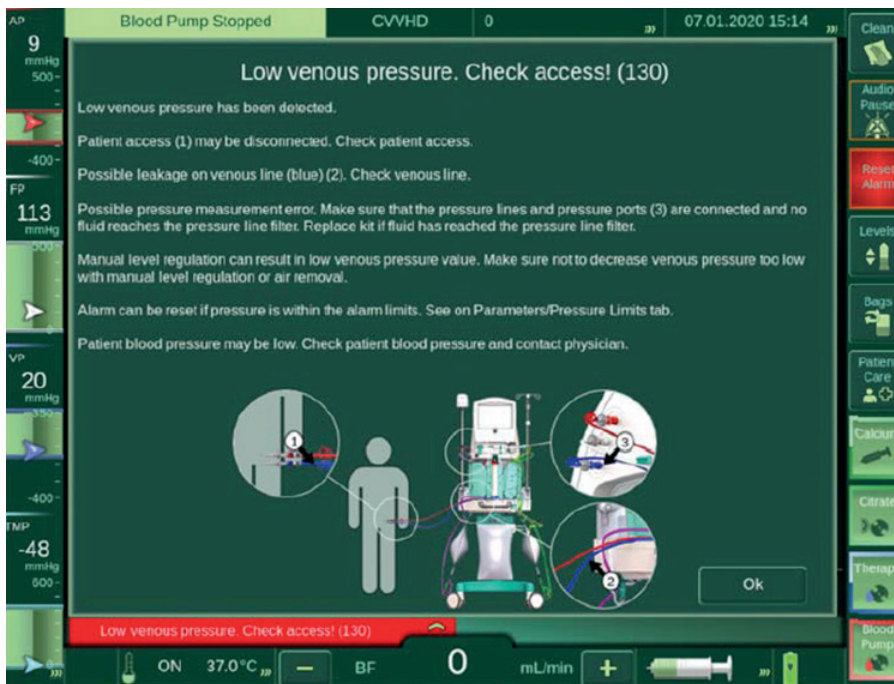

1 Patient access may be disconnected.

2 Possible leakage on venous line (blue).

3 Possible pressure measurement error.

Make sure that the pressure lines and pressure ports are connected, and no fluid reaches the pressure line filter.

Replace kit if fluid has reached the pressure line filter.

4 Manual level regulation can result in low venous pressure value.

Make sure not to decrease venous pressure too low with manual level regulation or air removal.

5 Patient blood pressure may be low.

Check patient blood pressure and contact physician.

Alarms during therapy (8.3.3)

Tips

Check patient fluid status and contact a physician if maintenance or bolus IV is required.

Increase the height of the bed if it is safe to do so.

Blood flow rate may be too low.

Increase blood flow rate if safe to do so, in accordance with protocol, and contact physician.

Leave the Venous Chamber in Automatic Regulation.

High venous pressure (8.4.0)

1 Patient access or venous line (blue) may be blocked.

Check patient access and position and venous line.

2 Possible pressure measurement error.

Make sure that the pressure lines and pressure ports are connected and no fluid reaches the pressure line filter.

Replace kit if fluid has reached the pressure line filter.

3 Blood flow rate may be too high.

Decrease blood flow rate if safe to do so, in accordance with protocol, and contact physician.

4 Clots may have formed in the venous chamber.

Check for clots in chamber.

Consider changing the kit or modifying anticoagulation parameters and contact physician.

5 Automatic/Manual level regulation can result in high venous pressure value.

Make sure not to increase venous pressure too high with manual level regulation or air removal.

6 Reduce pressure using the infusion port on the venous chamber. Alarm can be reset if pressure is within the alarm limits (see frozen venous pressure).

Alarms during therapy (8.3.3)

Frozen venous pressure (8.4.0)

- 1 In case of a high venous pressure alarm, even if the root cause of the alarm has been solved, the alarm can only be reset if the venous pressure falls below 350 mmHg.
- 2 Do not press the blood pump or the therapy button.
- 3 Make sure that the hydrophobic filter on the venous pressure sensor is dry.
- 4 To release the high venous pressure within the circuit, locate the infusion port of the venous chamber with the blue clamp and blue cap.
- 5 Ensure the blue clamp is closed. Remove the blue cap.
- 6 Connect the infusion port to a 20 - 50 ml syringe with a fully inserted plunger.
- 7 Open the blue clamp for 1-2 seconds to release the pressure into the syringe.
 - The plunger will be pushed out automatically.
 - Close the blue clamp when the plunger reaches approximately 10 - 15 ml.
 - Check the venous pressure displayed on the screen. If it is still above 350 mmHg, open the blue clamp again to release the pressure into the syringe.
- 8 Close the blue clamp once the venous pressure has fallen below 350 mmHg and disconnect the syringe.
- 9 Reset the alarm.
- 10 The blood pump will restart automatically, releasing the venous clamp.
- 11 In case there is blood in the syringe, discard.
- 12 In case there is blood in the infusion port, enter patient care mode and slowly infuse 10 - 15 ml of normal saline.
- 13 Any air infused into the venous chamber will automatically be removed by the automatic level regulation feature.
- 14 Close the blue clamp and disconnect the syringe. Add the cap. Turn off patient care mode.

Alarms during therapy (8.3.3)

High arterial pressure (8.3.3.7)

1 Possible pressure measurement error.

Make sure that the pressure lines and pressure ports are connected, and no fluid reaches the pressure line filter.

Replace kit if fluid has reached the pressure line filter.

2 Patient blood pressure may be high.

Check patient blood pressure and contact physician.

3 Blood flow rate may be too low.

Increase blood flow rate if safe to do so in accordance with protocol and contact physician.

Replace kit if fluid has reached the pressure line filter.

Tips

High arterial pressure is uncommon. Ensure vascular access is sited in the correct vessel.

Low arterial pressure (8.3.3.8)

1 Patient access may be occluded.

2 Arterial line (red) may be occluded.

3 Possible pressure measurement error.

Make sure that the pressure lines and pressure ports ③ are connected and no fluid reaches the pressure line filter.

Replace kit if fluid has reached the pressure line filter.

4 Patient blood pressure may be low.

Check patient blood pressure and contact physician.

Alarms during therapy (8.3.3)

Blood in the arterial pressure line (8.3.3.8b)

Mandatory step:

After the alarm situation is resolved, check the arterial pressure line ④. In case the blood level has risen above the kit plate in the arterial pressure line ④ enter Patient Care Mode, clamp the arterial line at patient access ⑥ and disconnect the pressure line ⑤ from the pressure port ③. Reset the alarm and wait until the blood pump removes the blood from the pressure line. Reconnect the pressure line ⑤ back to the port ③ and immediately unclamp the arterial line ⑥ and switch off Patient Care Mode.

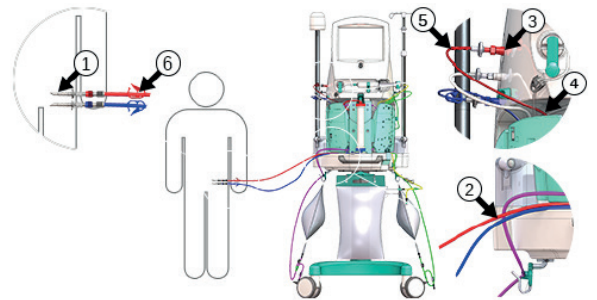

Tips

If blood clots have formed in the arterial pressure line it is not possible to remove them, and they may migrate into the pre-filter chamber after automatic regulation and lead to global clotting within the circuit. If the clots fully occlude the line, squash/flatten them to allow air to continue to move past so that a pressure measurement can be determined.

High pre-filter pressure (8.3.3.9)

- 1 Possible pressure measurement error.
 - Make sure that the pressure lines and pressure ports are connected, and no fluid reaches the pressure line filter.
 - Replace kit if fluid has reached the pressure line filter.
- 2 Manual clamp (blue) may be closed on filter line.
 - Open the clamp.
- 3 Clots may have formed in the filter.
 - Consider modifying anticoagulation parameters and contact physician.
 - If necessary, temporarily increase the alarm limit.
 - Alternatively, consider decreasing net fluid removal rate or blood flow or increasing pre-dilution (if applicable).
 - If the problem still persists, consider rinsing the kit during temporary patient disconnection or change the kit.
- 4 Blood flow rate may be too high.
 - Decrease blood flow rate if safe to do so, in accordance with protocol, and contact physician.
- 5 Manual level regulation can result in high pre-filter pressure value.
 - Make sure not to increase pre-filter pressure too high with manual level regulation.
- 6 Venous pressure may be high.
 - Check patient access (see High Venous Pressure).

Alarms during therapy (8.3.3)

High filter drop pressure (8.4.0)

- 1 Possible venous pressure drop.
 - Check venous patient access.
- 2 Possible blockage in the kit.
 - Check blood lines for kinks.
- 3 Manual clamp (blue) may be closed on filter line. Open it.
- 4 Possible pressure measurement error.
 - Make sure that the pressure lines and pressure ports are connected, and no fluid reaches the pressure line filter.
 - Replace kit if fluid has reached the pressure line filter.
- 5 Clots may have formed in the filter.
 - Consider modifying anticoagulation parameters and contact physician.
 - If necessary, temporarily increase the alarm limit.
 - Alternatively, consider decreasing net fluid removal rate or blood flow or increasing pre-dilution (if applicable).
 - If problem still persists, consider rinsing the kit during temporary patient disconnection or change the kit.

High transmembrane pressure (8.3.3.10)

- 1 Possible blockage in the kit.
 - Check lines for kinks.
- 2 Possible pressure measurement error.
 - Make sure that the pressure lines and pressure ports are connected, and no fluid reaches the pressure line filter.
 - Replace kit if fluid has reached the pressure line filter.
- 3 Clots may have formed in the filter.
 - Consider modifying anticoagulation parameters and contact physician.
 - Alternatively, consider decreasing net fluid removal rate or blood flow or increasing pre-dilution (if applicable).
 - If problem still persists, consider rinsing the kit during temporary patient disconnection or change the kit.

Alarms during therapy (8.3.3)

High effluent pressure (8.3.3.11)

- 1 The effluent line may be obstructed.
- 2 The venous line may be obstructed.
- 3 Possible pressure measurement error.
 - Make sure that the pressure lines and pressure ports are connected, and no fluid reaches the pressure line filter.
 - Replace kit if fluid has reached the pressure line filter.
- 4 Manual level regulation can result in high effluent pressure value error.
 - Make sure not to increase effluent pressure too high with manual level regulation.

Low solution pressure (8.3.3.12)

- 1 Dialysate/substitution fluid line (green) may be blocked.
 - Check dialysate/substitution fluid line (green) to solution bag on right load cell ① are connected, and no fluid reaches the pressure line filter.
 - Make sure that the clamps are open ② and frangible pins of the bag(s) are broken ③.
- 2 Solution bag may be empty.
 - Change bag if necessary.
- 3 Possible pressure measurement error.
 - Make sure that the pressure lines and pressure ports are connected, and no fluid reaches the pressure line filter.
 - Replace kit if fluid has reached the pressure line filter.
- 4 Disposable kit may be leaking.
- 5 Manual level regulation can result in low solution pressure value.
 - Make sure not to decrease solution pressure too low with manual level regulation.

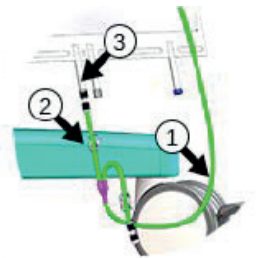

Alarms during therapy (8.3.3)

Blood leak detected in effluent line (8.3.3.13)

A defective haemofilter or plasma filter can leak patient blood to the effluent line. The OMNI® constantly monitors blood leaks to the effluent bag with an optical sensor and automatically stops the fluid side pumps when a blood leak is detected during therapy.

⚠ WARNING!

Risk of blood loss due to defective haemofilter or plasmafilter!

- When a blood leak alarm is indicated, check the patient, the effluent line and the effluent bag for visible signs of blood.
- Do not override the blood leak alarm without making sure that blood is not lost to the effluent line.

1 The haemofilter/plasma filter membrane may be damaged, and blood may be leaking to the effluent line.

Make sure that the effluent line **①** and effluent bag **②** do not contain blood. Check the membrane for blood leaks.

Consider changing the disposable kit.

2 Unusual coloured effluent can cause erroneous blood leak alarms (i.e. bilirubin, rifampicin, pabrinex, propofol, etc.).

Consider overriding the blood leak detection alarm.

3 The blood leak detector **③** may be exposed to bright light.

Shade the front of the machine against any light and reset the alarm or consider overriding the alarm.

4 Air in the effluent line may also lead to false blood leak alarms.

Check the effluent chamber **④**.

If the level in the chamber is too low, override the alarm and remove the air using the level regulation system or manually with a syringe through the sample port **⑤**. Once the level is at 2/3, return to the blood leak detection alarm and press No override.

Things to check in case of a blood leak alarm

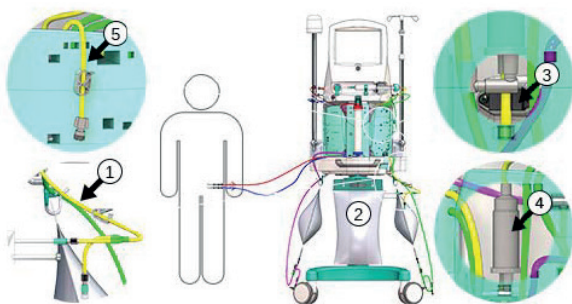

Key

- | | |
|------------------------------|-------------------------------|
| ① Effluent line | ④ Effluent chamber |
| ② Effluent bag | ⑤ Effluent sample port |
| ③ Blood leak detector | |

Tips

You can continue the therapy if the cause of the alarm is determined not to be a true blood leak, in which case free haemoglobin will not be present in the sample.

It is possible to send an effluent sample for analysis to determine if the cause of the alarm is secondary to myoglobin removal.

When increasing the level in the effluent chamber, always do so very slowly to reduce risk of low venous pressure alarm.

Alarms during therapy (8.3.3)

Removing air from venous line (8.3.3.14)

Air in the venous line is a dangerous situation for the patient. The machine constantly monitors the venous line with the venous safety air detector. When air is detected in the venous line:

- The machine stops the blood pump.
- The machine closes the venous clamp.
- The machine generates an alarm and displays the *Air removal from venous line* screen.

In order to remove air from the venous line, the venous pressure has to be reduced. This can be done by the machine or manually.

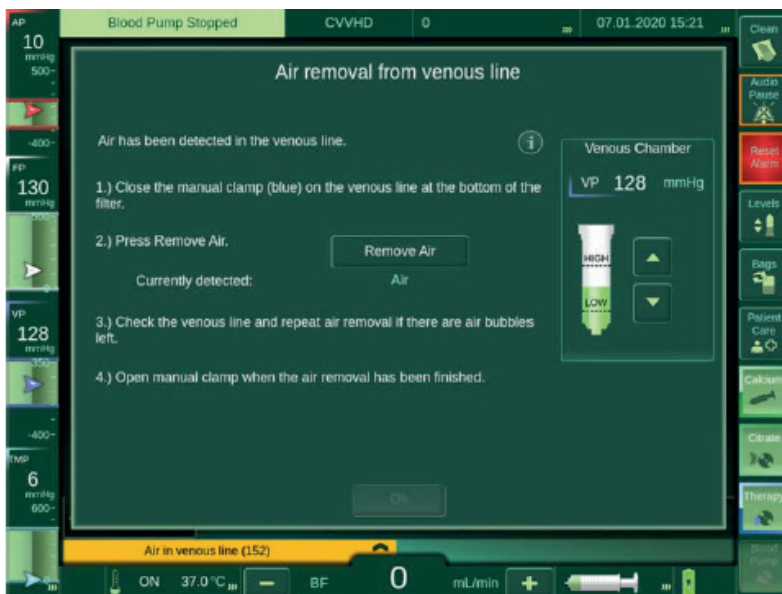

1 Close the manual clamp (blue) on the venous line at the bottom of the filter.

2 Press the Remove Air button.

The machine decreases the pressure in the venous line to -50 mmHg. The machine opens the venous clamp and sucks the air out. The machine closes the venous clamp again.

3 Check the venous line.

4 If there are still air bubbles left, repeat the air removal.

5 When the air is removed, open the manual clamp (blue) below the filter and press the OK button.

Alarms during therapy (8.3.3)

Removing air from calcium line (8.3.3.15)

Air in the calcium line is a dangerous situation for the patient. The machine constantly monitors the calcium line with the calcium safety air detector. When air is detected in the calcium line:

- The machine stops the blood pump.
- The machine closes the venous clamp.
- The machine generates an alarm and displays the *Air was detected by the calcium air detector* screen.

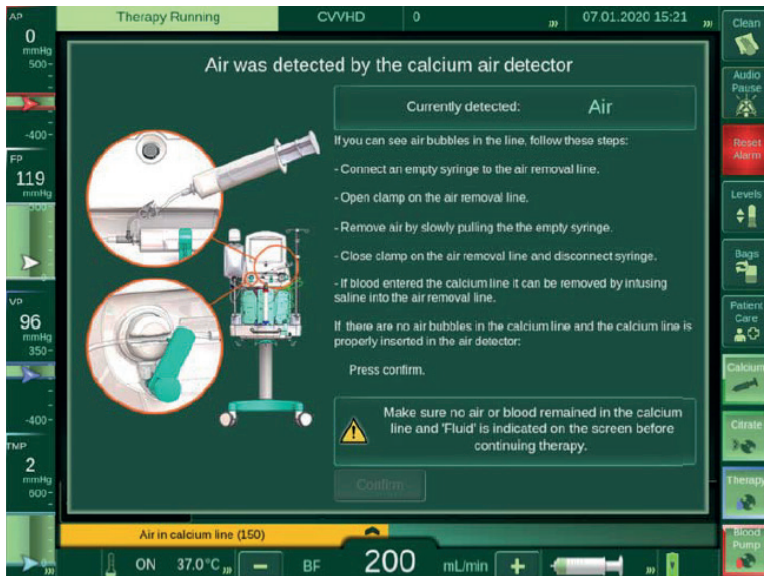

Tip

Do not infuse saline into the calcium line whilst the patient is connected to the venous line, as you can inadvertently bolus calcium or push a clot into the vascular access.

Instead, press the stop button, disconnect the venous line, and flush calcium line into a sterile pack.

- 1 Connect an empty syringe to the air removal line.
- 2 Open clamp on the air removal line.
- 3 Remove air by slowly pulling the empty syringe.
- 4 Make sure no air or blood remained in the calcium line and 'Fluid' is indicated on the screen before continuing therapy.
- 5 Close clamp on the air removal line and disconnect syringe.
- 6 If blood entered the calcium line, it can be removed by infusing saline into the air removal line.
- 7 Make sure there is no blood in the calcium line before continuing therapy.

Alarms during therapy (8.3.3)

Warmer door open (8.4.0)

Close warmer door at the back of the machine to proceed with treatment. Make sure that the latch of the door clicks into locked position.



Do not open warmer door during treatment.

Once the disposable kit has been installed and the warmer bag has been filled with fluid, the warmer door shall not be opened during treatment.

- 1 Press the bags button.
- 2 Unlock the disposable kit from the locks on the fluid side. Do not attempt to pull off the green plate.
- 3 Open the magnetic fluid side door.
- 4 Manually remove the dialysate tube segment from the dialysate pump (green square).
- 5 Close the warmer door (return the fluid from the warmer bag to the dialysate bag).
- 6 Blood leak detected in effluent line alarm may appear, temporarily override it.
- 7 Lock the green plate back onto the OMNI®.
- 8 Manually feed the dialysate line back around the dialysate pump.
- 9 Shut the fluid side door.
- 10 Press Bag Change/Weight Reset and reset all alarms.
- 11 After alarms are resolved, it is possible to select 'No override' for the blood leak detection alarm.

Internal alarms (8.4.0)

Internal alarms such as failed self-tests, communication failures, load cell failures, power relay tests, etc. can often be resolved by rebooting the machine. If it is possible to return the blood and enter temporary patient disconnection, do so before rebooting. Reboot takes approximately three minutes after which there will be the opportunity to continue treatment or start a new treatment.

Manual blood return

Please note that manual blood return is possible using the grey lever on the blood pump, but the venous line will also have to be removed from the venous clamp beforehand.

Additional resources

- More information on **troubleshooting arterial and venous pressures** can be found on page 22
- Scan the QR code to access the online educational resources available on the B. Braun website:
 - Continuous Renal Replacement Therapy (CRRT)
 - Therapeutic Plasma Exchange (TPE)
 - OMNI® User Guide (IFU) SW 1.75
 - OMNI® E-Learning
 - OMNI® Tutorial Videos
 - CVVH with pre- and post-dilution in heparin anticoagulation
 - CVVHD in citrate-calcium anticoagulation
 - Therapy interventions
 - TPE in heparin anticoagulation



Arterial and venous pressure troubleshooting

Arterial pressures

The **arterial** pressure is the pressure required to **PULL** blood from the patient.

Arterial pressures are always **negative**.

Low arterial pressure:

Very negative pressure, meaning it's hard to pull the blood from the patient. Possible causes are listed below:

- Patient position
- Kinks
- Clamps
- Vascular access position
- Clots in the vascular access or arterial line
- Hypotension
- Hypovolemia
- Arterial pressure line may contain blood
- Blood flow rate may be too high
- Patient coughing

High arterial pressure:

Much less negative pressure or positive pressure, meaning it's too easy to pull the blood from the patient. Possible causes are listed below:

- Vascular access in an artery
- Possible disconnection
- Possible pressure measurement error
- Blood flow rate may be too low
- Hypertension
- Hypervolemia

Venous pressures

The **venous** pressure is the pressure required to **PUSH** the blood back to the patient.

Venous pressures are always **positive**.

High venous pressure:

Very high positive pressure, meaning it's hard to push the blood back to the patient. Possible causes are listed below:

- Patient position
- Kinks
- Clamps
- Vascular access position
- Clots in the vascular access or venous line
- Hypertension
- Hypervolemia
- Blood viscosity
- Blood flow rate may be too high
- Patient coughing

Low venous pressure:

Much lower venous pressure (<-10 mmHg), meaning it's too easy to push the blood back to the patient. Possible causes are listed below:

- Possible disconnection
- Possible leak on venous line
- Possible pressure measurement error
- Blood flow rate may be too low
- Hypotension
- Hypovolemia
- Blood viscosity
- Bed too low (gravity)

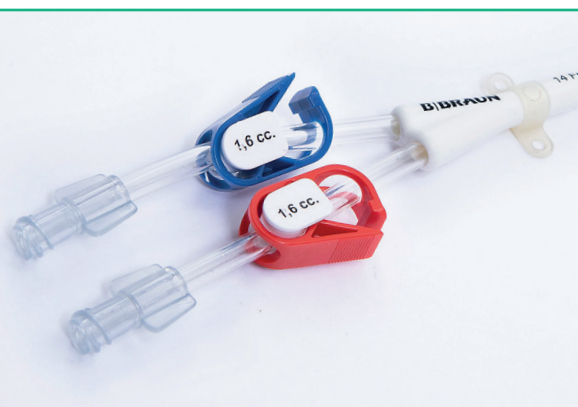

The vast majority of filters fail due to poor vascular access. Always optimise the blood flow to prevent stasis and clot formation in the circuit.

When in doubt, use 'temporary patient disconnection' to return the blood and go into recirculation. This gives you six hours to troubleshoot your access!

