

Veka M



KEY ADVANTAGES

- Up to 4 installation methods
- Tool-free access from the top
- Sturdiness: IP66 + IK10
- Die-cast aluminium (Cu<0.1%)
- Energy Efficient:
GEN1: 155lm /W
GENA: 161 lm/W
- Up to 7 optical distributions
- Smart Ready: Designed to house both indoor and outdoor communications nodes
- Future Proof: Zhaga-compliant
- Life span L90B10 100,000h (Ta) 25°C
- Night Friendly: ULR Arrêté du 27 décembre 2018
- A presence sensor can be incorporated into the luminaire.
- Optional pre- or post-installation shielding for these luminaires
- 5 years guarantee.



Dark-Sky Association certification

≤ 3.000K not available for 4.000K.

Mechanical adjustment: max. + or- 15 degrees to allow leveling in the field.

DESCRIPTION

Veka is the new family of luminaires by Carandini for public street lighting. Its elegant aesthetics, latest generation LED technology and optical distributions make it a top-quality solution for urban streets, main or secondary roads, motorways, dual carriageways and car parks.



STANDARDS / CERTIFICATES

- CE
- RoHS
- UNE-EN 60598-1
- UNE-EN 60598-2-3
- UNE-EN 62471:2009
- UNE-EN 61000-3-2
- UNE-EN 61000-3-3
- UNE-EN 55015
- UNE-EN 61547
- UNE-EN 62031
- UNE-EN 61347-2-13
- UNE-EN 62384
- UNE-EN 13032-4
- UNE-EN ISO 9227 NSS: 2017 (1,000 h)

| | |
|--|--|
| GEN1: 2.322lm - 20.800lm GENA: 3.128lm - 22.833lm | PT: 0.1 m ² SE: 0.1 m ² |
| GEN1: 155lm /W GENA: 161 lm/W Luminaire | -40°C - +50°C |
| 9 Kg | 0.00% - 0.35% FHS/ULR |
| Tool-free access to control gear | |

220 - 240 V / 100 V - 277 V
50-60 Hz
L90B10 100,000 h
Ta 25°C

PHOTOMETRIC DISTRIBUTIONS

7 photometric configurations are available for use in the various environments where this type of luminaire might be installed, meaning it can be adapted to suit all situations:

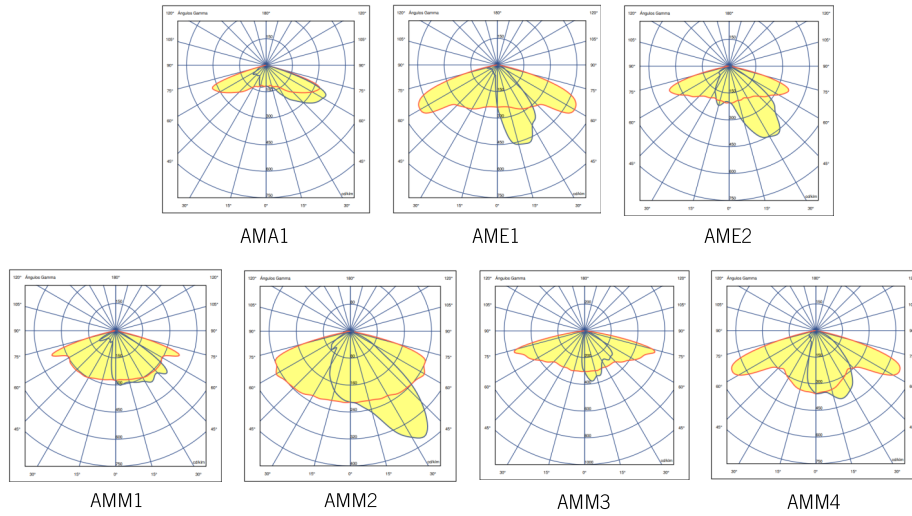

DIMENSIONS

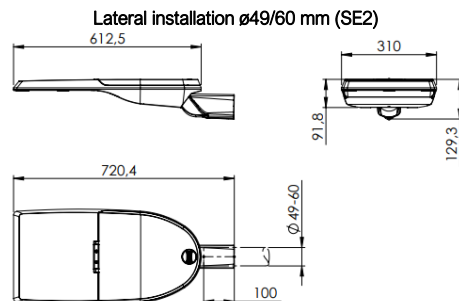
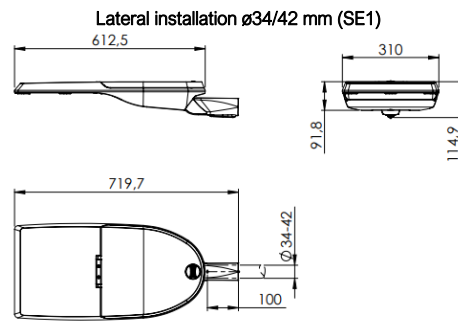
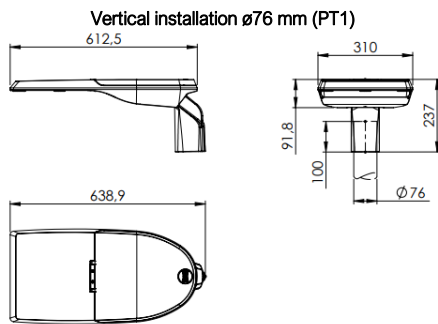

APPLICATIONS

Public streets, main or secondary roads, motorways and dual carriageways, and car parks.



VEKA M CHARACTERISTICS

GENERAL INFORMATION

| | |
|-------------------|--|
| Sustainability | Recyclability: 99,38% % Carbon footprint per use: 0,020461 kg kW/h de CO2 |
| CE mark | Yes |
| ENEC Certificate | Yes |
| RoHS-compliant | Yes |
| Testing standards | LM 79-80 (all measurements at ISO17025 certified laboratory) |

GENERAL CHARACTERISTICS

| | |
|--------------------------------------|--|
| Body and mounting | Pressure die-cast aluminium EN AC-44100 (LM6) with low copper content <0.1%. |
| Light enclosure | 5mm toughened flat glass. |
| Exterior nuts and bolts | Stainless steel (AISI304). |
| General ingress protection | IP66 (EN 60598-1 and EN 60529) |
| Degree of protection against impacts | IK10 (EN 62262) |
| Operating temperature | Ta -40°C to +50°C According to luminaire configuration. |
| Estimated life | L90B10 100.000 h at Ta 25°C. Light maintenance values at TM-21 Socketd on LM- |
| Cables | Class I/II Cable from 5 to 12 metres Cross section: 2x1,5 ; 3x1,5; 4x1,5; 5x1,5; 2x2,5; 3x2,5; |

ELECTRICAL CHARACTERISTICS

| | |
|------------------------|---|
| Electrical class | Class I or Class II |
| Input voltage | 220 V - 240 V / 50 Hz - 60 Hz Optional 100 V- 277 V |
| Power factor | > 0.9 |
| Harmonic distortion | < 10% |
| Overvoltage protection | Overvoltage protection (1.2/50) 10 kV. Maximum current (8/20) 10kA. Maximum voltage (L-N) 320 V. Maximum voltage (L/N-GND) 400 V. Optional overvoltage protection: 20kA, 20kV |

LIGHTING CHARACTERISTICS

| | |
|------------------------------|---|
| Real light package | GEN1: 2.322lm - 20.800lm (21 - 161W) GENA: 3.128lm - 22.833lm (21 - 161W) |
| LED colour temperature | 4,000 K (Neutral White, nw). 3,000 K (Warm White, ww). 2,700 K (Warm White, ww). 2,200 K (Warm White, ww). Amber colour temperature, upon request. |
| Colour rendering index (CRI) | CRI>70. CRI80 upon request. |
| LEDs | Includes 32, 48 and 64 LEDs. |
| ULR/FHS | Between 0.00% and 0.35% |
| Optics | Acrylic PMMA lenses especially designed for LEDs. |
| Photometric configurations | AMA1=> Throw 70° Spread 65° (Type IV) AME1=> Throw 65° Spread 15° (Type I) AME2=> Throw 70° Spread 35° (Type II) AMM1=> Throw 70° Spread 35°/50° (Type III) AMM2=> Throw 60° Spread 35° (Type II) AMM3=> Throw 75° Spread 5°/20° (Type III) AMM4=> Throw 65° Spread 20° (Type II) |
| LED thermal management | Heat dissipation via conduction, radiation and convection Socketd on a design for LED technology. |

FINISHES

PREDEFINED COLOUR OF THE LUMINAIRE

| | |
|----------|---|
| RAL 9006 | Grey polyester powder coat paint RAL 9006 Smooth Gloss (9006B). |
|----------|---|

Corrosion protection

| | |
|---|-----------------------------------|
|  | Marine Finish (1.000h) (Optional) |
|---|-----------------------------------|

VEKA M CHARACTERISTICS

MAINTENANCE AND ASSEMBLY

| | |
|------------------------------|--|
| Installation and maintenance | Tool-free luminaire access system designed by Carandini. Access to the driver from the top. |
| Installation | PT1: Vertical installation \varnothing 76 mm.* SE1: Lateral installation \varnothing 34/42 mm. SE2: Lateral installation \varnothing 49/60mm. * The PT1 fixing shall be supplied horizontally mounted with SE for sustainability. |
| Mechanical adjustment | Vertical and lateral installations offer an inclination angle range of $\pm 10^\circ$ for every 2.5° . |
| Equipped weight | PT1: 9.2 Kg SE1: 8.7 Kg / SE2: 9 Kg |
| Wind Surf. | PT: 0.1 m ² SE: 0.1 m ² |
| Pressure equalisation valve | The luminaire is fitted with a valve that balances the pressure in the luminaire to prevent the build-up of condensation, thereby extending the lifetime of the components. |

MANAGEMENT AND CONTROL

| | |
|-----------------------|---|
| Devices | 1N: LED 1 level RC: Adjustable LED in head RD: Adjustable LED Protocol DALI AF: Adjustable LED Protocol 1-10 V RL: Pulse adjustable LED 2N: Dual level SR: Smart Ready D4i |
| Autonomous regulation | Factory-programmable regulation: 56: 50% from 00:00 to 06:00 66: 60% from 00:00 to 06:00 76: 70% from 00:00 to 06:00 SC: As requested by the client. |
| CLO regulation | Percentage flow during product lifetime: 7: 70% luminous flux during luminaire lifetime. 8: 80% luminous flux during luminaire lifetime. 9: 90% luminous flux during luminaire lifetime. |
| Sockets | 3-U: NEMA 3 pin socket with/without IP66 cover. 5-V: NEMA 5 pin socket with/without IP66 cover. 7-W: NEMA 7 pin socket with/without IP66 cover. X: Upper Zhaga socket with/without IP66 cover. O-Y: Lower Zhaga socket with/without IP66 cover. P-Q: Lower/Upper Zhaga socket with/without IP66 cover. |
| Photocells | 1: Photocell for Nema 3, 5 and 7 pin socket (20 lux) 2: Photocell for larger Zhaga socket (20 lux) 3: Movement sensor for lower Zhaga socket. 4: Photocell for upper Zhaga socket (20 lux) and movement sensor for lower Zhaga socket. |
| Node | ON: Controlux One BS: Controlux Basicrolux One |

ACCESSORIES

Optional pre- or post-installation shielding for these luminaires



VEKA M PHOTOGRAPHS



LOGISTICAL INFORMATION*

VEKA M PT

Box size: 657 x 328 x 280 mm

Box weight: 9.2 kg.

Number of boxes: 18 units

American Socket: 1200 x 800 x 1880 mm

Stack height: 6 levels

Area occupied: 67.3%

Volume used: 62.9%

Total gross weight: 185 kg

VEKA M SE

Box size: 765 x 355 x 170 mm

Box weight: 9.2 kg.

Number of boxes: 27 units

American Socket: 1200 x 800 x 1850 mm

Stack height: 9 levels

Area occupied: 85%

Volume used: 81%

Total gross weight: 268 kg

NOTE: By sustainability reasons PT1 & PT2 fixing accessories will be supplied assembled by side entry (SE)

*If the luminaire includes a cable, please consult dimensions Box

LUMINAIRE ADJUSTMENT

By programming the driver

Programming profile

The driver can be programmed in such a way that, during less busy hours of the night, the luminaire reduces the luminous flux, while remaining in compliance with the required lighting and uniformity levels.

Programming profile 56

Between midnight and 6 am, the brightness of the luminaire is reduced by 50%.

Up to

26%
savings

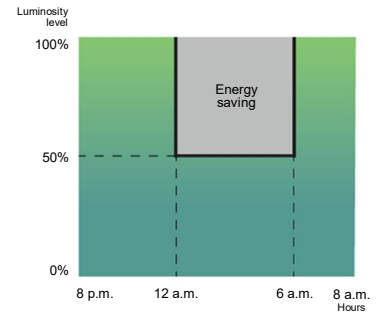

Via CLO function

Taking into account lighting depreciation over the years, the driver is programmed to start at a reduced level and gradually increase power over the lifetime of the luminaire, which saves energy and increases the service life of the system. In addition, the level of illumination of the area in which it is located is always kept constant.

Constant luminous flux 8

Luminaire luminous flux at 80% to maintain light levels throughout its service life.

Up to

10%
savings

and increase in luminaire service life

Luminous flux chart

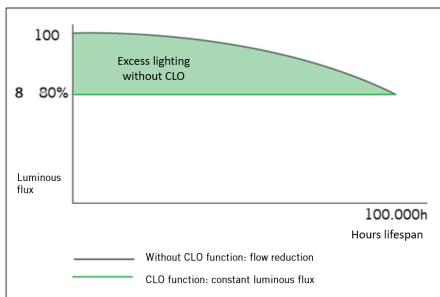

Consumption graph

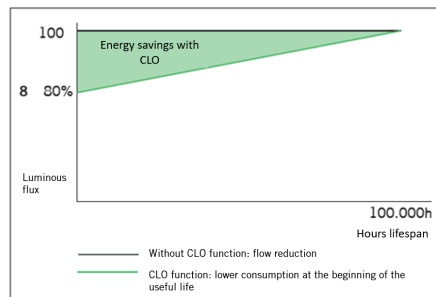

By adding an extra element

Photocell

The photocell allows the luminaire to be switched on or off depending on the intensity of the sunlight it captures.

This is very useful, to avoid having luminaires on at times when there is still enough natural light.

Example with 20 lx photocell:



INNOVATIVE AND UPDATABLE OVER TIME (Zhaga/ ZD4i)

"All luminaires incorporating Nema Sockets or Zhaga Sockets, where the control system is not the responsibility of Carandini, must always incorporate IP 66 covers in order to ensure the correct safety and operation of the product.

The sale of luminaires with Nema or Zhaga Sockets without the IP 66 cover will only be permitted upon receipt of a written assurance from the customer that the control system using NEMA or ZHAGA Nodes will be installed by the customer at the same time as the luminaires".

Zhaga

Zhaga - Future Proof

Zhaga is an industry-wide consortium that aims to standardise specifications for interfaces between LED luminaires and light sources. The aim is to achieve interchangeability between products made by different manufacturers. Zhaga defines test procedures for luminaire and LED light sources so that the luminaire can receive the LED source.



Zhaga D4i - Sensor Ready

The Zhaga consortium joined up with DiiA to create a unique Zhaga-D4i certification that combines Zhaga's Book 18 version 2 outdoor connectivity specifications with DiiA's D4i specifications for intra-luminaire DALI.

BOOKS PER APPLICATION. A COST-EFFECTIVE SOLUTION.

Z H A G A Consortium
Book 1-25
Overview by application

| | Office & Industry | Retail & Hospitality | Outdoor |
|----------------------------------|-------------------|----------------------|-----------|
| Integrated LED light engines | 14, 2,8 | 17, 16 | |
| LED modules (non-integrated) | 7, 21, 14 | 12, 9, 5, 3,10 | 4, 15, 19 |
| Drivers | 13 | LED set 22,23 | 24,25 |
| Sensor and communication modules | | 20 | 18 |

The specifications that mark a component as Zhaga-compliant are contained in a series of books, available only to consortium members, that allow you to design to the marked standard. The benefits for society are evident since, apart from reducing the consumption of materials, it favours the reuse of luminaires, aiming towards a circular economy.

CERTIFICATION PROGRAMME

Zhaga-D4i certification covers all the essential characteristics, including automatic adjustment, digital communication, data reporting and power requirements in any single luminaire, ensuring plug-and-play interoperability for luminaires (drivers) and peripherals, such as connectivity nodes.

STANDARDISATION AS A MEANS TO ACHIEVE SUSTAINABILITY

The **Veka M** luminaire has been designed to function with the latest available market-proven technology Socketd on standards. This also enables it to meet the CARANDINI sustainability requirements and become a product ready for maintenance in the future under better guarantees while respecting the environment and society.

The luminaires marked as Zhaga are a "Future Proof" design, meaning it is Socketd on and designed around standard Zhaga components. These components are mainly the LED modules and the drivers. The electric compartment and dissipation area for LED modules has space and additional mountings to include any driver compliant with Zhaga "Book 13" Socketd on market driver dimensions, or any LED module compliant with Zhaga "Book 15" Socketd on LED controller interface specifications.

This makes it possible to have a sustainable product that can be updated over time.

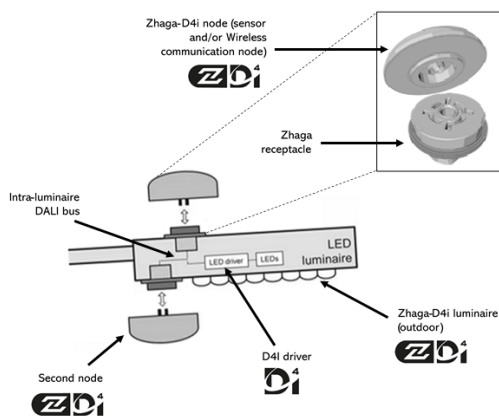

CONNECTIVITY

D4i specifications take the best of the standard DALI2 protocol and adapt it to an interconnected lighting environment, but with certain limitations. Only the control devices installed in the luminaires can be combined with a Zhaga-D4i luminaire. According to the specifications, the control devices are respectively limited to an average power consumption of 2 W and 1 W.

SMART CITY

Luminaires marked ZD4i are a "Smart Ready" design, which means they are designed to house both indoor and outdoor communication nodes through connection sockets compliant with the Zhaga "Book 18" & Zhaga-D4i standard on sensor and communication node interoperability.