

M4 x 0.7 CAGE LOCKING SCREW
2.0mm [5/64in] HEX
2 PLACES, BOTH SIDES

LOCKING SCREW FOR ENGAGEMENT OF FINE ADJUSTMENT MICROMETER
1.5mm [1/16in] HEX
DO NOT OVERTIGHTEN WHEN LOCKING

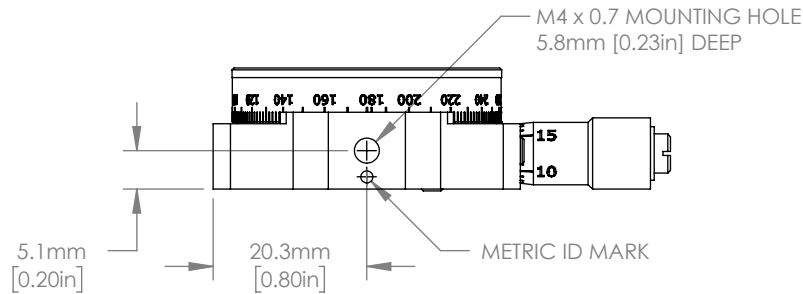
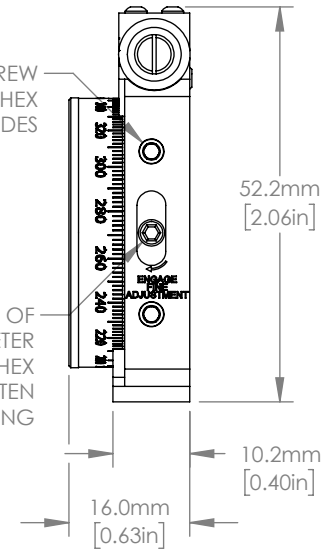

NOTE: OVERTIGHTENING THE FINE ADJUSTMENT LOCK SCREW MAY PREVENT PROPER OPERATION OF FINE ADJUSTMENT FEATURE

FOR INFORMATION ONLY
NOT FOR MANUFACTURING PURPOSES

DRAWING PROJECTION			THORLABS www.thorlabs.com PRECISION METRIC CAGE ROTATION MOUNT	
NAME	DATE			
DRAWN	AK	25/JAN/21	MATERIAL N/A	
APPROVAL	ZM	26/JAN/21		
COPYRIGHT © 2021 BY THORLABS			ITEM #	APPROX WEIGHT
VALUES IN PARENTHESIS ARE CALCULATED AND MAY CONTAIN ROUND OFF ERRORS			CRM1PT/M	0.05 kg
			REV	A