

ACVATIX

Electromotive actuators for valves

SAS..



Actuators with 5.5 mm stroke and 400 N force

- SAS31.. Operating voltage AC 230 V, 3-position control signal
- SAS61.. Operating voltage AC 24 V / DC 24 V
Positioning signal DC 0...10 V / DC 4...20 mA / 0...1000 Ω
- SAS61./MO operating voltage AC 24 V / DC 24 V
RS485 for Modbus RTU communication
- SAS81.. Operating voltage AC/DC 24 V, 3-position control signal
- For direct mounting on valves; no adjustments required
- Manual adjuster, position and status indication (LED)
- Optional function extension with auxiliary switch

Application

To operate Siemens 2-port and 3-port valves:

- Types V..G44.., VVG55.., and VVG549..
- 5.5 mm stroke

Used as control and shutoff valves in heating and ventilation plants.

Together with the ASK30 mounting kit, all former Landis & Gyr valves with 4 mm or 5.5 mm stroke can also be operated: X3i.., VVG45.., VXG45.., VXG46.., VVI51...

Features

Function	Description	Type
3-position control	A 3-position signal controls the actuator via connection terminals Y1 or Y2. The desired position is transmitted to the valve.	SAS31.. SAS81..
Modulating control	The positioning signal range (DC 0...10 V / DC 4...20 mA / 0...1000 Ω) corresponds to the positioning range (closed...open, or 0...100% stroke) in a linear manner.	SAS61..
Positioning signal and characteristic changeover	Setting with DIL switch. Factory setting SAS..: <ul style="list-style-type: none"> • Characteristic curve: log = Equal percentage (switch set to Off) • Positioning signal: DC 0...10 V (switch set to Off) 	
Position feedback U	Signal returned to acquire the position via input.	
Forced control (Z-mode)	Forced control helps override automatic mode and is implemented via higher control.	
Calibration	Carry out during initial commissioning. The actuator drives to the top or bottom end position; the measured values are saved.	SAS61.. SAS61../MO
Valve seat detection	The actuators have power-dependent seat detection. After calibration, the exact valve stroke is stored in the actuator's memory.	
Foreign body detection	After clogging is detected, three attempts are made to get past clogging. If unsuccessful, the actuator continues to follow the positioning signal only within a limited range, and the LED flashes red.	
Modbus RTU (RS-485), not galvanically isolated	Setpoint 0..100% valve position Actual value 0..100% for valve position Override control Open / Close / Min / Max / Stop Setpoint monitoring and backup mode	SAS61../MO

Type summary

Type	Item NO.	Operating voltage	Positioning signal	Positioning time	Spring return		Manual adjustment ¹⁾	Position feedback	Comment		
					funct.	time					
SAS31.00	S55158-A106	AC 230 V	3-pos.	120 s	No	-	Yes	-	2)	4)	
SAS31.03	S55158-A107			30 s							
SAS31.50	S55158-A108			120 s	Yes	<28 s ⁶⁾	No				
SAS31.53	S55158-A109			30 s							<14 s ⁶⁾
SAS61.03	S55158-A100	AC/DC 24 V	DC 0...10 V DC 4...20 mA 0...1000 Ω	30 s	No	-	Yes	DC 0...10 V	2)	5)	
SAS61.03U	S55158-A100-A100								3)		
SAS61.03/MO	S55158-A121								Modbus RTU		2), 7)
SAS61.33	S55158-A101			DC 0...10 V DC 4...20 mA 0...1000 Ω	30 s	Yes	<14 s ⁶⁾	No	DC 0...10 V		2)
SAS61.33U	S55158-A101-A100										3)
SAS61.33/MO	S55158-A122			Modbus RTU	2), 7)						
SAS61.53	S55158-A102			DC 0...10 V DC 4...20 mA 0...1000 Ω	30 s	Yes	<14 s ⁶⁾	No	DC 0...10 V		2)
SAS81.00	S55158-A103	AC/DC 24 V	3-pos.	120 s	No	-	Yes	-	2)		
SAS81.03	S55158-A104			30 s					2)		
SAS81.03U	S55158-A104-A100								3)		
SAS81.33	S55158-A105			Yes	<14 s ⁶⁾	2)					
SAS81.33U	S55158-A105-A100					3)					

¹⁾ Not designed for continuous operation

⁵⁾ Approvals: CE, UL

²⁾ Cable gland: M16, M20 (ISO50262)

⁶⁾ Spring return time at low temperatures slightly longer

³⁾ Cable gland ½" (UL514C)

⁷⁾ Fixed connection cable 5 x 0.75 mm²

⁴⁾ Approbation: CE

Delivery

Actuators, valves, and accessories are supplied in individual packs.

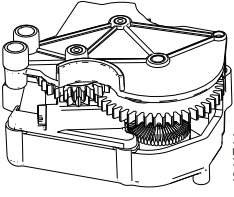
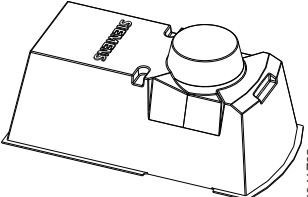
Electrical accessories	Mechanical accessory
<p>Auxiliary switch ASC10.51</p>  <p style="text-align: right; font-size: small;">4041Z14</p>	<p>Weather shield ¹⁾ ASK39.2</p>  <p style="text-align: right; font-size: small;">4041Z25</p>

¹⁾ SAS61../MO is not intended for outdoor use

Ordering (example)

Type	Order number	Designation	Number of pieces
SAS31.00	S55158-A106	Actuator	1
+ auxiliary components such as connections, aux switches, etc.			

Spare parts

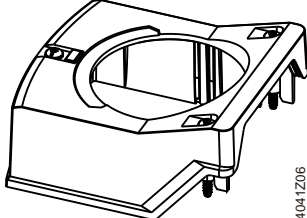
Order number	Description	
S55845-Z180	<p>Type ASQ1: Housing cover with associated screws and light guide as component, without laser labeling</p>  <p style="text-align: right; font-size: small;">4041Z06</p>	

Device combinations

Valves PN16					Actuators SAS..	
VVG44.. (2-port)	VXG44.. (3-port)	DN	G	k _{vs}	Δp _s	Δp _{max}
Medium: 1...120 °C			[inch]	[M ³ /h]	[kPa]	[kPa]
VVG44.15-.. ¹⁾	VXG44.15-.. ¹⁾	15	G 1 B	0.25 / 0.4 / 0.63	1600	400
VVG44.15-.. ¹⁾	VXG44.15-.. ¹⁾	15	G 1 B	1 / 1.6	725	400
VVG44.15-.. ¹⁾	VXG44.15-.. ¹⁾	15	G 1 B	2.5 / 4	400	400
VVG44.20-6.3	VXG44.20-6.3	20	G 1 ¼ B	6.3	750	400
VVG44.25-10	VXG44.25-10	25	G 1 ½ B	10	400	400
VVG44.32-16	VXG44.32-16	32	G 2 B	16	250	250
VVG44.40-25	VXG44.40-25	40	G 2 ¼ B	25	125	125

¹⁾ = use k_{vs} value

Valves PN25					Actuators SAS.. ¹⁾	
VVG549. (2-port)	DN	G	k _{vs}	Δp _s	Δp _{max}	
Medium: 1...130 °C		[inch]	[m ³ /h]	[kPa]	[kPa]	
VVG549.15-0.25	15	G ¾ B	0.25	2500	1200	
VVG549.15-0.4	15	G ¾ B	0.4	2500	1200	
VVG549.15-0.63	15	G ¾ B	0.63	2500	1200	
VVG549.15-1	15	G ¾ B	1.0	1500	1200	
VVG549.15-1.6	15	G ¾ B	1.6	1500	1200	
VVG549.15-2.5	15	G ¾ B	2.5	1500	1200	
Pressure compensated						
VVG549.20-4K	20	G 1 B	4.0	1600	1200	
VVG549.25-6.3K	25	G 1 ¼ B	6.3	1600	1200	

¹⁾ SAS.. combined with VVG549: Change DIL switch setting to linear (factory setting = log).
SAS../MO: Change additional Modbus register 263 to "0 = linear"

Valves PN25				Actuators SAS..	
VVG55.. (2-port) ¹⁾	DN	G	k _{vs}	Δp _s	Δp _{max}
Medium: 1...130 °C		[inch]	[m ³ /h]	[kPa]	[kPa]
VVG55.15-.. ²⁾	15	G ¾ B	0.25 / 0.4 / 0.63	2500	1200
VVG55.15-.. ²⁾	15	G ¾ B	1 / 1.6 / 2.5	2000	1200
VVG55.20-4	20	G 1 B	4	1000	1000
VVG55.25-6.3	25	G 1 ¼ B	6.3	800	800

¹⁾ VVG55 is replaced by VVG549 from Jan 1, 2017.

²⁾ = use k_{vs} value

Product documentation

Title	Contents	Document ID
Actuators SAS.., SAT.. for valves	Basic documentation: Comprehensive information on actuators SAS..	CE1P4041
Electromotive actuators for valves SAS..	Datasheet: Product description SAS..	CE1N4581
Electromotive actuators for valves SA.., Modbus RTU	Datasheet: Modbus communication profiles	A6V101037195
Mounting instructions S..6../MO and G..161../MO	Mounting instructions: Mounting and installation instructions	A5W00027551
Valve actuator DIL switch characteristic overview	Commissioning / configuration: Depictions, description of actuator and valve characteristics by DIL switch setting	A6V12050595

Related documents such as the environmental declarations, declarations of conformity, etc., can be downloaded from the following Internet address:

www.siemens.com/bt/download

Safety

 **CAUTION**
**National safety regulations**

Failure to comply with national safety regulations may result in personal injury and property damage.

- Observe national provisions and comply with the appropriate safety regulations.

Engineering

SAS31.. and SAS81..

3-position actuators must have their own specific controller, see "Connection diagrams".

SAS61..

Up to 10 actuators can drive in parallel on a controller output with a rating of 1 mA.
Modulating actuators have an input impedance of 100 kΩ.

SAS61../MO

The Modbus converter is dimensioned for analog control at 0..10 V.

Note: Keep the analog signal setting on the actuator as is (switch 1 to "Off"); adjustment not possible.

The actuators are parameterized at the factory to an equal-percentage characteristic; this corresponds to their use with valves VVG/VXG44.

When using SAS61.03/MO with valve series VVG549, the following must be set:

- *Actuator:* DIL switch (internal actuator characteristic changeover) to linear (switch 2 to "ON").
- *Modbus register:* Set reg. 263 to "0 = linear".

Installation

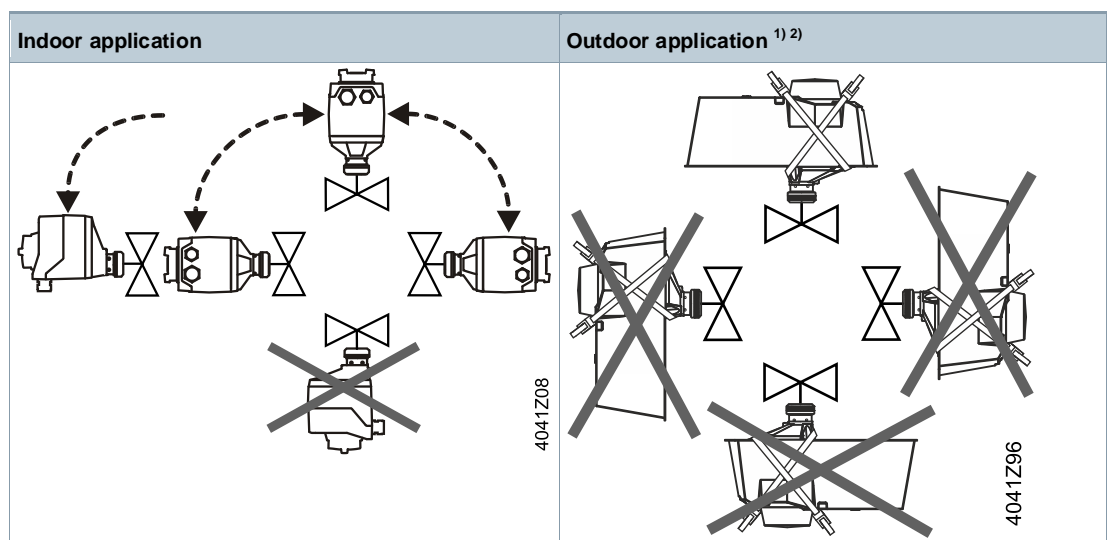
Mounting positions

1) Requires weather shield ASK39.2 Housing protection class remains IP54.

2) SAS61../MO is not intended for outdoor use.

Maintenance

The SAS.. actuators are maintenance-free.

Actuator installation:

- Do not touch valve coupling if components (valve/piping) are hot
- If necessary, disconnect electrical connections from the terminals

Correctly fit the actuator to the valve before recommissioning.

Disposal

⚠ WARNING



Tensioned spring return

Opening the actuator housing can trigger the fully tensioned spring return resulting in flying parts and possible injury.

- Do not open the actuator housing.



This symbol or any other national label indicate that the product, its packaging, and, where applicable, any batteries may not be disposed of as domestic waste. Delete all personal data and dispose of the item(s) at separate collection and recycling facilities in accordance with local and national legislation.

For additional details, refer to [Siemens information on disposal](#).

Warranty

The application-specific technical data is guaranteed only in combination with the Siemens products listed in the 'Device combinations' section. If third-party products are used, any guarantee provided by Siemens will be invalidated.

Technical data

Power supply		
Operating voltage	SAS31..	AC 230 V ± 15 %
	SAS61..	AC 24 V ± 20% / DC 24 V +20% / -15% or AC 24 V class 2 (US)
	SAS81..	AC/DC 24 V ± 20 % or AC 24 V class 2 (US)
Frequency		45...65 Hz
External supply line fusing (EU)		Fuse slow 6 A...10 A or fuse switch max. 13 A, release characteristic B,C,D as per EN 60898 power source with current limitation of max. 10 A
Typical switch-on current ¹⁾ (3-Position actuators without constant power)	SAS31..	2.3A
	SAS81..	2.8A

Functional data		
Positioning time for nominal stroke	SAS..0	120 s
	SAS..3 / SAS..3U	30 s
Positioning force		400 N
Nominal stroke		5.5 mm
Permissible media temperature with valve		1...130 °C

Signal inputs		
Y1 / Y2	SAS31..., SAS81..	3-pos.
	SAS31.. Voltage	AC 230 V ± 15 %
	SAS81.. Voltage	AC 24 V ± 20% / DC 24 V + 20% / - 15%
Positioning signal "Y"	SAS61..	DC 0...10 V / DC 4...20 mA / 0...1000 Ω
	SAS61.. (DC 0...10 V) current draw	≤ 0.1 mA
	Input impedance	≥100 kΩ
	SAS61.. (DC 4...20 mA) current draw	DC 4...20 mA ± 1%
	Input impedance	≤ 500 Ω

Power consumption at 50 Hz					
Type	Item NO.	Operating [W]	Operating [VA]	Standby [W]	Standby [VA]
SAS31.00	S55158-A106	1.2	2.4	1.0	2.0
SAS31.03	S55158-A107	1.5	3.1	1.0	2.1
SAS31.50	S55158-A108	1.5	3.3	1.0	2.3
SAS31.53	S55158-A109	2.3	4.7	1.3	2.9
SAS61.03	S55158-A100	2.3	5.7	1.8	4.6
SAS61.03U	S55158-A100-A100	2.3	5.7	1.8	4.6
SAS61.03/MO	S55158-A121	2.8	6.4	2.3	6.0
SAS61.33	S55158-A101	3.0	7.2	2.2	5.5
SAS61.33U	S55158-A101-A100	3.0	7.2	2.2	5.5
SAS61.33/MO	S55158-A122	3.5	7.9	2.7	6.9
SAS61.53	S55158-A102	3.1	7.4	2.2	5.6
SAS81.00	S55158-A103	1.3	2.6	1.1	2.3
SAS81.03	S55158-A104	1.6	3.2	1.2	2.4
SAS81.03U	S55158-A104-A100	1.6	3.2	1.2	2.4
SAS81.33	S55158-A105	2.4	4.6	1.5	2.9
SAS81.33U	S55158-A105-A100	2.4	4.6	1.5	2.9

Communication SAS61../MO		
Communication protocol	Modbus RTU	RS-485, not galvanically isolated
	Number of nodes	Max. 32
	Address range	1...245 / 255 Factory setting: 255
	Transmission formats	1-8-E-1 / 1-8-O-1 / 1-8-N-1 / 1-8-N-2 Factory setting: 1-8-E-1
	Baud rates (kBaud)	Auto / 9.6 / 19.2 / 38.4 / 57.6 / 76.8 / 115.2 Factory setting: Auto
	Bus termination	120 Ω electronically switchable Factory setting: Off

Parallel connection	
SAS61..	≤ 10 (depending on controller output)

Forced control		
Z positioning signal	SAS61..	R = 0...1000 Ω, G, G0
	R = 0...1000 Ω	Stroke proportional to R
	Z connected to G	Max. stroke 100%
	Z connected to G0	Min. stroke 0%
	Voltage	Max. AC 24 V ±20% / Max. DC 24 V +20 % / -15%
	Current draw	≤ 0.1 mA

Position feedback		
U	Voltage range SAS61..	DC 0...10 V
	Load impedance	> 10 kΩ resistive
	Load	Max. 1 mA

Connection cable		
Wire cross-sectional areas		0.75...1.5 mm ² , AWG 20...16 ²⁾
Cable entries	SAS.. (EU)	1 entry Ø 16.4 mm (for M16) 1 entry Ø 20.5 mm (for M20) Thread length max. 9 mm
	SAS..U (US)	2 entries dia. 21.5 mm for ½" tube connection
	SAS61../MO	Fixed connection cable 0.9m Number of cores 5 x 0.75 mm ²

Protection class		
Protection degree of housing	See Installation [▶ 7]	IP 54 as per EN 60529
Insulation class as per EN 60730	Actuators SAS31.. AC 230 V	II
	Actuators SAS61.. AC / DC 24 V	III
	Actuators SAS81.. AC / DC 24 V	III

Environmental conditions		
Operation per IEC 60721-3-3	Climatic conditions	Class 3K5
	Mounting location	Indoors, outdoors ²⁾
	Temperature, general	-5...55 °C
	Humidity (non-condensing)	5...95 % r. h.
Transport per IEC 60721-3-2	Climatic conditions	Class 2K3
	Temperature	-25...70 °C
	Humidity	< 95 % r. h.
Storage per IEC 60721-3-1	Temperature	-15...55 °C
	Humidity	5...95 % r. h.

Standards		
Product standard		EN60730-x
Electromagnetic compatibility (field of use)		For residential, commercial and industrial environment
EU conformity (CE)		See EU declaration of conformity CE1T4581xx ⁴⁾ (8000073402)
UK conformity (UKCA)		See UK declaration of conformity A5W00185820A-001 ⁴⁾
RCM conformity		See RCM declaration of conformity CE1T4581en_C1 ⁴⁾ (8000069574)
UL, cUL	AC / DC 24 V	UL 873 http://ul.com/database file number E35198
EAC compliance		Eurasien compliance for all SAS variants

Environmental compatibility
The product environmental declaration A5W02128675A ⁴⁾ contains data on environmentally compatible product design and assessments (RoHS compliance, material composition, packaging, environmental benefit, and disposal).

Dimensions / weight
See Dimensions [▶ 18]

Accessories ⁵⁾		
Auxiliary switch ASC10.51	Switching capacity	AC 24...230 V, 6 (2) A, potential free
	External fusing of supply line	See "Power supply"
	US installation, UL & cUL	AC 24 V class 2, 5 A general purpose

1) Switching time for RMS value of the sine wave at nominal voltage

2) AWG = American wire gauge.

The planner/installer is responsible for matching wire cross sections and fuses. Standard regarding protective measures – Note protection for overcurrent:

IEC 60364-4-43:2008 or German adoption HD 60364-4-43:2010.

3) For outdoor operation, always use weather shield ASK39.2, housing protection class IP 54 remains as is. SAS61../MO is not intended for outdoor use.

4) Documents can be downloaded at <http://siemens.com/bt/download>.

5)

By UL-approved component 

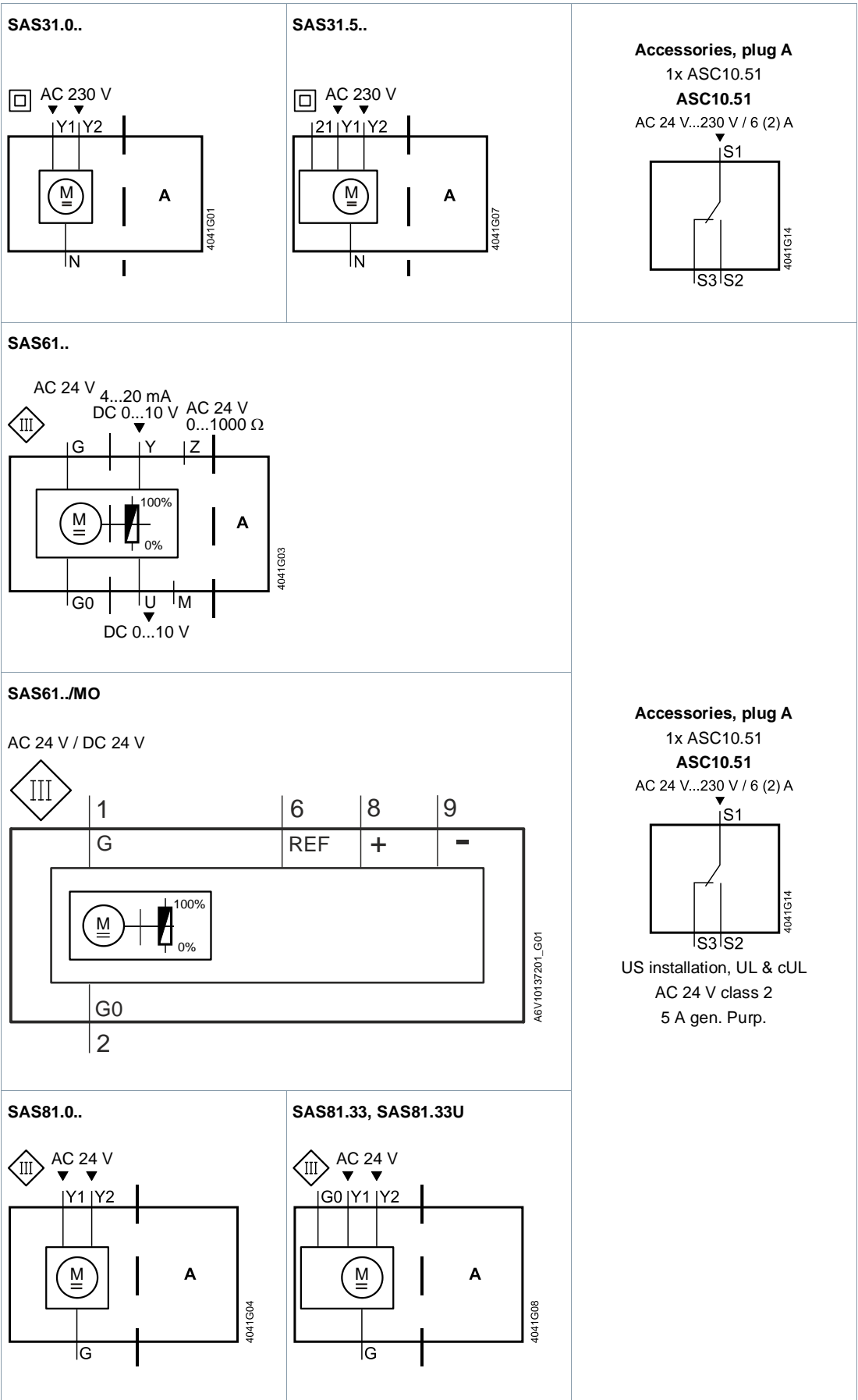

Connection terminals

SAS31.0..	AC 230 V, 3-position
<div style="display: flex; flex-direction: column; align-items: center;"> <div style="margin-bottom: 2px;">4040Z17</div> <div style="margin-bottom: 2px;">N</div> <div style="margin-bottom: 2px;">Y1</div> <div style="margin-bottom: 2px;">Y2</div> </div>	<p>System neutral (SN)</p> <p>Positioning signal (actuator's stem extends)</p> <p>Positioning signal (actuator's stem retracts)</p>

SAS31.5..	AC 230 V, 3-position
<div style="display: flex; flex-direction: column; align-items: center;"> <div style="margin-bottom: 2px;">4041Z82</div> <div style="margin-bottom: 2px;">N</div> <div style="margin-bottom: 2px;">Y1</div> <div style="margin-bottom: 2px;">Y2</div> <div style="margin-bottom: 2px;">21</div> </div>	<p>System neutral (SN)</p> <p>Positioning signal (actuator's stem extends)</p> <p>Positioning signal (actuator's stem retracts)</p> <p>Spring return</p>

SAS61..	AC/DC 24 V, DC 0...10 V / 4...20 mA / 0...1000 Ω
<div style="display: flex; flex-direction: column; align-items: center;"> <div style="margin-bottom: 2px;">4040Z16</div> <div style="margin-bottom: 2px;">G0</div> <div style="margin-bottom: 2px;">G</div> <div style="margin-bottom: 2px;">Y</div> <div style="margin-bottom: 2px;">M</div> <div style="margin-bottom: 2px;">U</div> <div style="margin-bottom: 2px;">Z</div> </div>	<p>System neutral (SN)</p> <p>System potential (SP)</p> <p>Positioning signal for DC 0...10 V / 4...20 mA</p> <p>Measuring neutral</p> <p>Position feedback DC 0...10 V</p> <p>Positioning signal forced control AC/DC ≤ 24 V, 0...1000 Ω</p>

SAS61../MO	AC/DC 24 V, Modbus RTU connection cable	
<div style="display: flex; flex-direction: column; align-items: center;"> <div style="margin-bottom: 2px;">4040Z59</div> <div style="margin-bottom: 2px;">G0</div> <div style="margin-bottom: 2px;">G</div> <div style="margin-bottom: 2px;">REF</div> <div style="margin-bottom: 2px;">+</div> <div style="margin-bottom: 2px;">-</div> </div>	<p>System neutral (SN)</p> <p>System potential (SP) AC 24 V ~ / DC 24 V =</p> <p>Reference line (Modbus RTU)</p> <p>Bus + (Modbus RTU)</p> <p>Bus - (Modbus RTU)</p>	<p>black</p> <p>red</p> <p>purple</p> <p>gray</p> <p>pink</p>

SAS81.0..	AC/DC 24 V, 3-position
<div style="display: flex; flex-direction: column; align-items: center;"> <div style="margin-bottom: 2px;">4040Z19</div> <div style="margin-bottom: 2px;">G</div> <div style="margin-bottom: 2px;">Y1</div> <div style="margin-bottom: 2px;">Y2</div> </div>	<p>System potential (SP)</p> <p>Positioning signal (actuator's stem extends)</p> <p>Positioning signal (actuator's stem retracts)</p>

SAS81.33U	AC/DC 24 V, 3-position
<div style="display: flex; flex-direction: column; align-items: center;"> <div style="margin-bottom: 2px;">4041Z80</div> <div style="margin-bottom: 2px;">G</div> <div style="margin-bottom: 2px;">Y1</div> <div style="margin-bottom: 2px;">Y2</div> <div style="margin-bottom: 2px;">G0</div> </div>	<p>System potential (SP)</p> <p>Positioning signal (actuator's stem extends)</p> <p>Positioning signal (actuator's stem retracts)</p> <p>System neutral (SN)</p>

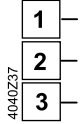
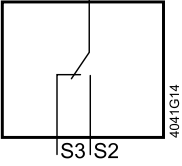
Electrical accessories		
ASC10.51	Auxiliary switch, adjustable switching positions, AC 24...230 V	
	System potential (SP) Closes (actuator stem extends) Opens (actuator stem extends)	AC 24 V...230 V / 6 (2) A 

Internal diagrams

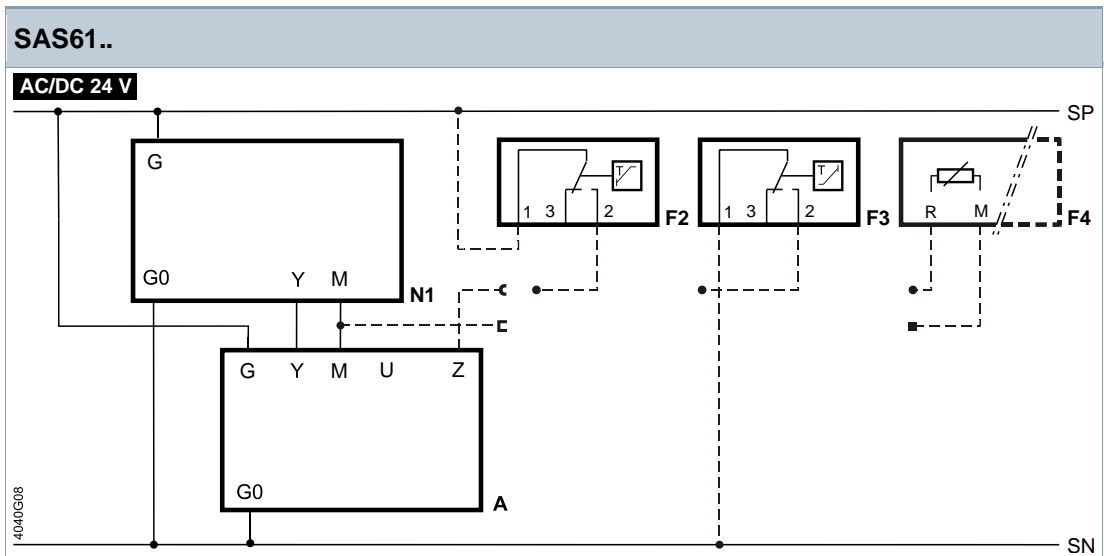
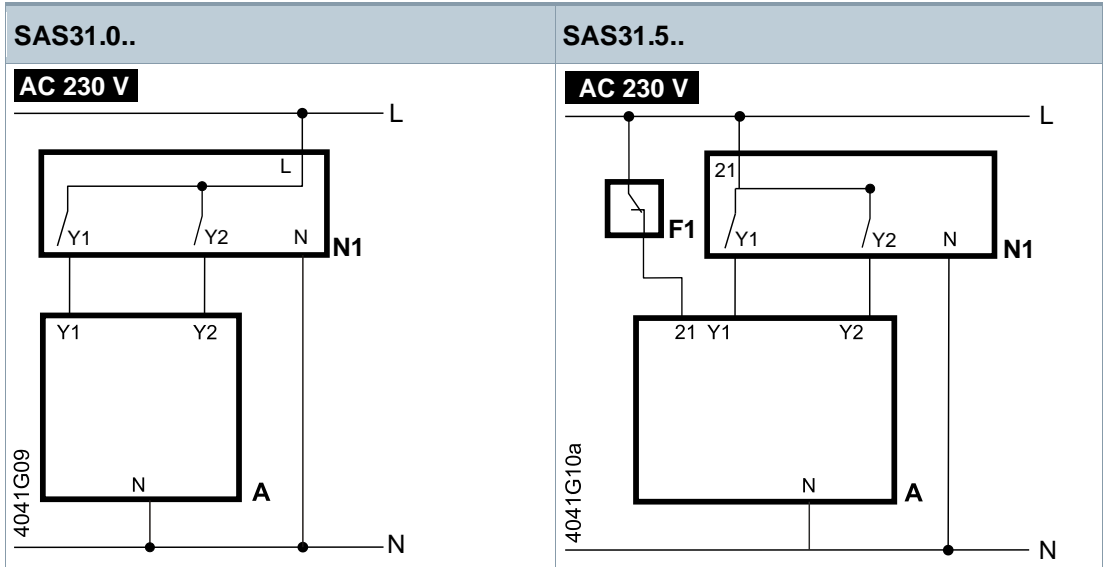

SAS61.33 / SAS61.33U / SAS61.53

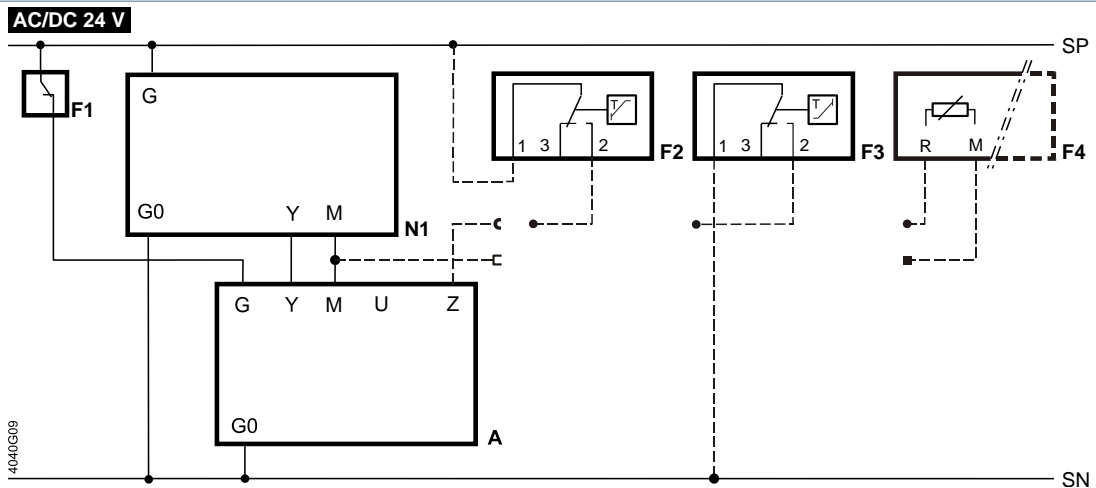

SAS61.03/MO

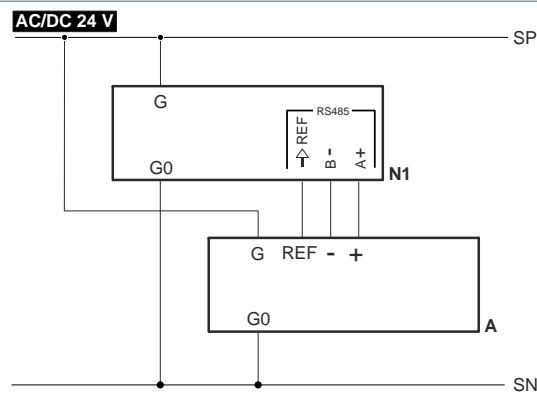

SAS61.33/MO ¹⁾

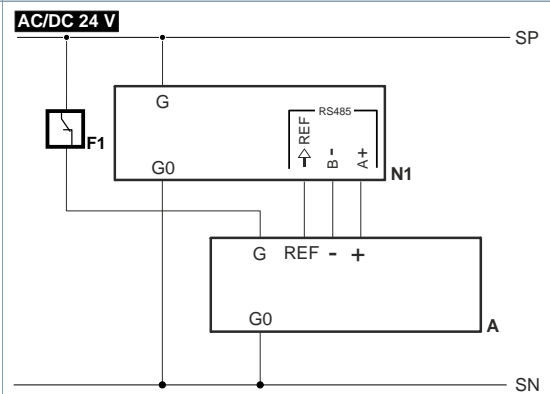

¹⁾ The actuator can no longer be addressed via the bus once the limit thermostat is triggered.

SAS81.0..

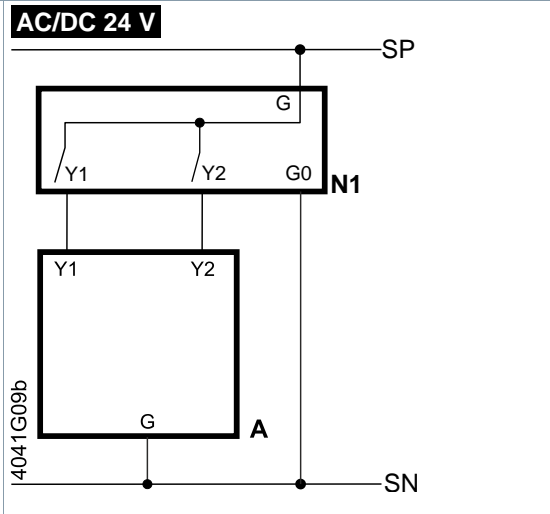
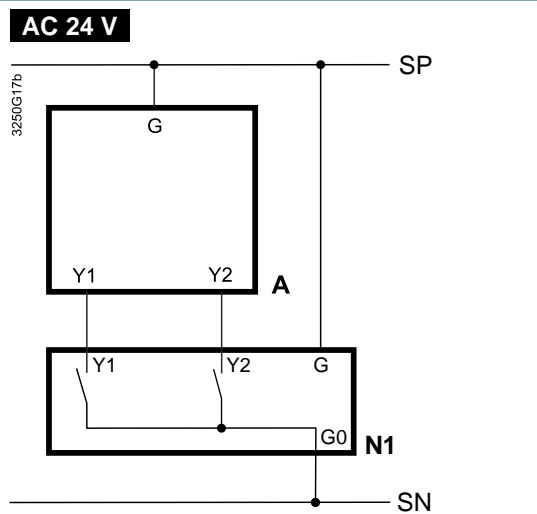

SAS81.33, SAS81.33U

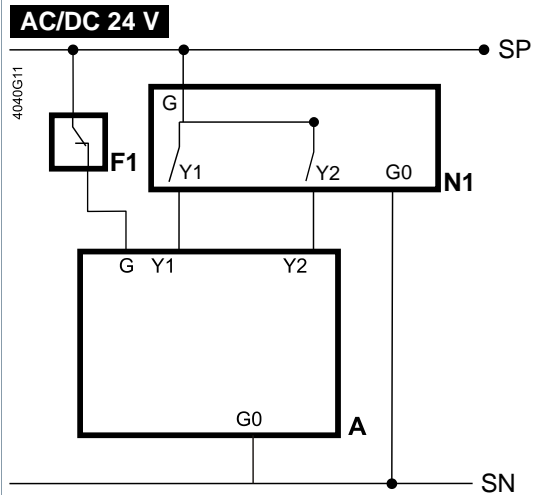

A	Actuator	REF	Reference line (Modbus RTU)
F1	Temperature limiter	SN	System neutral
F2	Frost protection thermostat; terminals: 1 – 2 Frost hazard / sensor is Off (thermostat closes upon frost) 1 – 3 normal operation	SP	System potential AC/DC 24 V
F3	Thermal reset limit thermostat	U	Position feedback
F4	Frost protection monitor with 0...1000 Ω signal output, does NOT support QAF21.. or QAF61..	Y	Positioning signal
G	System potential (SP)	Y1, Y2	Positioning signals
G0	System neutral (SN)	Z	Positioning signal forced control
L	Phase	21	Spring return
M	Measuring neutral	+	Bus + (Modbus RTU)
N	Neutral	-	Bus - (Modbus RTU)
N1	Controller		

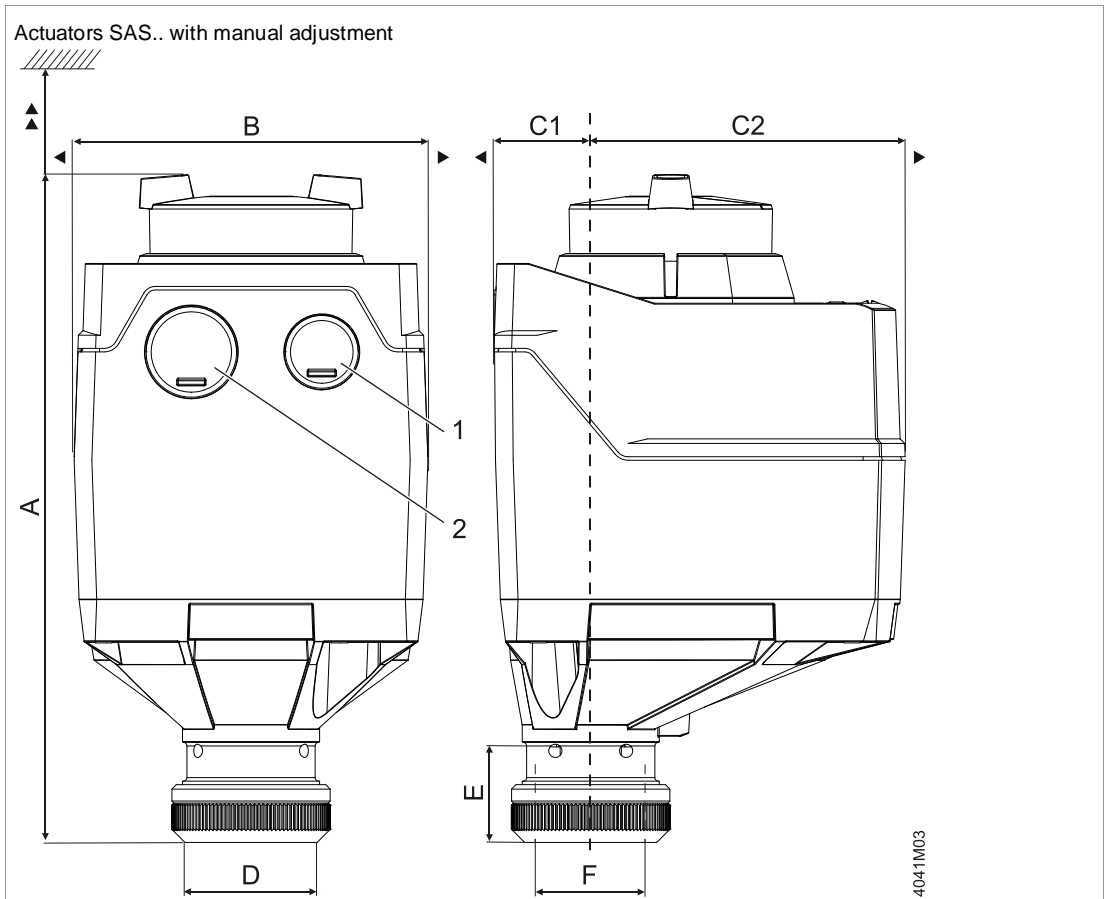

Type	A [mm]	B [mm]	C [mm]	C1 [mm]	C2 [mm]	D [mm]	E [mm]	F [inch]	▶ [mm]	▶▶ [mm]	kg [kg]	1	2
SAS..	151	80	93	21.9	71.1	29.9	21.8	G ¾	100	200	0.40	M16 1) 3)	M20 1) 3)
SAS../MO 2)											0.55		
With ASK39.2	155	126	248	99	149						0.55		

- 1) SAS..U: ½" (dia. 21.5 mm)
- 2) Device has a fixed connection cable – left cable entry occupied
- 3) Tread length max. 9 mm

Actuators SAS.. without manual adjustment

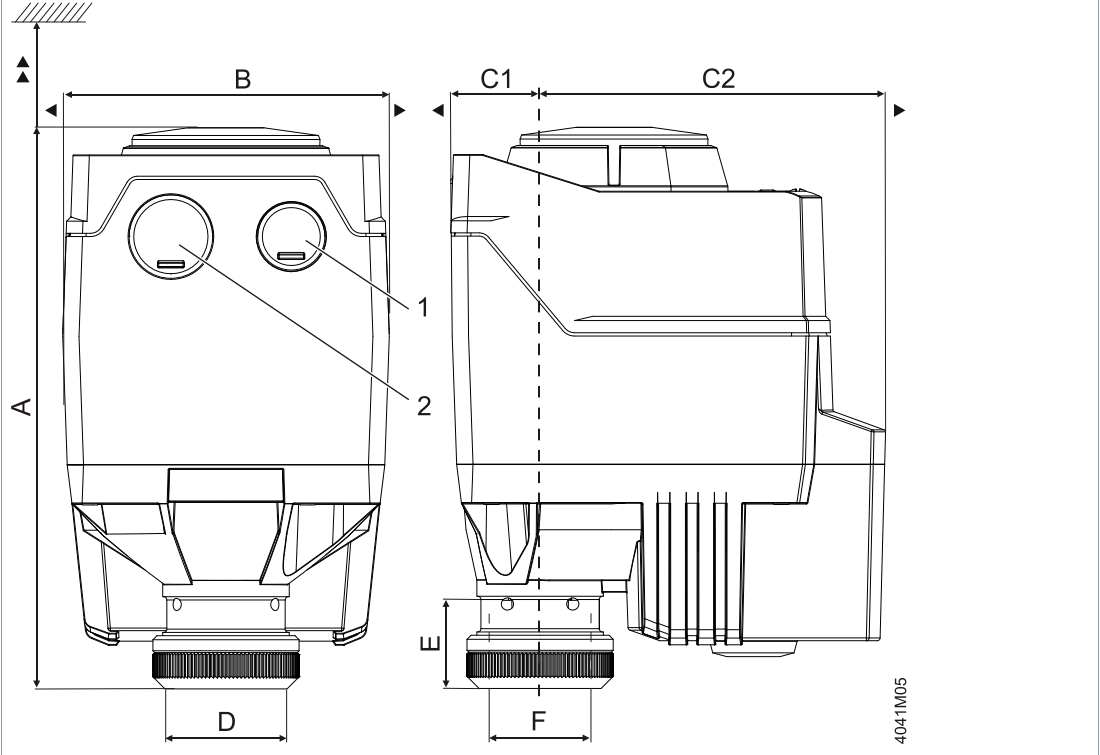

Type	A [mm]	B [mm]	C [mm]	C1 [mm]	C2 [mm]	D [mm]	E [mm]	F [inch]	▶ [mm]	▶▶ [mm]	kg [kg]	1	2
SAS..	137.6 ¹⁾ 151 ²⁾	80	106.5	21.9	84.6						0.68		
With ASK39.2	155	126	248	99	149	29.9	21.8	G 3/4	100	200	0.83	M16 ³⁾	M20 ³⁾

1) Black cover

2) Blue handwheel

3) Tread length max. 9 mm

External Modbus converter

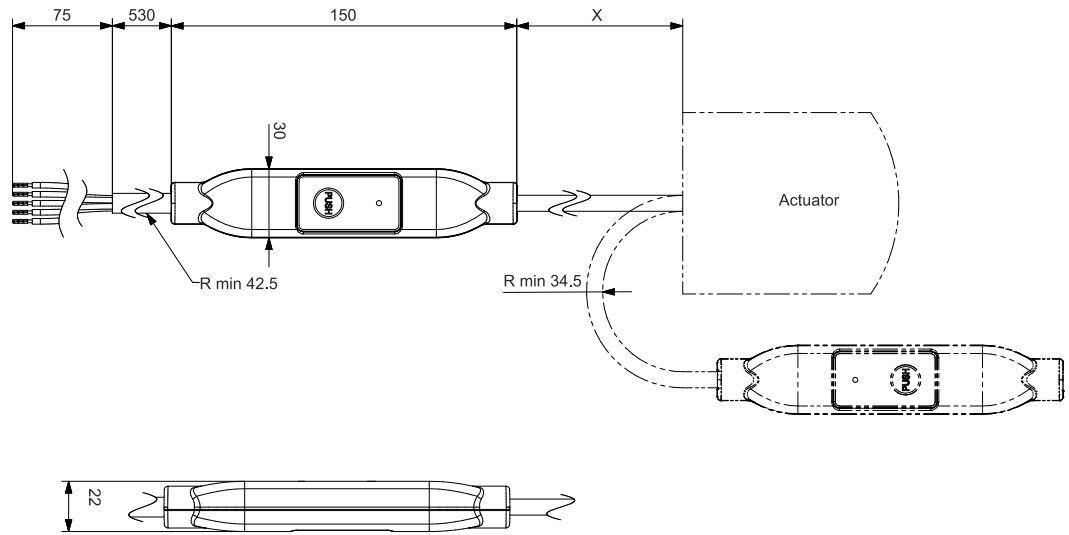

Type	X [mm]	kg [kg]
SAS../M O	250	0.15 ¹⁾

¹⁾ Included in total weight

Dimensions in mm

Revision numbers

Type	Valid from rev. no.
SAS31.00	..B
SAS31.03	..B
SAS31.50	..B
SAS31.53	..B
SAS61.03	..B
SAS61.03U	..B
SAS61.03/MO	..B
SAS61.33	..B
SAS61.33U	..B
SAS61.33/MO	..A
SAS61.53	..B
SAS81.00	..B
SAS81.03	..B
SAS81.03U	..B
SAS81.33	..B
SAS81.33U	..B

Issued by
Siemens Switzerland Ltd
Smart Infrastructure
Global Headquarters
Theilerstrasse 1a
CH-6300 Zug
+41 58 724 2424
www.siemens.com/buildingtechnologies

© Siemens 2015
Technical specifications and availability subject to change without notice.

Document ID CE1N4581en
Edition 2024-08-27